

AU8809037

ANSTO/E660

ANSTO/E660



**AUSTRALIAN NUCLEAR SCIENCE  
AND TECHNOLOGY ORGANISATION**

**LUCAS HEIGHTS RESEARCH LABORATORIES**

**A QUADRUPOLE MASS SPECTROMETER SYSTEM  
FOR NUCLEAR SAFEGUARDS APPLICATIONS**

by

**P.J. EVANS**

**DECEMBER 1987**

**ISSN 1030-7745  
ISBN 0 642 59881 9**

AUSTRALIAN NUCLEAR SCIENCE  
AND TECHNOLOGY ORGANISATION  
LUCAS HEIGHTS RESEARCH LABORATORIES

**A QUADRUPOLE MASS SPECTROMETER SYSTEM  
FOR NUCLEAR SAFEGUARDS APPLICATIONS**

by

P.J. EVANS

**ABSTRACT**

An on-line enrichment monitor for nuclear safeguards-related surveillance of a pilot-scale gas centrifuge plant is described. This monitor utilises a quadrupole mass spectrometer to measure the isotopic composition of  $UF_6$  in the feed and product gas streams. Details of the design and construction are given, and several difficulties are identified and discussed. Finally, the performance of this system is illustrated with typical results.

ISSN 1030-7745

ISBN 0 642 59881 9

The following descriptors have been selected from the INIS Thesaurus to describe the subject content of this report for information retrieval purposes. For further details please refer to IAEA-INIS-12 (INIS: Manual for Indexing) and IAEA-INIS-13 (INIS: Thesaurus) published in Vienna by the International Atomic Energy Agency.

MASS SPECTROMETERS; GAS CENTRIFUGES; ISOTOPE SEPARATION; INSPECTION; ON-LINE MEASUREMENT SYSTEMS; PILOT PLANTS; SAFEGUARDS; URANIUM HEXAFLUORIDE

#### EDITORIAL NOTE

The Australian Nuclear Science and Technology Organisation replaced the Australian Atomic Energy Commission on 27 April 1987. Reports issued after April 1987 have the prefix ANSTO with no change of the symbol (E, M, S or C) or numbering sequence.

## CONTENTS

1. INTRODUCTION	1	
2. DESIGN CONSIDERATIONS	2	
3. DESCRIPTION OF THE SYSTEM	2	
3.1 Pumping Systems	2	
3.2 Gas Inlet Manifold	3	
3.3 Liquid N <sub>2</sub> Filling System	3	
4. OPERATION OF SYSTEM	4	
5. RESULTS	7	
6. CONCLUSIONS	8	
7. ACKNOWLEDGEMENTS	8	
8. REFERENCES	8	
Figure 1	Block diagram of the system	11
Figure 2	Quadrupole mass analyser and vacuum chamber	11
Figure 3	Gas inlet manifold	12
Figure 4	Top view of the system	12
Figure 5	Side view of the system	13
Figure 6	Ion source and molecular beam inlet	13
Figure 7	Liquid nitrogen filling system	14
Figure 8	Photograph of AAEC enrichment monitor	14
Figure 9	Measurement scheme for the determination of uranium isotope ratios	15
Figure 10	Record of product stream enrichment measurements for a 60-hour period	15

## 1. INTRODUCTION

One feature of the gas centrifuge plant surveillance package proposed by the Australian Atomic Energy Commission (AAEC)\* and accepted by the Australian Safeguards Office (ASO) was the installation of an on-line uranium enrichment monitor [Evans *et al.* 1986, Mercer 1987]. Such a device was considered to be an important component of this package since it provided an immediate and direct measure of the plant's performance. For this reason, careful consideration was given to a number of available monitoring techniques before a final selection was made.

Initial attention focussed on a gas phase enrichment monitor previously developed by the AAEC [Boldeman and Broe 1982]. This monitor, which measures the gamma-ray emission, was designed for off-line measurements and has been used in IAEA-sponsored trials at gas centrifuge enrichment facilities. It was thought that, after appropriate modification, it might be suitable for on-line surveillance measurements. With this end in view, the AAEC monitor was connected to a single gas centrifuge unit and the  $^{235}\text{U}$  enrichment level in the product stream was measured in a series of experiments [Carter and Van Der Valk 1983]. These experiments revealed significant problems in adapting this prototype device as a workable on-line monitor. Of particular note were problems associated with the required sample size, typically several grams of uranium hexafluoride ( $\text{UF}_6$ ), disposal of sample on completion of a measurement and the need to calibrate the detector periodically against a known reference standard. As a consequence of these problems, other techniques for measuring the  $^{235}\text{U}/^{238}\text{U}$  ratio in  $\text{UF}_6$  were examined with reference to the requirements of an unattended surveillance unit.

Quadrupole mass spectrometry has been utilised for the isotopic analysis of  $\text{UF}_6$  gas in a number of studies. Early reports on the use of this technique were largely negative owing to inadequate sensitivity and the low signal-to-noise ratios of analysers available at that time [Jones 1972, 1975]. Subsequently, a quadrupole mass spectrometer (QMS) system, which overcame earlier problems, was developed by Balzers Aktiengesellschaft of Liechtenstein [Rettinghaus 1978]. It was claimed that this system was capable of making single  $^{235}\text{U}/^{238}\text{U}$  ratio measurements with a relative standard deviation of  $1 \times 10^{-3}$  or better. This high accuracy was achieved during computer-controlled operation, without which a somewhat lower accuracy was obtained, and also by calibrating to a reference standard. Without calibration, it was claimed that the isotopic ratio of a sample was reproduced to within one per cent of its true value. Other notable features of this system are its low gas consumption rate of  $1.5 \times 10^{-3} \text{ g h}^{-1}$  and its maintenance-free operation time of at least 1000 hours.

Various operational or performance aspects of the Balzers system were further elaborated in subsequent publications by Rettinghaus and co-workers [Huber *et al.* 1978, Egli *et al.* 1978]. The success of Balzers in this field led to the commercialisation of the system which is now marketed for isotopic and impurity analysis of  $\text{UF}_6$  gas.

The Balzers QMS system has already been used in at least one study with nuclear safeguards implications. Researchers at the Comitato Nazionale per L'Energia Nucleare's research centre at Ispra, Italy incorporated this system into a mobile laboratory which, after transportation to an enrichment facility, would be used for isotopic analysis of uranium-containing samples [Guzzi and Federico 1983]. In addition, Kusahara and Rodrigues [1978, 1980] reported on the use of a QMS isotope analysis system, citing nuclear materials safeguards as a reason for their work. Unfortunately, many technical details of their system were not presented, so the origin of its major components is not known. The brief description of the system provided in the references suggests that it is similar to the Balzers system. Finally, the development of a QMS system for  $\text{UF}_6$  analysis by Nagatoro *et al.* [1979, 1980] is also worth noting.

The use of emission-interferospectrometry for uranium isotope analysis of gaseous  $\text{UF}_6$  was described by Sonobe *et al.* [1976]. However, no further reference to this technique was found and its suitability for routine analysis is not known.

Of the aforementioned methods, mass spectrometry, and quadrupole mass spectrometry in particular, appeared to be the best analytical technique for the present study. Therefore, it was proposed that the on-

---

\* Now the Australian Nuclear Science and Technology Organisation (ANSTO)

line enrichment monitor to be developed by the AAEC should utilise a QMS; this proposal was accepted by the ASO and its implementation is the subject of this report.

## 2. DESIGN CONSIDERATIONS

The requirement that an on-line enrichment monitor for nuclear surveillance be capable of unattended operation (*i.e.* limited inspector access) for extended periods (typically three months or longer) imposes certain constraints on the design of the system. Of particular importance are the following:

- All components should have long-term operational reliability and require a minimum of maintenance.
- Sampling should cause negligible perturbation to the gas line being monitored.
- Facility should be made for either the disposal of samples extracted for analysis or their storage for duration of the project.
- The selected analytical technique should be amenable to fully automatic operation and computer control.
- The system should be suitable for analysis of reactive process gases such as  $UF_6$  and keep any attendant memory effects to a minimum.

Obviously, these constraints are fairly restrictive and preclude many measurement techniques. In selecting a quadrupole mass spectrometer as the basis for the AAEC system, it was believed that these constraints would be largely satisfied. It will become apparent from the ensuing discussion that several compromises had to be made.

Finally, two restrictions not listed above but which were peculiar to local circumstances were time and a fixed budget [Mercer 1987]. By Ministerial decision, operation of the uranium gas centrifuge plant at the Lucas Heights Research Laboratories (LHRL) ceased on February 28, 1986. However, work continued on checking the reliability of the surveillance project. Sufficient funds were available only for the purchase of several key items (*i.e.* the QMS and main vacuum chamber). The other major components were acquired from existing stocks. This meant that less than optimum equipment was used in several instances. The shortage of funds also restricted the testing and comparison of alternative items in cases where more than one type was possible. For example, it was not possible to assess the relative merits of diffusion, ion and cryogenic pumps for this application.

Use of the Balzers QMS system for  $UF_6$  isotope analysis is well documented in both published research papers and supporting technical literature. For this reason, the QMS, molecular beam inlet and main vacuum chamber were purchased from that company.

## 3. DESCRIPTION OF THE SYSTEM

A schematic representation of the AAEC enrichment monitor is given in **figure 1**. **Figure 2** shows a detailed view of the quadrupole mass analyser and main vacuum chamber with a required liquid  $N_2$  cooled baffle. A scaled layout of the gas-handling manifold complete with connections to the feed and product lines is depicted in **figure 3**. Top and side views of the system are shown in **figures 4** and **5**, respectively. The mounting of the molecular beam inlet on the ion source of the QMS is illustrated in **figure 6**. **Figure 7**, describes the liquid nitrogen supply system. Finally, a photograph of the enrichment monitor in position adjacent to the gas centrifuge plant is presented in **figure 8**. The computer used for system control does not appear in this view as it was located in a separate room. Although these figures are largely self-explanatory, several features are discussed below.

### 3.1 Pumping Systems

The Balzers pumping unit (PM 100 A), connected to the QMS chamber (**figure 1**), is a fully integrated, automatic system which incorporates a number of interlocks for protection against various fault conditions. Its control console was modified at LHRL to include an interface for transmitting the high vacuum status of the main chamber to the QMS computer. If the pressure in this chamber exceeded a pre-set maximum value ( $10^{-4}$  Pa), the QMS was turned off until the system recovered.

Unfortunately, a system with similar protection features was not available for the gas inlet manifold, so instead a semi-automatic pumping unit was used. The latter, based on a design developed some years ago by AAEC staff, has proved reliable in a number of applications. This system has a manually operated plate valve at the diffusion pump inlet, so it is not possible to isolate the manifold if a fault occurs.

However, it was necessary to protect the QMS system against a high pressure condition in the manifold. This is achieved by means of a vacuum gauge installed between the diffusion pump inlet and the liquid N<sub>2</sub> trap (figure 5). The output of this gauge is referenced to an upper pressure set-point such that if the latter is exceeded, an alarm condition is transmitted via an interface to the QMS computer.

### 3.2 Gas Inlet Manifold

The inlet manifold depicted in figure 3 was employed in the present study. It is simpler than the one developed by Balzers which is also capable of analysing off-line (batch) samples with pressures above the maximum recommended for on-line measurements (5 Torr). The latter was not necessary for an on-line monitor, therefore, it was not included in the design adopted.

The following items were used to fabricate the inlet manifold:

- Air-operated bellows valves (Nupro SS-4BK-1C).
- Bellows metering (variable leak) valve (Nupro SS-4BMG).
- Toggle-operated bellows valve (Nupro SS-4BKT).
- Stainless steel tubing (type 321), 6.4 mm o.d. x 1 mm i.d.

These components were constructed from materials suitable for use with UF<sub>6</sub> gas. In addition, it was expected that they would offer long-term reliability. Subsequent operating experience has shown the latter to be the case.

The tee-pieces inserted in the tubes connecting feed and product lines to the manifold (figure 3) were a later modification of the original arrangement. Their inclusion permitted test measurements on standard samples of known enrichment without disturbing the feed and product line connections.

As with the Balzers inlet system, short lengths of tubing were used in the manifold so that the hold-up of sample gas was kept to a minimum. For the same reason, it was originally intended to use fine bore stainless steel tube between valves 1 and 2 (figure 3) and the gas lines being sampled, a distance of ~ 300 mm. However, insufficient sample then flowed into the manifold at the prevailing line pressures, so this approach had to be abandoned. As an alternative, 4.8 mm i.d. copper tubing was used and this yielded an adequate flow of gas. A consequence of increasing the internal diameter was that it created a comparatively large gas reservoir in the sections of tube between the feed and product lines and valves 1 and 2 of the manifold (figure 3). Material contained in this volume may not be effectively mixed with the main gas flow (except as a result of sampling), therefore, isotope ratios determined shortly after a change in feed or product gas composition might differ from the correct values. Had time permitted, the inlet manifold shown in figure 3 would have been redesigned so that the distances between the two gas lines and valves 1 and 2 were significantly reduced. As it was, this less than optimum arrangement had to be tolerated for the duration of the project.

A manually-operated, variable leak valve (Nupro SS-4BMG) was included in the inlet system to control the flow of gas to the ion source. For much of the present study, gas flow control was not required, so this valve was usually set at large openings. Recent technical literature (Balzers Product Information, BG 800 16 RE 8002) states that sample flow can be adjusted by means of a servo-operated, variable leak valve. Although automatic operation of this valve undoubtedly provides greater operational flexibility, its inclusion in an unattended monitoring system would have required a more complex and more time-consuming control sequence for sample analysis.

### 3.3 Liquid N<sub>2</sub> Filling System

The pumping system contains three liquid nitrogen (LN<sub>2</sub>) cooled baffles (figure 1). During unattended operation of the enrichment monitor, these baffles have to be automatically replenished with coolant. To satisfy this latter requirement, several difficulties had to be overcome, the most notable of which were the following:

- The three liquid N<sub>2</sub> traps had relatively small coolant volumes and, for this reason, were not particularly suited to automatic filling. It would appear from the literature, that automatic operation of the Balzers' multicoolant baffle (BFA 100 M) is not a recommended option since the necessary components are not supplied.
- An in-house liquid nitrogen supply, located conveniently near the monitor, was not available for the present project.
- Budgetary constraints precluded the purchase of any major items of cryogenic equipment, although provision was made for the purchase of several small components.

For unattended operation of a monitoring system that requires liquid N<sub>2</sub> coolant, it is necessary to have access to an essentially inexhaustible supply. This requirement can be largely satisfied by tapping directly into a liquid N<sub>2</sub> distribution system supplied by a large holding tank which is periodically refilled without emptying. Since this type of facility was not available, an alternative approach was adopted. It entailed the use of two 50 L stainless steel Dewar flasks (figure 8). An operator was required to refill one Dewar every 45 hours which was the maximum supply time of the unit replenishing two traps. The other Dewar, which only refilled the QMS trap, had a depletion time of approximately 65 hours.

If the two-trap Dewar had been dedicated solely to the manifold trap, the interval between Dewar refills could have been extended. This would have meant that the multicoolant baffle (BFA 100 M) operated as a water-cooled unit. This mode of operation would probably have been adequate because the QMS chamber already contained one liquid N<sub>2</sub> cooled baffle. However, cooling the BFA 100 M with liquid nitrogen is advantageous in that it provides an independent back-up baffle in the main vacuum system. This additional protection was a desirable feature for unattended operation and, therefore, was employed in the project.

Obviously, the use of Dewars represents a compromise to the goal of long-term unattended operation, so further consideration of this aspect is needed. Such consideration will have to take into account the types of liquid N<sub>2</sub> facilities available in enrichment plants where a QMS based monitor might be located. A self-contained cryogenic refrigeration system may provide an alternative means of cooling the baffles but the feasibility of this approach was not investigated.

An automatic liquid N<sub>2</sub> level controller, developed at Lucas Heights by Dowson [1985], was utilised for the project. The control circuit for supplying a single trap was triplicated and combined into an integrated package. Signals from low- and high-level sensors located in the traps served as inputs to the control circuit. These initiated the opening and closing of solenoid valves (ASCO B263 209 LT) located in the liquid N<sub>2</sub> supply lines (figure 7). The two 50 L Dewars were fitted with heads suitable for pressurised operation with cylinders of dry nitrogen serving as the pressure source. Gauge pressures (*i.e.* above atmospheric) in the range 40-60 kPa were sufficient for successful operation of the system.

In early tests, two centrifugal pumps (BOC type CSMPB-MS 25, 12 VDC) were used for transferring liquid N<sub>2</sub> from Dewar to the trap. By this means, it was hoped to avoid the use of pressurised gas. However, the centrifugal pumps were susceptible to malfunctions and their slow pumping speed resulted in a relatively large loss of coolant through evaporation. Therefore, they were discarded in favour of the pressurised system which proved to be very reliable.

Each liquid N<sub>2</sub> trap was fitted with a feed tube assembly which consisted of an inlet tube and two level sensors. Light emitting diodes (miniature green type) encapsulated in Araldite epoxy were used as sensors. These were secured into high- and low-level positions which had been found, in preliminary tests, to produce an acceptable liquid N<sub>2</sub> filling cycle. Nylon tubing was used for the coolant transfer lines between Dewars and traps.

A computer interface was incorporated into the liquid N<sub>2</sub> control unit for transmitting to the QMS computer, information on coolant levels and the presence of mains power. A continuous low-level signal from any trap, or a power failure, resulted in the QMS being turned off.

#### 4. OPERATION OF SYSTEM

No problems were encountered during initial vacuum trials on the system. With liquid N<sub>2</sub> cooling of the baffles, a pressure of 10<sup>-5</sup> Pa was readily attained in the QMS chamber after a suitable pump-down period. As was expected, this pressure was not affected by the introduction of condensable sample gases such as

UF<sub>6</sub>. The gas inlet manifold was leak-tested with the QMS and found to be leak free. Throughout the test period, the two pumping systems performed reliably and without failure.

Several minor failures were encountered with both the liquid N<sub>2</sub> level controller and the control unit for manifold valves. In the former instance, some care had to be exercised when pressurising the liquid N<sub>2</sub> Dewars with nitrogen to ensure that the gauge pressure was above 40 kPa. Failure to set a pressure in the range 40-60 kPa could lead to filling problems, especially with the two-trap Dewar. On occasions, this Dewar had to fill the two traps simultaneously, so a minimum pressure (*i.e.* 40 kPa) was required to complete the operation in an acceptable period.

The upper limit of 60 kPa was fixed such that a reasonable margin existed between it and the settings on the pressure relief valves fitted to the Dewar head assemblies. Inadvertent pressurisation of the Dewars above their pre-set relief pressure would result in a continual loss of nitrogen, leading to a comparatively rapid emptying of the cylinder. If this occurred during unattended operation, the supply of liquid N<sub>2</sub> to the traps might be interrupted until the empty cylinder was replaced.

The control unit which switched the solenoid valves supplying pressurised air to the manifold's pneumatic valves ceased functioning on two separate occasions. In both instances, one or more of the four solid-state relays in this unit had failed. They were subsequently replaced by electro-mechanical relays which provided trouble-free operation.

With one exception, the QMS performed satisfactorily throughout the project. The exception was the failure of a +5 V/-5 V converter in the line transceiver (LT 511); once this component was replaced the LT 511 functioned without further problems.

The QMS was initially tested with perfluoromethylcyclohexane (C<sub>7</sub>F<sub>14</sub> - sometimes referred to as PP2). The molecular weight (MW) of this compound is 350 amu; for this reason, it has been used in gas centrifuge studies as a convenient analogue for UF<sub>6</sub> (MW = 352 amu). Unlike UF<sub>6</sub>, PP2 is a relatively unreactive substance which means that an extended interruption to the liquid N<sub>2</sub> supply with a consequent loss of cryogenic cooling of the baffles would cause no problem of the type expected with the uranium compound. Therefore, it was possible to conduct reliability and optimisation tests on the liquid N<sub>2</sub> level controller in conjunction with quadrupole mass spectrometric analysis of PP2.

A previous mass spectrometric study of PP2 [James and Carter 1962] reported a peak at 331 amu due to the C<sub>7</sub>F<sub>13</sub><sup>+</sup> ion, a region of interest to us. In addition to the 331 amu peak, we also observed a peak at 332 amu with an intensity of ~ 7 per cent of the former. This smaller peak is probably due to the <sup>12</sup>C<sub>6</sub><sup>13</sup>CF<sub>13</sub><sup>+</sup> isotopic ion. As these two peaks are in the same mass spectral region as the two most abundant, positive, isotopic ions of UF<sub>6</sub>, namely <sup>235</sup>UF<sub>5</sub><sup>+</sup> (330 amu) and <sup>238</sup>UF<sub>5</sub><sup>+</sup> (333 amu), PP2 was used to simulate the UF<sub>6</sub> case in preliminary work.

The first experiments on PP2 were performed with the QMS operated manually by means of the console controls. A measurement sequence similar to that planned for automatic operation was followed and the peak heights at 331 and 332 amu were determined for a range of initial conditions. These data were then used to calculate the ratio (332 peak height)/(331 peak height), which in all cases was found to be 7.3 per cent. Subsequently, some of the early work on computer control of the QMS was carried out with PP2 as the test gas.

Work on PP2 was followed by an extensive series of experiments on UF<sub>6</sub>. During these experiments, a measurement procedure which fulfilled our particular requirements was devised and this formed the basis for the computer program which controlled system operation. The main steps of this procedure are as follows:

- (i) Close valves to manifold pumping system (each numbered 4 in figure 3) and open valve 1 or 2 simultaneously with valve 3. This sets up the flow of sample gas to the QMS.
- (ii) Wait 30 seconds for gas flow to stabilise. The optimum time was determined in a test performed under typical operating conditions.
- (iii) Switch the QMS mass setting to ~ 329 amu and electrometer current to the 10<sup>-11</sup> A range. Wait 20 seconds for the baseline to settle at a constant value.
- (iv) Scan over the <sup>235</sup>UF<sub>5</sub><sup>+</sup> peak at 330 amu and find the mass value at which the peak maximum occurs.

- (v) Set the mass to the value found in step (iv) and record the detector signal for a pre-set number of readings (typically 50).
- (vi) Alter the mass setting to 327 amu and record the background signal applicable to the 330 amu peak.
- (vii) Switch the QMS mass setting to ~ 332 amu and electrometer current to the  $10^{-9}$  A range.
- (viii) Scan over the  $^{238}\text{UF}_5^+$  peak at 333 amu and find the mass value at which the peak maximum occurs.
- (ix) Set the mass to the value found in step (viii) above and record the detector signal for a pre-set number of readings (typically 50).
- (x) Alter the mass setting to 336 amu and record the background signal applicable to the 333 amu peak.
- (xi) The signals at 330 and 333 amu are used, after correcting for background contributions, to calculate the percentage enrichment,  $^{235}\text{I} \times 100 / (^{235}\text{I} + ^{238}\text{I})$ . In this expression, I refers to the corrected signal intensity and the superscript denotes the relevant isotopic species.
- (xii) In this study, a complete measurement cycle consisted of five consecutive determinations of percentage enrichment. The mean of these measurements, together with the standard deviation, was ultimately transmitted to ASO via the telephone link. Steps (iii) to (xi) were repeated four more times to obtain the required number of data points.
- (xiii) Close valve 1 or 2 (figure 3) and valve 3. Open valve 4 and evacuate the manifold. For automatic operation, the computer program imposed a two-minute delay before the next sample cycle could be initiated. This was found to be adequate for pumping out the previous sample from the manifold.

Omitted from the above procedure is any mention of automatic change to the electrometer current range. A method for doing this was incorporated in the QMS computer program and is described in detail elsewhere [Rutherford 1987b]. It was a necessary addition to the present monitoring system because of large variations in the enrichment levels and changes in the line pressures. Therefore, following either steps (iv) or (viii), a range change will occur if the signal intensity falls outside pre-set limits. By using this approach, the QMS is set on the most suitable ranges for the sample undergoing analysis.

A typical mass spectrum obtained using the above procedure is shown in figure 9. The numbers on this figure correspond to steps in the measurement scheme. The material in this case was natural  $\text{UF}_6$ .

The measurement scheme described above was one of several examined during initial testing of the system. It was adopted because it was in use when operational problems with the QMS were resolved. A lack of time prevented re-examination of the other schemes, including the one used by Huber *et al.* [1978], on an optimised system in order to compare them with the one adopted. However, it seems likely that any one of a number of different measurement schemes would have worked equally well.

The QMS settings used for  $\text{UF}_6$  measurement on the AAEC's enrichment monitor are given in table 1. They differ from those suggested by Balzers (values in parentheses in table 1) for analysis of  $\text{UF}_6$  on a type QMG 511 quadrupole mass spectrometer. However, the accuracy achieved with our settings was comparable to that reported by Balzers [Huber *et al.* 1978]. Despite comparable accuracy, the choice of settings influences the mass spectral peak shapes. With our settings, triangular peaks were obtained; in contrast, Balzers' recommended settings yielded flat-topped, trapezoidal peaks.

TABLE 1  
VALUES OF QMS PARAMETERS

Ion source settings	V0 - 29.6 V	( - )
	V1 - 79 V	( 90 V)
	V2 - 24.4 V	( 24.4 V)
	V3 - 14.8 V	( 15.4 V)
	V4 - 85 V	(147 V)
	V5 - 208 V	(212 V)
	V6 - 180 V	( 66 V)
	V7 - 79 V	( 90 V)
Resolution		58 (38)
Emission current		1.0 mA
Scan speed	1 s/mass unit	) Used for scanning the
Filter	0.03 s	) 330 and 333 peaks

The cross-beam ion source on the QMS was equipped with two rhenium filaments. By means of a switch on the control console, it was possible to select each filament separately or both simultaneously via a series connection. In the latter configuration, a broken filament was automatically by-passed and the other continued to function normally. However, in the computer-controlled mode, the option of operating the filaments individually could not be accessed on the system supplied by Balzers. Thus, simultaneous operation of the two filaments was used for all the work reported here. This approach is inferior to one in which a single filament is used, the second being switched on in the event of a failure. Sequential use of the filaments has the potential to yield a longer, continuous period of operation. A lack of time prevented examination of the possibility of modifying the QMS to function in this way.

Computer control and programming for the QMS system are discussed in detail by Rutherford [1987a,b].

## 5. RESULTS

The accuracy of the AAEC enrichment monitor was determined in a set of off-line experiments. By utilising the sample cylinder connection parts shown in figure 3, two reference samples of UF<sub>6</sub> with widely differing <sup>235</sup>U concentrations were analysed. Typical results for each sample are given below:

Sample 1: Natural UF <sub>6</sub>	Sample 2: Enriched UF <sub>6</sub> with 8.35% <sup>235</sup> U
Run 1 - % enrichment = 0.725 ± 0.006	Run 1 - % enrichment = 8.43 ± 0.06
Run 2 - % enrichment = 0.725 ± 0.008	Run 2 - % enrichment = 8.45 ± 0.03

As noted earlier, each result is the average of five readings. In all cases, the QMS reproduced the true values to within ~ 1 per cent. The observation of constantly higher values on the QMS is consistent with Balzers' experience under similar conditions [Huber *et al.* 1978]

It is unlikely that the accuracy of the Lucas Heights QMS enrichment monitor could be improved beyond that noted above without calibrating the system against known standards. Since this approach was incompatible with the aim of developing an automatic system suitable for unattended operation, it was not considered in the present study. Furthermore, the accuracy obtained without the use of standards is quite adequate for detecting the variations in enrichment expected in a centrifuge plant.

The final phase of this project involved the on-line measurement of UF<sub>6</sub> enrichment levels under circumstances which simulated an actual surveillance. During this phase, the system was usually controlled by ASO personnel from their office at Kings Cross, New South Wales [Mercer 1987]. Requests for enrichment measurements could be made *via* the ASO computer either automatically (*i.e.* at pre-

programmed times) or on demand. The results of these measurements appeared on visual display units (VDUs) located at Kings Cross and Lucas Heights. In addition, a printer installed at ASO produced a hard copy record of the results. A report by Hill and Wall [1987] describes work carried out by ASO as part of this project.

An indication of the enrichment monitor's on-line capability can be seen from the results presented in figure 10. The data in this figure were collected during a continuous 72-hour run of the gas centrifuge pilot plant. The use of arbitrary units was necessitated by the fact that we are not permitted to publish pilot plant performance data. Also plotted in figure 10 are the results of analyses of collected product samples (C). These were carried out by AAEC staff. The agreement in all cases is very good.

## 6. CONCLUSIONS

The aim of this project was to develop an on-line enrichment monitor for nuclear safeguards-related activities in gas centrifuge enrichment plants. An instrument, which used a QMS as the detecting element, was constructed by the AAEC and tested at Lucas Heights on a pilot-scale plant.

The AAEC pilot plant ceased operation on February 28, 1986 and all work associated with it had to be completed by that date. This deadline imposed a severe time constraint on the testing of the QMS system because operating and programming problems caused significant delays. In spite of these delays, the AAEC enrichment monitor performed remarkably well during the final two months of the project when it was subjected to intensive testing. Several minor faults were encountered and these have been duly noted.

Unfortunately, a lack of time prevented operation of the system in unattended, automatic mode for an extended period (*i.e.* several months or longer). However, on the basis of the experience gained, we are confident that this could be readily achieved with the present system.

## 7. ACKNOWLEDGEMENTS

Several ANSTO staff members were involved in the work described in this report. B.H Reid and J.T. Noorman made significant contributions to the assembly of the system, construction of components and the testing of the liquid N<sub>2</sub> filling system. The first version of the latter was assembled by M. Van Der Valk and subsequently modified by M.K. Dowson. Finally, mass spectrometric analysis of collected samples was performed by D.W. Metters. Their efforts are gratefully acknowledged.

## 8. REFERENCES

- Boldeman, J.W., Broe, H.G. [1982] - Gas phase enrichment monitor: preliminary operations manual and safety assessment. AAEC unpublished report.
- Carter, F.R., Van Der Valk, M. [1983] - Gamma ray spectroscopy for gas centrifuge on-line enrichment assay: relevant literature and preliminary results. AAEC unpublished report.
- Dowson, M.K. [1985] - A versatile low cost automated liquid nitrogen level controller. AAEC unpublished report.
- Egli, H.P., Huber, W.K., Rettinghaus, G., Irving, P. [1978]. A quadrupole mass spectrometer under computer control. *Proc 26th Annual Conf. on Mass Spectrometry and Allied Topics*, St. Louis, paper TD8.
- Evans, P.J., Hesse, E.W., Mercer, D.J., Rutherford, C.J., Whichello, J.V., Hill, J., Wall, K.A. [1987] - Safeguards experiments on a small centrifuge enrichment cascade. IAEA-SM-293/102, Vol. 1, p.303.
- Guzzi, G., Federico, A. [1983] - Use of a transportable quadrupole mass spectrometer for isotope analysis of uranium hexafluoride, IAEA-SM-260/51, Vol. 2, p.547.
- Hill, J., Wall, K.A. [1987] - BAAP II. ASO report (in preparation).
- Huber, W.K., Rettinghaus, G., Irving, P. [1978] - Isotope and impurity analysis of UF<sub>6</sub> and other corrosive gases with a computer controlled quadrupole mass spectrometer, *Proc 26th Annual Conf. on Mass Spectrometry and Allied Topics*, St. Louis, p.473.
- James, L.H., Carter, G. [1962] - *J. Electron. Control*, 13: 213.

- Jones, H.C. [1973] - On-stream monitoring of uranium isotopes. K-L-6300.
- Jones, H.C. [1975] - Evaluation of a quadrupole mass spectrometer for the isotope analysis of uranium hexafluoride. K-1872 (Rev.1).
- Kusahara, H.S., Rodrigues, C. [1979] - *NBS Special Publication No 582*, p.79
- Kusahara, H.S., Rodrigues, C. [1980]. *Trans Am. Nucl. Soc., Suppl.*, 33:6.
- Mercer, D.J. [1987] - Centrifuge enrichment plant surveillance project. ANSTO/E report (in preparation).
- Nagatoro, Y., Ochiai, K., Kaya, A. [1980] - *J. Nucl. Sci. Technol.*, 17:642.
- Nagatoro, Y., Suzuki, S., Ochiai, K., Kaya, A. [1978]- *Shitsuryo Bunseki*, 26:321 (in Japanese).
- Rettinghaus, G. [1978] - *Advances in Mass Spectrometry*, Vol. 7A. The Institute of Petroleum, London, p.495.
- Rutherford, C.J. [1987a] - A digital computer control system for a quadrupole mass spectrometer. ANSTO unpublished report.
- Rutherford, C.J. [1987b] - Computer programs for controlling a Balzers quadrupole mass spectrometer on the surveillance system of a uranium enrichment plant. ANSTO unpublished report.

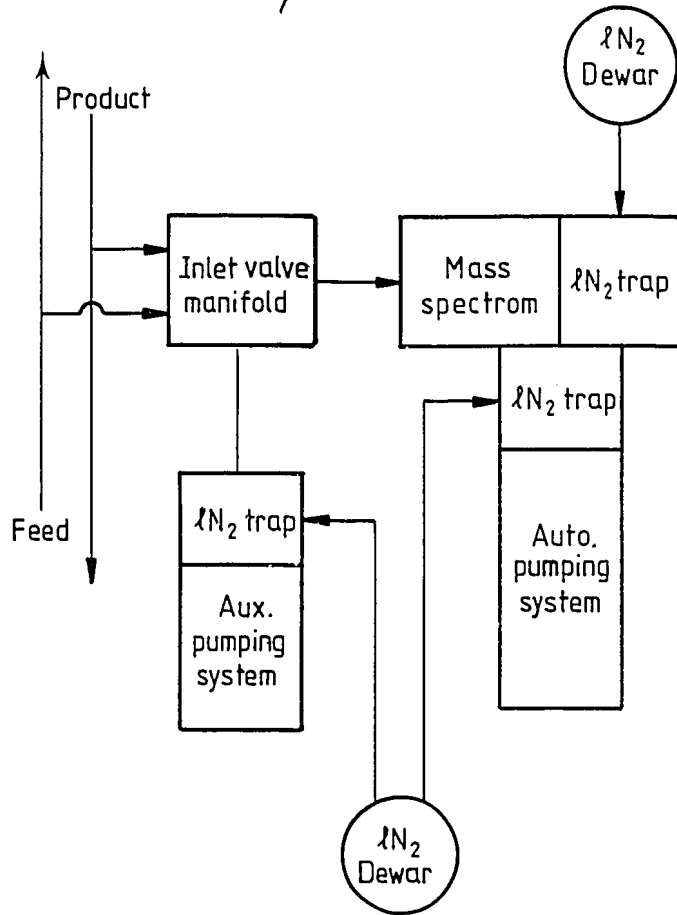
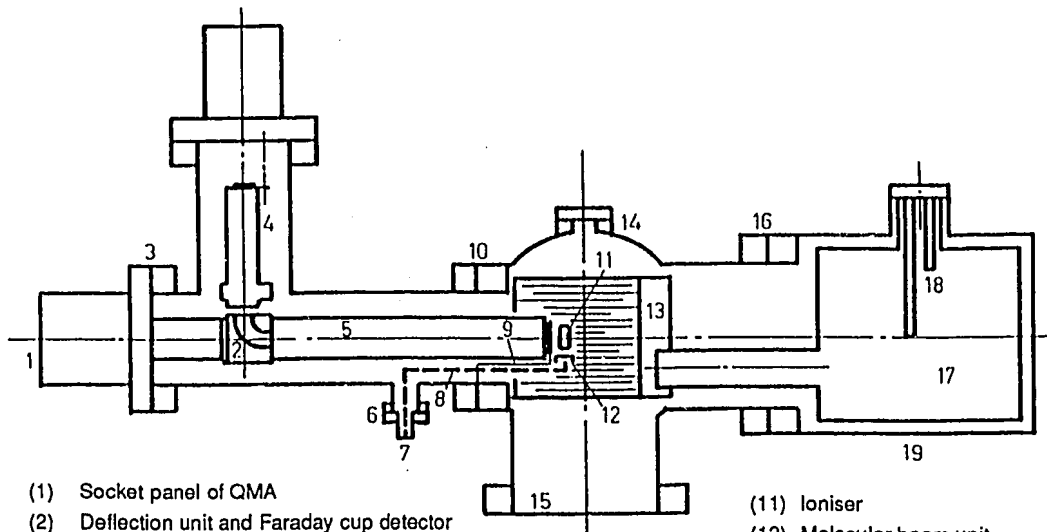

Figure 1 Block diagram of the system



- |  |   |
|--|---|
| (1) Socket panel of QMA                      | (11) Ioniser  |
| (2) Deflection unit and Faraday cup detector | (12) Molecular beam unit                              |
| (3) Flange CF 63.11                          | (13) Chevron trap $\lambda$ N <sub>2</sub> cooled     |
| (4) Multiplier                               | (14) Central recipient                                |
| (5) QMA 150                                  | (15) Pumping port                                     |
| (6) Flange CF 16                             | (16) Flange CF 100                                    |
| (7) Inlet port Swagelok 1/4"                 | (17) $\lambda$ N <sub>2</sub> container               |
| (8) Inlet tube 1 mm i.d.                     | (18) $\lambda$ N <sub>2</sub> sensor and filling pipe |
| (9) Heat diverter (copper sheet)             | (19) Trap housing                                     |
| (10) Flange CF 63.1                          |   |

Figure 2 Quadrupole mass analyser and vacuum chamber

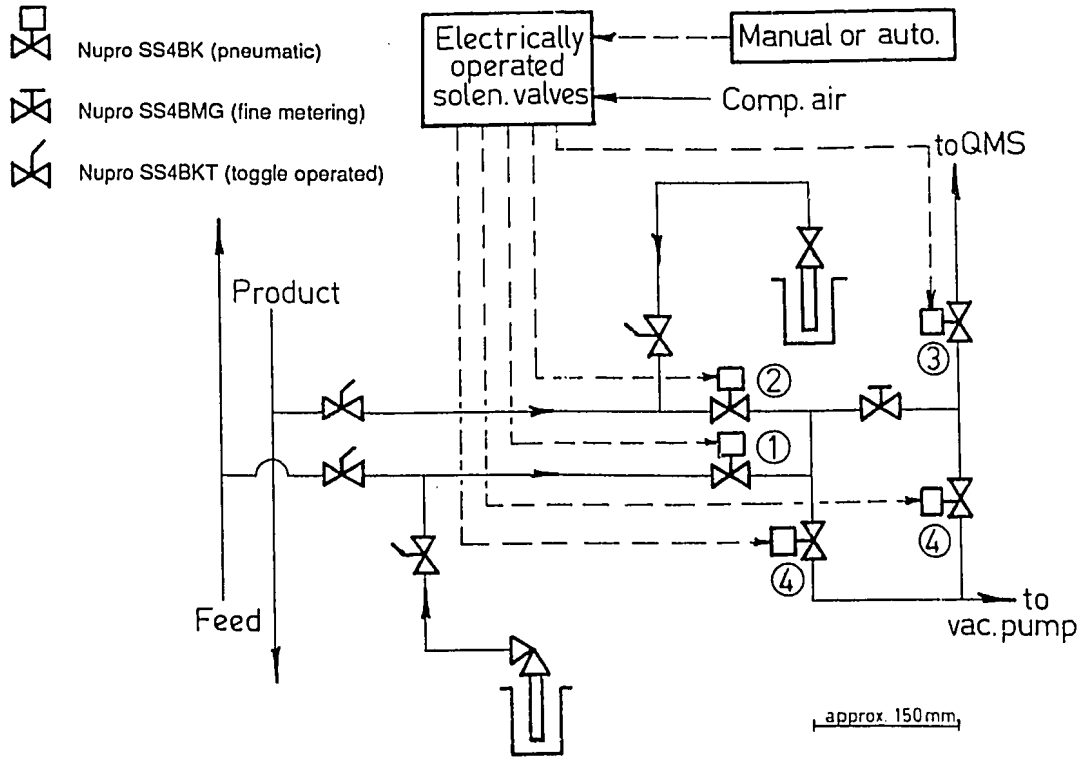

Figure 3 Gas inlet manifold

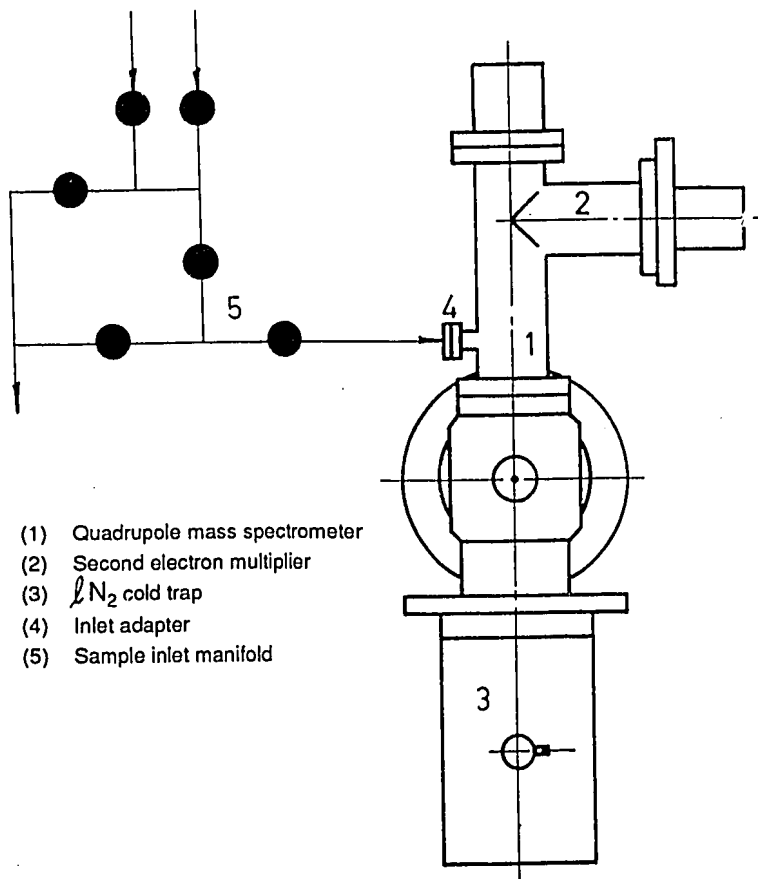

Figure 4 Top view of the system

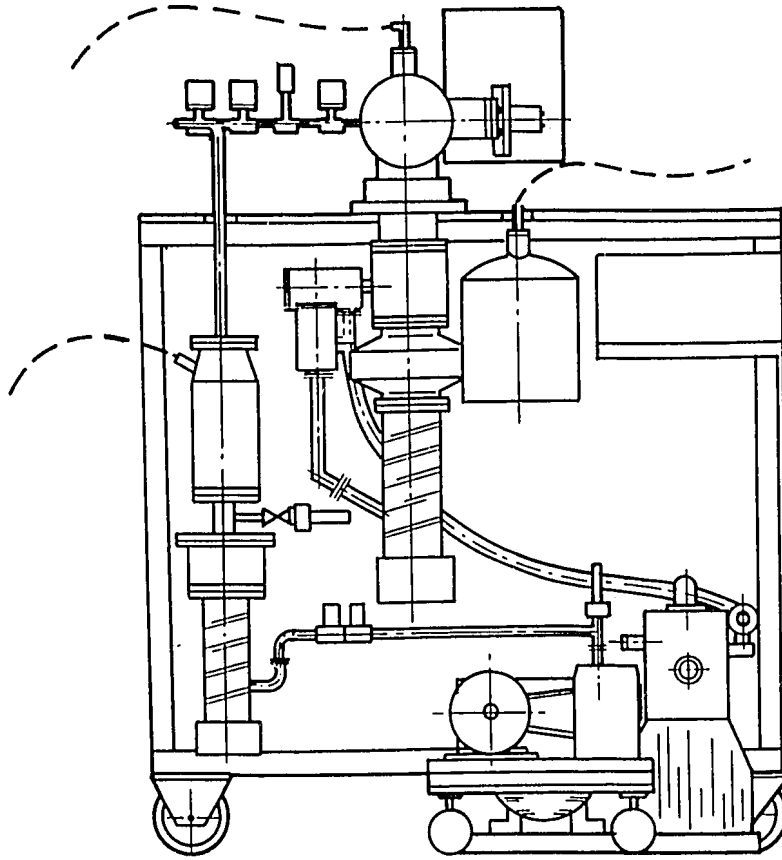
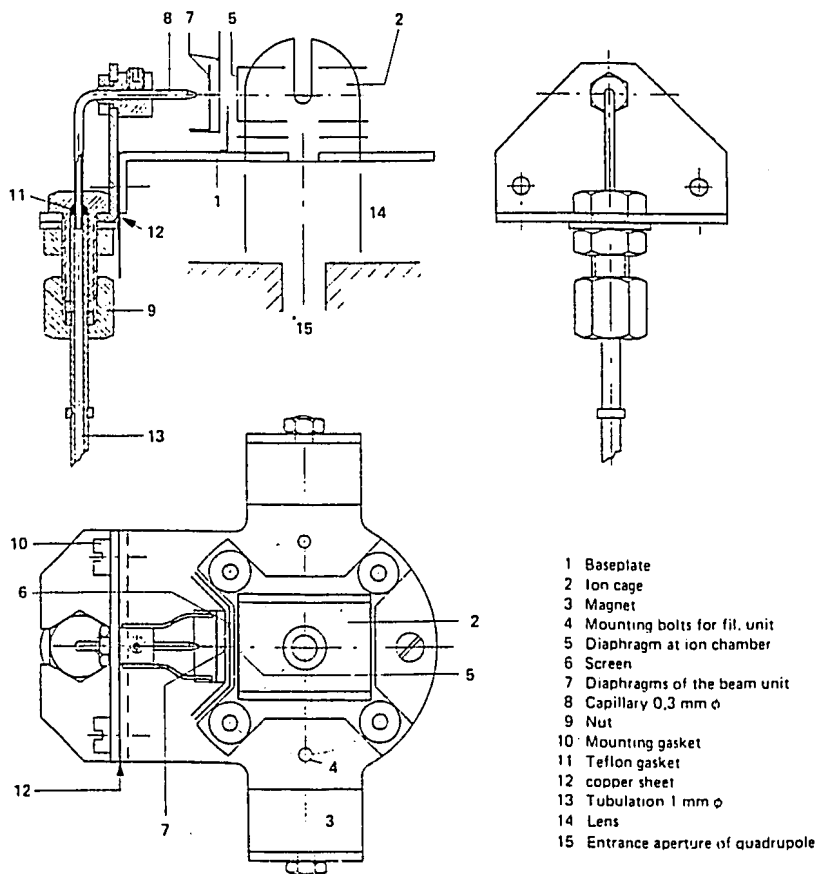

Figure 5 Side view of the system



- 1 Baseplate
- 2 Ion cage
- 3 Magnet
- 4 Mounting bolts for fil. unit
- 5 Diaphragm at ion chamber
- 6 Screen
- 7 Diaphragms of the beam unit
- 8 Capillary 0,3 mm  $\phi$
- 9 Nut
- 10 Mounting gasket
- 11 Teflon gasket
- 12 copper sheet
- 13 Tubulation 1 mm  $\phi$
- 14 Lens
- 15 Entrance aperture of quadrupole

Figure 6 Ion source and molecular beam inlet

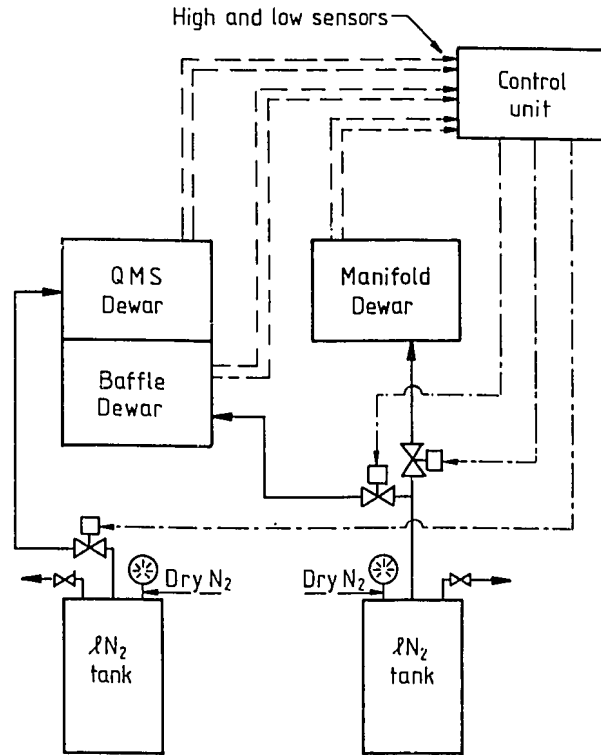

Figure 7 Liquid nitrogen filling system

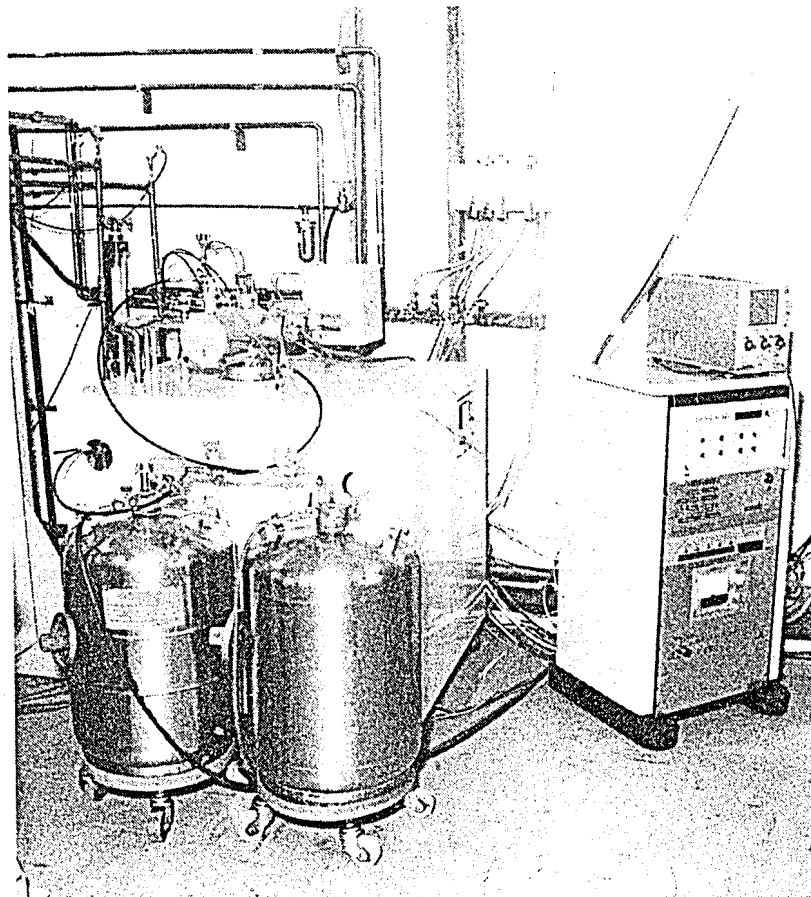

Figure 8 Photograph of AAEC enrichment monitor

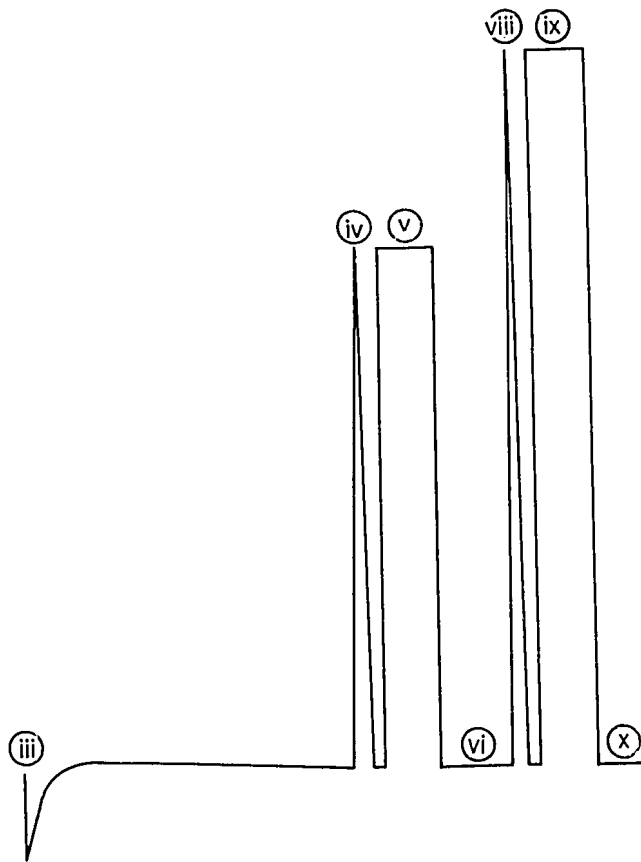

Figure 9 Measurement scheme for the determination of uranium isotope ratios. The numbers refer to steps described in section 4.

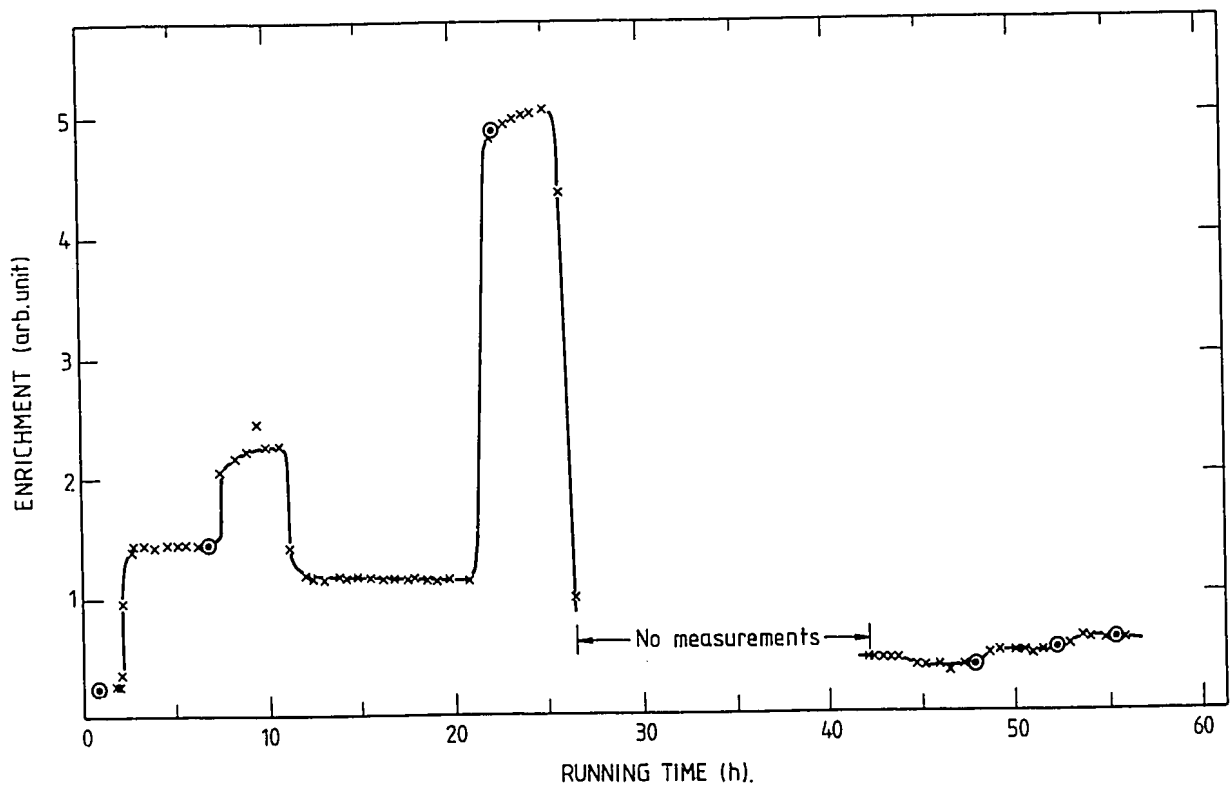

Figure 10 Record of product stream enrichment measurements for a 60-hour period