

ANSTO/E-768

AUSTRALIAN NUCLEAR SCIENCE & TECHNOLOGY ORGANISATION

LUCAS HEIGHTS RESEARCH LABORATORIES

THE DETERMINATION OF BARIUM-133 BY
EFFICIENCY EXTRAPOLATION

by

H. A. WYLLIE

ABSTRACT

A β -efficiency-extrapolation method for the determination of radioactivity makes use of a coincidence-counting system with two β -counting channels. In one channel, the efficiency is reduced by a linear gate which is controlled by a wave-form composer. The intermittent closing of the gate is a random process.

ISBN 1921268077

ISSN 10307745

ACKNOWLEDGMENTS

The author is grateful to the Management and Staff of ANSTO for the opportunity to carry out the experimental work described in this Report.

The author is indebted to Associate Professor Dimitri Alexiev for helpful discussions, and wishes to thank Yvonne A. van der Munnik for documentation processing.

CONTENTS

1.	INTRODUCTION	5
2.	DESCRIPTION OF ELECTRONIC MODULES	5
3.	CONSTANT-TRIGGER RECOGNITION POINT	6
4.	SETTING THE DEAD-TIME OF THE γ PARALYSIS-UNIT	8
5.	SETTING THE DEAD-TIME OF THE β PARALYSIS-UNIT	9
6.	SETTING THE DEAD-TIME OF THE ^{56}Fe PARALYSIS-UNIT	10
7.	RECORDING OF THE γ -PLATEAU	11
8.	RECORDING OF THE β -PLATEAU FOR BARIUM 133	13
9.	ENERGY CALIBRATION OF THE MCA CHANNELS	14
10.	BARIUM-133 γ -WINDOW LOWER LEVEL	15
11.	SETTING THE BARIUM-133 γ -WINDOW LOWER LEVEL	15
12.	ACQUISITION OF A BARIUM-133 SPECTRUM	16
13.	SETTING THE BARIUM-133 γ -WINDOW UPPER LEVEL	16
14.	RESOLVING TIME FOR INPUTS B AND A OF THE ORTEC 418 A COINCIDENCE MIXER	17
15.	RESOLVING TIME OF THE TENNELEC TC 404 A COINCIDENCE MIXER	19
16.	RESOLVING TIME OF THE TWO MIXERS; MEASURED SIMULTANEOUSLY BY COUNTING	21
17.	SETTING THE GANDY DELAY FOR BARIUM-133	23
18.	OPERATION OF THE LINEAR GATE	25

19.	ANTI-GATING OF THE 50 ns OUTPUT-PULSES EMITTED FROM THE 2 ND β -DISCRIMINATOR	26
20.	ADVANTAGE OF REDUCING TO A MINIMUM THE WIDTH OF THE 2 ND β -DISCRIMINATOR OUTPUT-PULSE	27
21.	“JITTER” IN THE OUTPUT-PULSES FROM THE 2 ND β -DISCRIMINATOR	27
22.	STANFORD ARBITRARY WAVE-FORM COMPOSER AND STANFORD WAVE GENERATOR	28
23.	WAVE-FORM POINTS	30
24.	THE THREE GRAPHS OF ACTIVITY VERSUS EFFICIENCY FUNCTION	35
25.	REFERENCES	35

TABLE OF FIGURES

Figure 1. Coincidence-counting system with two β channels. The β efficiency of one channel is reduced by random gating.	7
Figure 2. Constant-Trigger Recognition Point (CTRP).....	8
Figure 3. Setting the Dead-Time of the γ paralysis unit.	9
Figure 4. Setting the Dead-Time of the β paralysis unit.	10
Figure 5. Setting the Dead-Time of the $^{\text{S}}\text{E}$ paralysis unit.	11
Figure 6. $^{\text{S}}\text{E}$ paralysis-unit output-pulses during the Dead-Time setting.	11
Figure 7. Block Diagram of the γ -plateau system.	12
Figure 8. Block diagram of the system for recording the β -plateau.	13
Figure 9. Setting the Lower Level and the Upper Level of the γ Window.	16
Figure 10. Resolving Time using WIDTH G&DG.....	18
Figure 11. Resolving Time; normal setting of Ortec.	19
Figure 12. Resolving Time of TC404 A.....	20
Figure 13. Modification of the first stage of the γ -channel, for measuring Resolving Time by counting.	21
Figure 14. Average γ Pre-amp output-pulse.....	22
Figure 15. Gandy Delay in the Non-gated β -Channel.	22
Figure 16. Anti-Gating of pulses.	25
Figure 17. Advantage of 50ns pulses.....	26
Figure 18. Discriminator-output "jitter".	27
Figure 19. Stanford Wave-Generator CRO-display.....	28
Figure 20. Wave-form points.....	29
Figure 21. The Stanford Arbitrary Wave-form Composer lets β pulses through the Linear Gate during the "no-control-pulse" intervals.	29
Figure 22. The Stanford Arbitrary Wave-form Composer lets β pulses through the Linear Gate during the "no-control-pulse" intervals.	31

GLOSSARY OF SYMBOLS

List of symbols and what they refer to

ADC	Analogue-to-Digital Converter.
β DISC	β discriminator.
G&DG	Gate-and-Delay Generator.
MCA	Multi-Channel Analyser.
Par. Unit	Paralysis Unit
SCA	Single-Channel Analyser.
TAC	Time-to-Analogue Converter.
γ Amp.	Gamma Amplifier.

1. INTRODUCTION

This β -efficiency extrapolation method for the determination of radioactivity makes use of a coincidence-counting system with two β -counting channels which is shown in Figure 1.

In one of these channels the efficiency is reduced by a Linear Gate which is controlled by a Stanford Arbitrary Wave-Form Composer. The intermittent closing of the Linear Gate is a random process. Within the duration of a Stanford control-pulse, there is a maximum of one pulse arriving at the Linear-Gate Input; i.e., the minimum interval between Linear-Gate input-pulses is greater than the duration of the Stanford control-pulse.

One source was used in the production of the Barium-133 Efficiency-Extrapolation graphs. The activities and efficiencies for each point were calculated by means of equations of Bryant [1] and Wyllie [2]. For any one graphical point, the difference between the two calculated activities was less than 10^{-6} %.

2. DESCRIPTION OF ELECTRONIC MODULES

- (a) The Ortec 426 Linear Gate, used in the ANTI-coincidence mode, permits the passage of a positive pulse when the Stanford Wave Generator is not generating a control pulse.

The Wave-Generator "Function OUT" is connected to the "DC-Inhibit Input" on the Linear-Gate rear panel. The Linear-Gate three-position switch on the front panel is in the "DC-Inhibit" position.

- (b) In the diagrams, the symbol \square represents a terminator.
- (c) "Gandy G&DG" and "WIDTH G & DG" denote Ortec 416 A Gate-and-Delay Generators. Positive input-pulse specification: Amplitude $\geq 2V$. The output-pulse width and delay are adjustable.
- (d) The Ortec 567 Time-to-Amplitude Converter (TAC) in Figure 1 measures the interval between two SCA negative output-pulses which are accepted, respectively, at the TAC START and STOP. The amplitude of the "TAC Output" pulse of the TAC is proportional to the interval being measured, and it is represented on the Multi-Channel-

Analyser (MCA) graph by a channel number. The number of counts which accumulate in a channel is the number of measured intervals whose magnitudes are within the interval-range represented by that particular channel.

- (e) The β amplifier is an Ortec 460 Delay-Line Amplifier. Gain:- Fine, 0.6; Coarse, 500.
- (f) The γ amplifier is an Ortec 575 A Amplifier. Gain:- Coarse, 2; Fine, 2.5.
- (g) Three paralysis-units impose Dead-Times of 4 μ s which are exactly the same for each pulse entering the units. The Dead-Times can be set with considerable accuracy by the Double-Pulse Method, as described below.

3. CONSTANT-TRIGGER RECOGNITION POINT

Referring to Figure 1, the output pulse from the 1st β DISC. has a 500ns width and a 5V amplitude. This pulse becomes the input pulse to an ORTEC 551 SCA; its shape is shown in Figure 2.

The 551 SCA recognises the pulse at the Constant-Trigger Recognition Point (CTRP), which has been set half-way down the trailing edge of the pulse. Then, following an adjustable delay, the SCA output pulse is emitted.

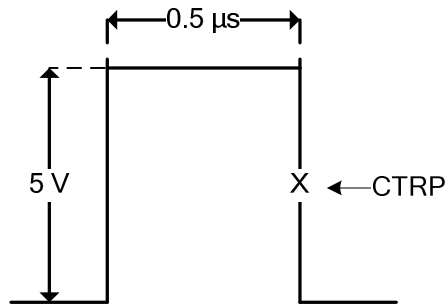

Figure 2. Constant-Trigger Recognition Point (CTRP).

4. SETTING THE DEAD-TIME OF THE γ PARALYSIS-UNIT

Referring to Figure 3, the G&DG is adjusted so that in the Le Croy-CRO channel 2, the OR-Gate output pulses are 4 μs apart. The paralysis-unit pot. is adjusted, so that in the Le Croy-CRO channel 3, the second of the paralysis-unit Front-OUT pulses is flickering. (The pot. reading is 1.446.) The width of the Rear-OUT pulse is 3.971 μs, which is close to the required Dead-Time of 4 μs.

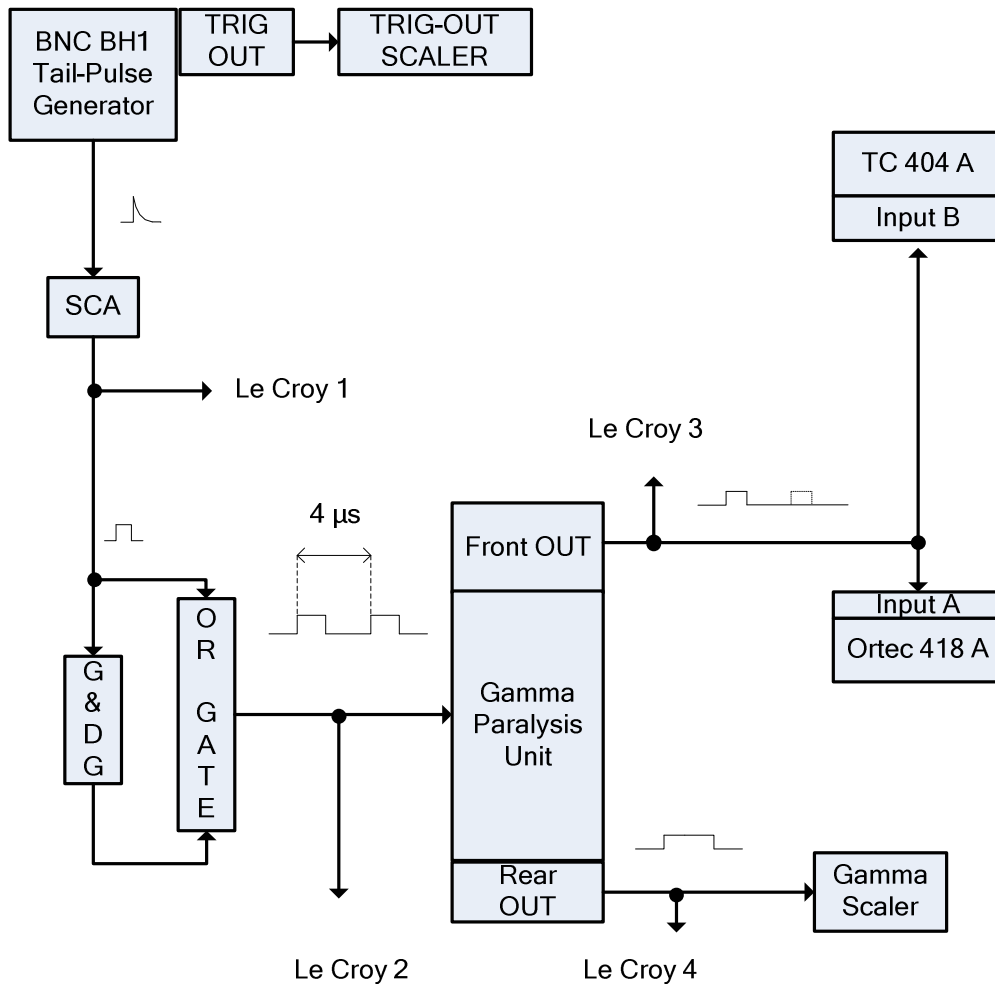

Figure 3. Setting the Dead-Time of the γ paralysis unit.

5. SETTING THE DEAD-TIME OF THE β PARALYSIS-UNIT

Referring to Figure 4, the G&DG preceding the OR Gate is adjusted so that, in Le Croy channel 2, the OR-Gate output pulses are $4 \mu\text{s}$ apart. The paralysis-unit pot. is adjusted, so that, in the Le Croy channel 3, the second of the pair of paralysis-unit output-pulses is flickering. The pot. reading is then 8.548, with Range set on 5.

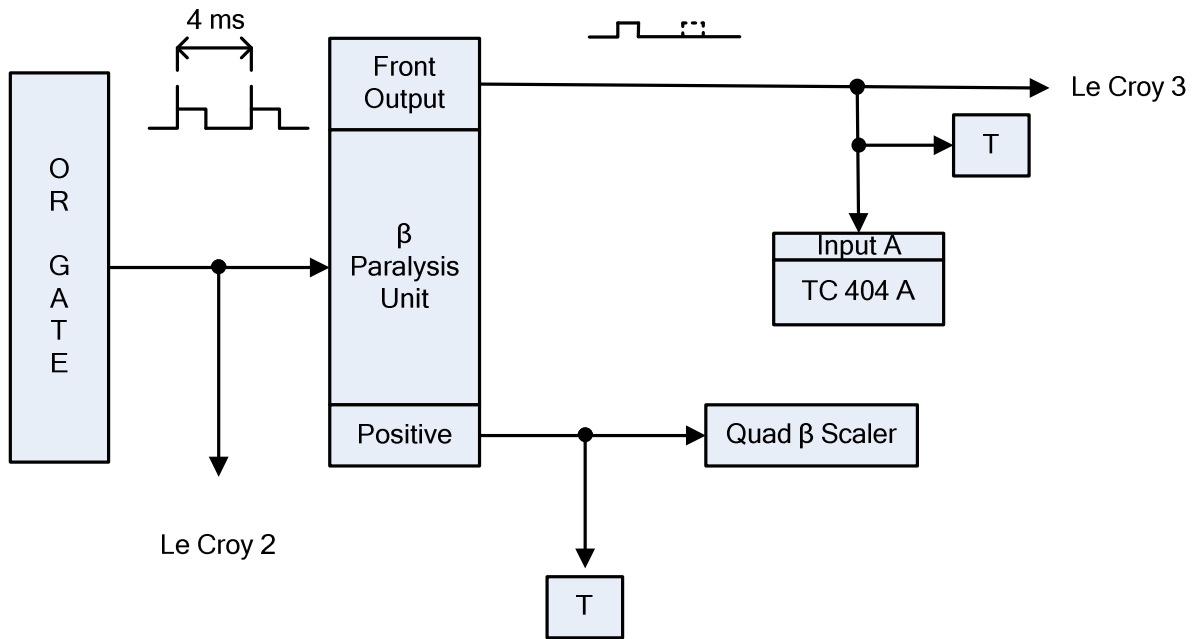

Figure 4. Setting the Dead-Time of the β paralysis unit.

6. SETTING THE DEAD-TIME OF THE $^S E$ PARALYSIS-UNIT

Referring to Figure 5, the OR-Gate output pulses are set 4 μ s apart, as described above. On the $^S E$ paralysis unit the “5 μ s” screw is adjusted so that, in Le Croy channel 3 (as shown in Figure 6), the amplitude of the second of the pair of paralysis unit output-pulses is reduced from 3 Volts to 2 Volts.

The adjustment of the screw is completed when a further very small reduction in the amplitude of the “triangular” pulse results in a sudden halving of the count-rate in the Dual β scaler, which becomes equal to the count-rate in the TRIG-OUT scaler in Figure 3.

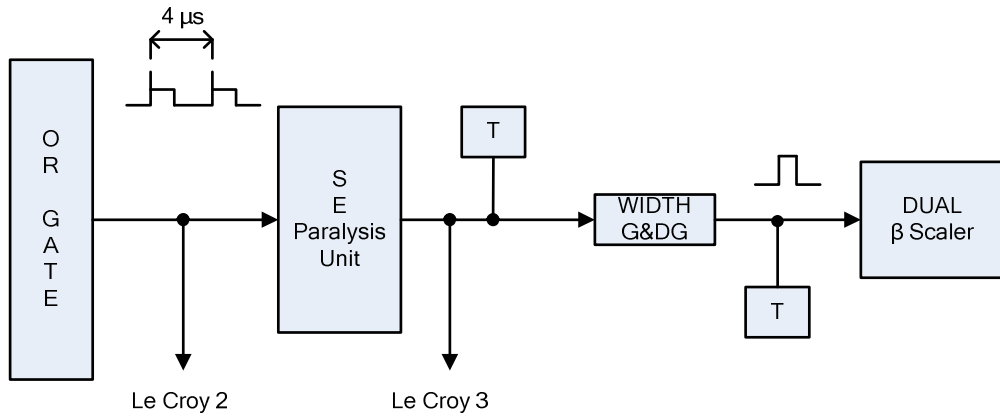

Figure 5. Setting the Dead-Time of the ^SE paralysis unit.

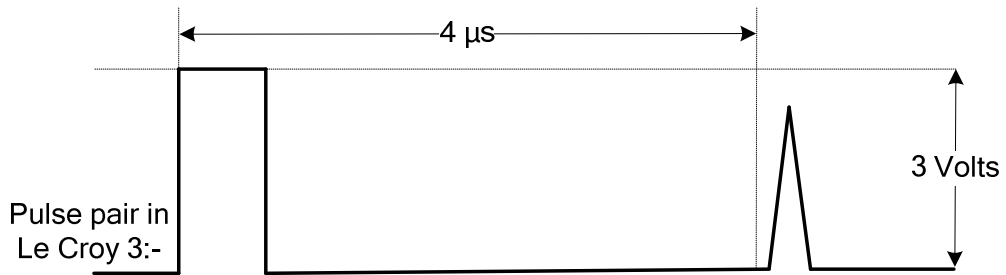

Figure 6. ^SE paralysis-unit output-pulses during the Dead-Time setting.

7. RECORDING OF THE γ -PLATEAU

The γ -plateau is obtained by means of the system in Figure 7. A Cobalt-60 source is used. Table 1 shows the number of counts accumulated in 300 seconds versus the phototube voltage. The minimum gradient occurs at 1150 volts.

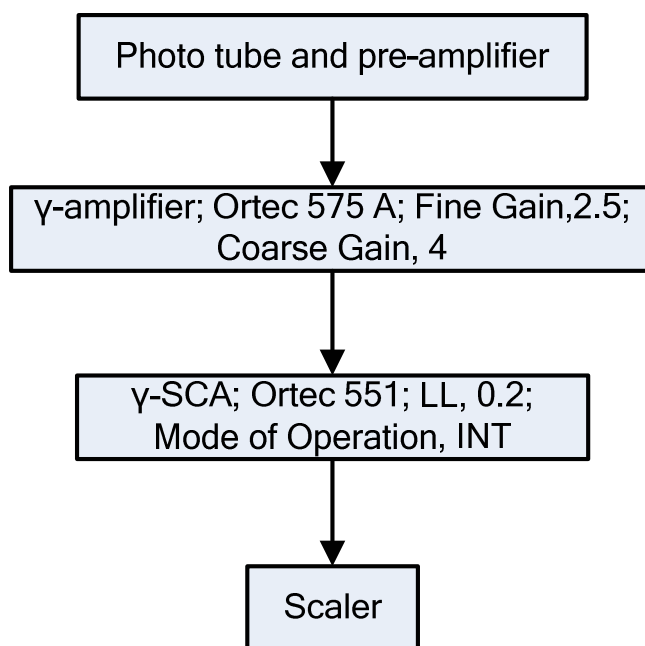

Figure 7. Block Diagram of the γ -plateau system.

Table 1. γ -Plateau data.

Phototube voltage, V	Counts accumulated in 300 seconds
850	78,644
900	85,579
950	89,493
1000	91,389
1050	92,947
1100	93,328
1150	93,539
“	93,530
“	93,764

Phototube voltage, V	Counts accumulated in 300 seconds
“	93,633
1200	93,568
1250	93,175
1300	93,954
1350	94,261
1400	94,602

8. RECORDING OF THE β -PLATEAU FOR BARIUM 133

The β -Plateau is obtained by means of the system in Figure 8, using Source No. 7393. The minimum gradient occurs at 2000 volts.

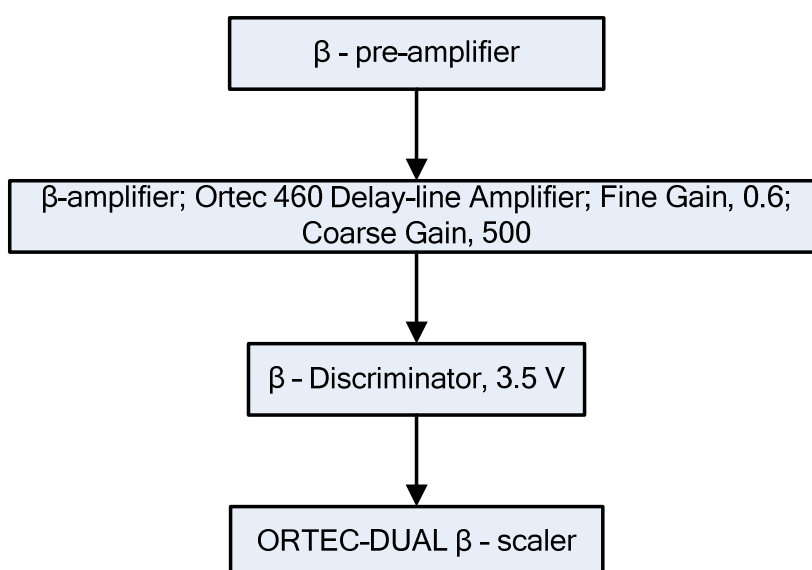

Figure 8. Block diagram of the system for recording the β -plateau.

9. ENERGY CALIBRATION OF THE MCA CHANNELS

The MCA channel-numbers used are the integers from 1 to 256.

256 = No. of MCA channels = ADC Range = ADC Gain. Amplifier Gain: Coarse, 2; Fine, 2.5 (to get the spectrum within the MCA screen).

A Cobalt-60 γ -spectrum was acquired, using Source No. 7331 (~ 1800 β -counts per second). The spectrum was “saved as” Cobalt 30.cnf.

The following Genie-2000 steps were carried out:

- (a) Edit, Sample Title, Co30.
- (b) Analyse, Peak Locate:
Unidentified 2nd Diff;
Channel 140 to channel 190,
 FW HM,
 Generate Report, Execute.
- (c) Print Report Window. The two peak-centroid channels are printed: 152.26, 172.05. The printed energy (keV) values are meaningless.
- (d) “Energy Only” calibration is carried out. The two Cobalt-60 peak energies are entered:-

Centroid Channel	Peak Energy (keV)
152.26	1173.238
172.05	1332.501

- (e) Step (b) is now repeated.
- (f) Print Report Window. The “Peak Locate Report” is shown below :-

Centroid Channel	Peak Energy (keV)
152.27	1173.33
172.07	1332.69

The MCA screen shows :-

Channel 152: 1171.1 keV.

Channel 172: 1332.1 keV.

- (g) The Report Window now has to be cleared by closing Cobalt 30.cnf, and then re-opening it. To keep the Energy-Calibration intact when Cobalt 30.cnf is closed, click YES in response to “save the changes?”.
- (h) Analyse, Execute Sequence, Spectral Data Report; Print Data Plot; Print Report Window.

10. BARIUM-133 γ -WINDOW LOWER LEVEL

G. Ratel [3] has discussed an International Comparison of activity measurements of Barium-133. He has stated that most participants used a threshold of at least 200 keV in the γ channel; i.e., they set the γ -SCA LL \geq 200 keV.

The MCA screen discussed above shows:- Channel 32: 205.4 keV. The LL is accordingly set on Channel 32.

11. SETTING THE BARIUM-133 γ -WINDOW LOWER LEVEL

Referring to Figure 9, the BH-1 settings are: Rise Time, 0.2 μ s; Fall Time, 0.1 μ s.

The BH-1 amplitude is adjusted so that the cursor on Channel 32 rises. The LL pot. on the γ -SCA is adjusted so that the γ -scaler count-rate is partly reduced; the LL pot. reading is 1.246.

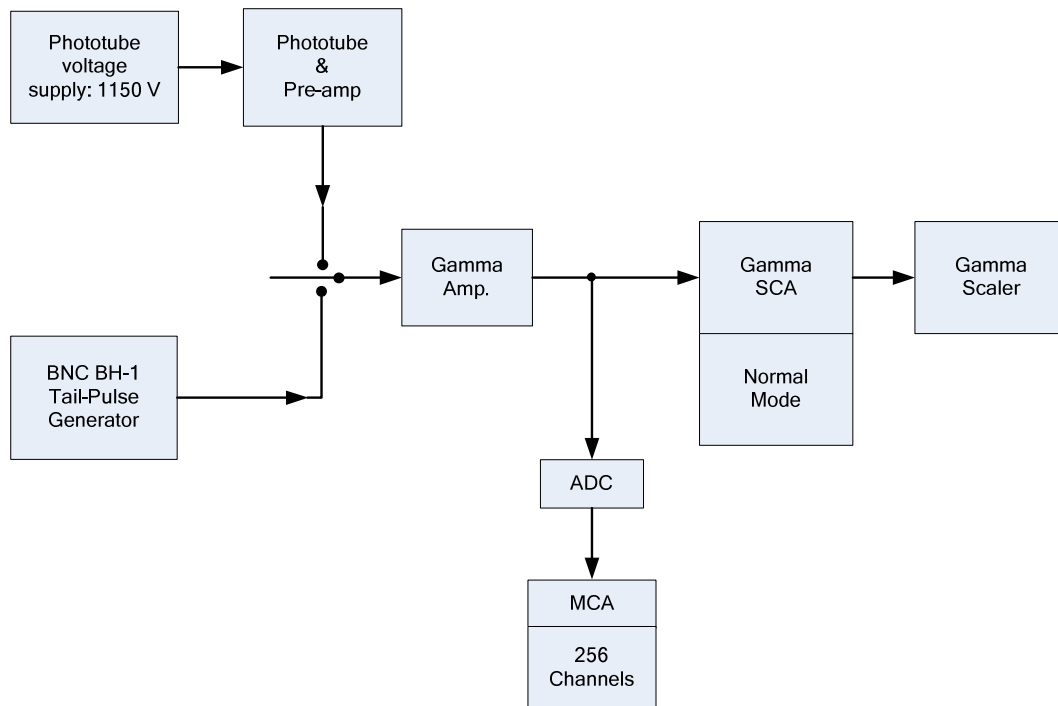

Figure 9. Setting the Lower Level and the Upper Level of the γ Window.

12. ACQUISITION OF A BARIUM-133 SPECTRUM

The spectrum “Barium 01.cnf” was acquired at ANSTO on the 9th January 2006. Real Time was 5000 seconds.

γ -EHT (obtained from γ plateau): 1150 V. γ -amp. coarse gain, 2; γ -amp. fine gain, 2.5. (The three latter values were used in the Energy Calibration of the MCA Channels.)

13. SETTING THE BARIUM-133 γ -WINDOW UPPER LEVEL

Inspection of the spectrum “Barium 01.cnf” suggests that an adequate γ -SCA upper level is channel 76; this corresponds to 559.5 keV. The BH-1 amplitude is adjusted so that the cursor on channel 76 rises. The UL pot. on the γ -SCA is adjusted so that the γ -scaler count-rate is partly reduced; the UL pot. reading is 2.974.

14. RESOLVING TIME FOR INPUTS B AND A OF THE ORTEC 418 A COINCIDENCE MIXER

The following sections, (a) and (b), describe the setting of 1.092 μs resolving time for Inputs B and A of the Ortec 418 A Coincidence Mixer.

(a) Setting the resolving time for Input B

Referring to Figure 10, the resolving time for Input B is designed by Ortec to be equal to the width of the WIDTH-G&DG output-pulse. This pulse is also referred to as the Early Pulse, and is observed in the Le Croy-CRO Channel 2.

To start with, the WIDTH G&DG is set on minimum delay. The Le Croy L.H. cursor is set on the rising edge of the Early Pulse at the 2V level. The R.H. cursor is set 1.092 μs to the right of the L.H. cursor. The delay in the DELAY G&DG is then set so that, in Le Croy channel 3, the rising edge of the Delayed Pulse is observed to coincide at the 2V level with the R.H. cursor.

Finally, the width control of the WIDTH G&DG is set, so that in Le Croy channel 4, the 418 A output-pulse is flickering. In Le Croy channel 2, the width of the Early Pulse at the 2V level is now observed to be about 1.109 μs .

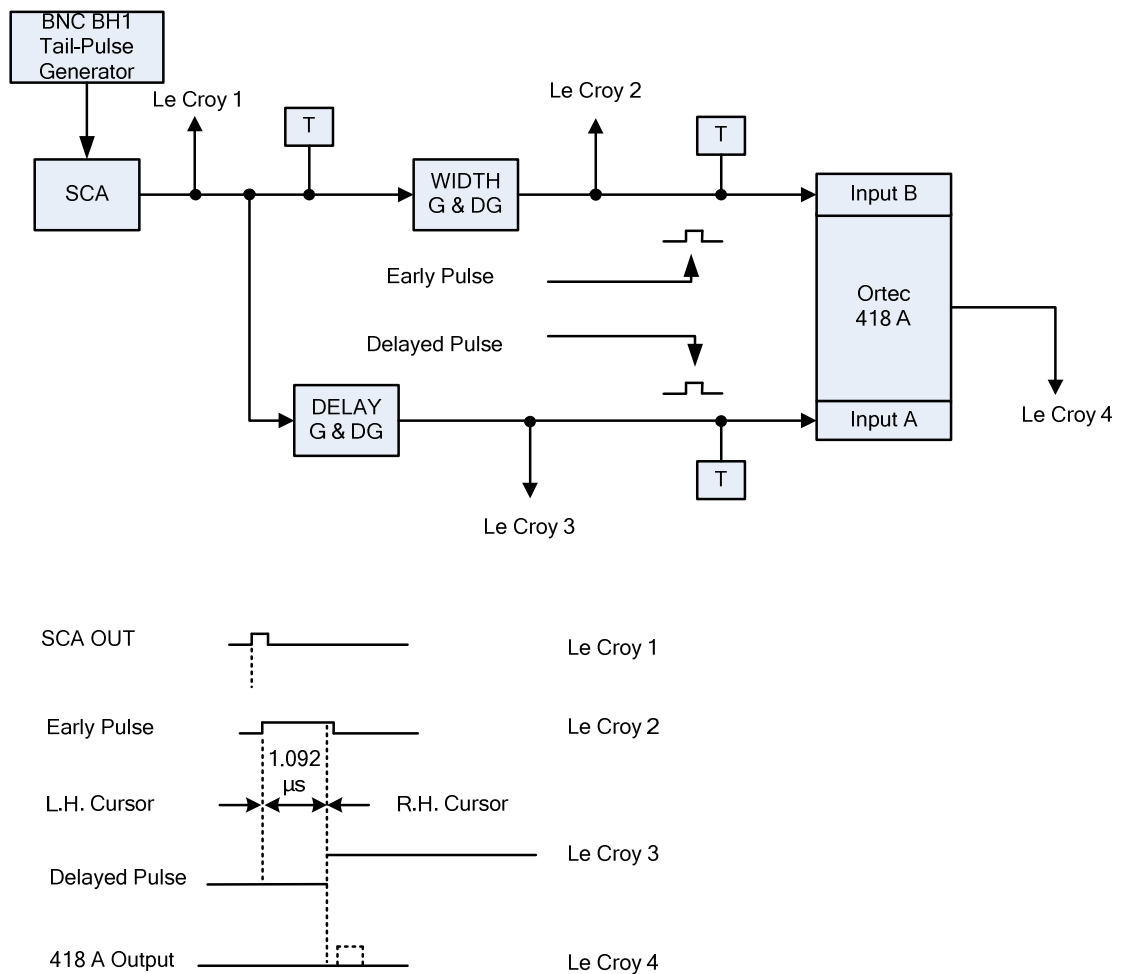

Figure 10. Resolving Time using WIDTH G&DG.

(b) Setting the resolving time for Input A.

Referring to Figure 11, the Le Croy L.H. cursor is set on the rising edge of the SCA-OUT pulse (the Early Pulse) at the 2V level. The R.H. cursor is set 1.092 μs to the right of the L.H. cursor.

The delay in the WIDTH G&DG is then set so that, in Le Croy channel 2, the rising edge of the Delayed Pulse is observed to coincide at the 2V level with the R.H. cursor.

Finally, the 418 A resolving-time pot. is set, so that in Le Croy channel 3, the 418 A output-pulse is flickering.

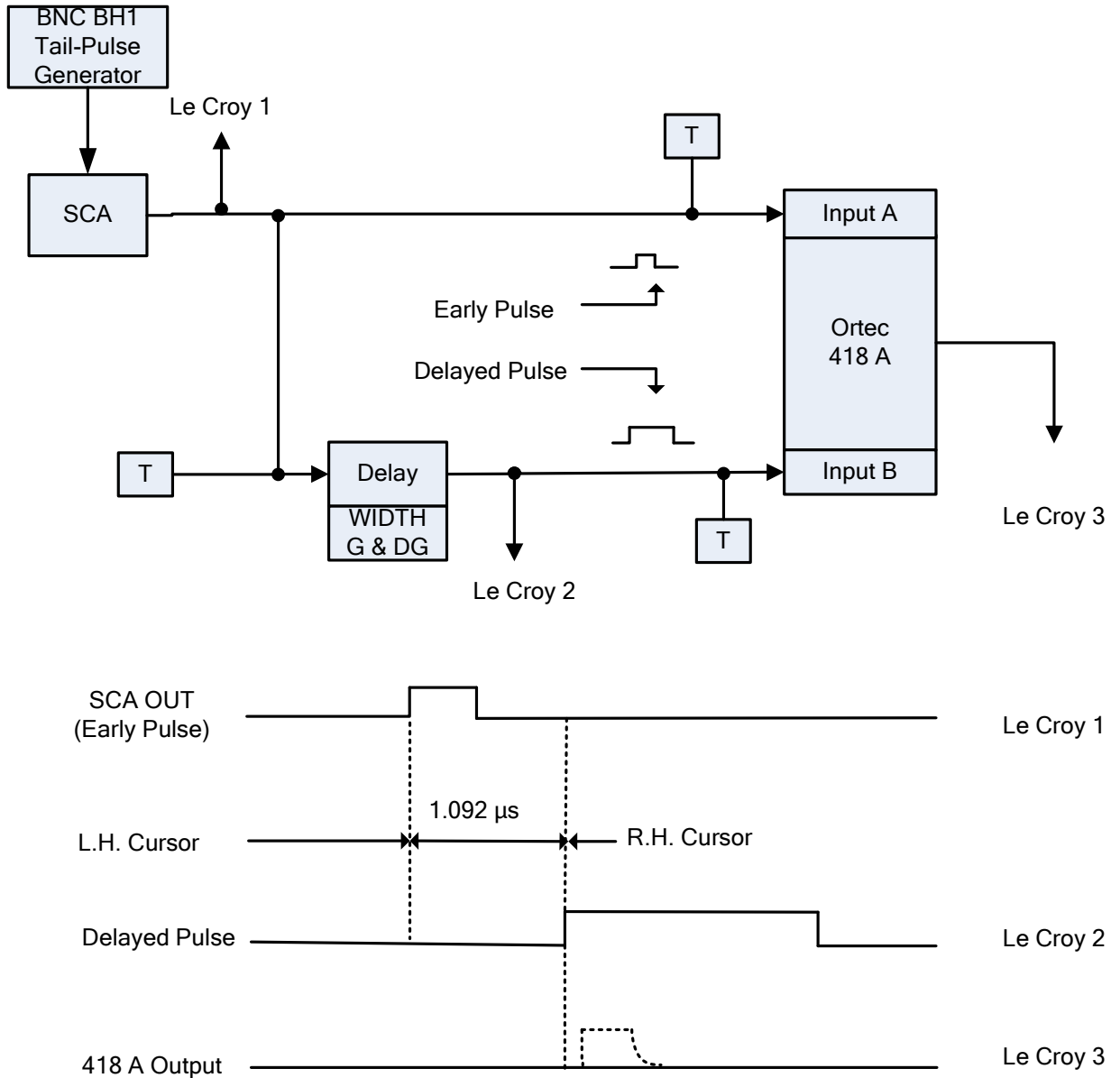

Figure 11. Resolving Time; normal setting of Ortec.

15. RESOLVING TIME OF THE TENNELEC TC 404 A COINCIDENCE MIXER

The multiplier switch of the TC 404 A is set on “× 25”. Referring to Figure 12, the G&DG delay is set so that the rise-time of the pulse in Le Croy channel 2 occurs 1.092 μs after the rise-time of the pulse in Le Croy channel 1. The Mixer pot. is set so that the Mixer output-pulse in Le Croy channel 3 is flickering.

The pulse in Le Croy channel 3 continues to flicker when the two inputs to the Mixer are interchanged. Thus, the Resolving Time is $1.092 \mu\text{s}$. The pot. is then set on 0.340.

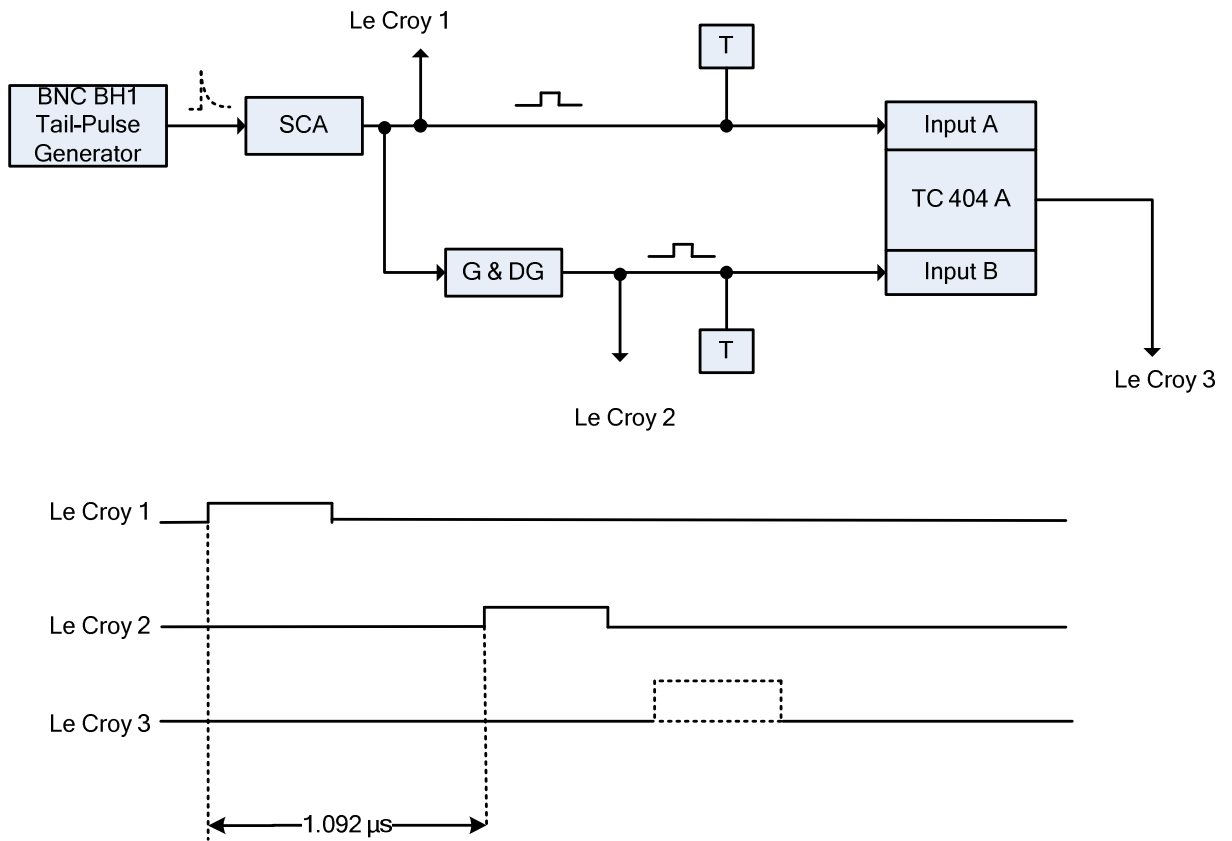

Figure 12. Resolving Time of TC404 A.

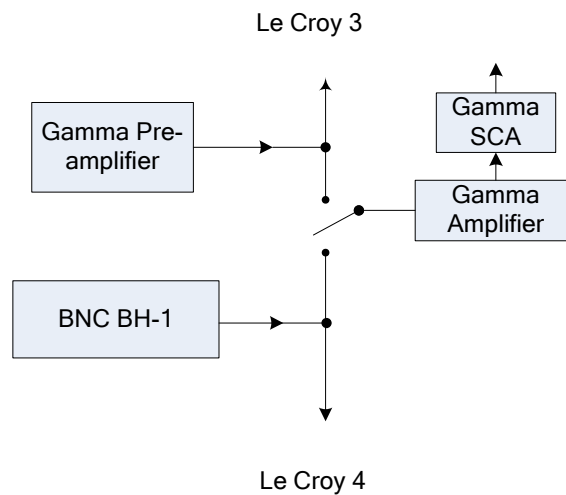

Figure 13. Modification of the first stage of the γ -channel, for measuring Resolving Time by counting.

16. RESOLVING TIME OF THE TWO MIXERS; MEASURED SIMULTANEOUSLY BY COUNTING

A Cobalt-60 source (Source No. 7331) is used. Referring to Figure 1, the Stanford Wave Generator is disconnected from the Linear Gate. The first stage of the γ -channel is modified as shown in Figure 13. The BNC BH-1 tail-pulse shape and amplitude are adjusted to replicate those of the average γ pre-amp. output pulse (see Figure 14).

The Le Croy CRO settings are :-

1 μ s per division;

Channels 3 and 4: 0.5 V per division, DC;

triggered on channel 3.

The BH-1 settings are :-

Rise time and fall time: 0.5 μ s.

The BH-1 amplitude is set so that the γ -amplifier output pulse fits between the LL and UL of the γ SCA.

If the BH-1 repetition rate (“frequency”) is set at 100 times the γ Pre-amp. count rate, and the Le Croy is single-triggered, the pulse in Le Croy channel 3 is often accompanied by a similar BH-1 pulse in Le Croy channel 4 at about the same time.

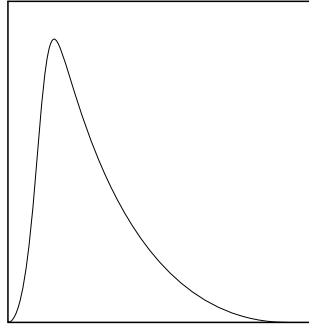

Figure 14. Average γ Pre-amp output-pulse.

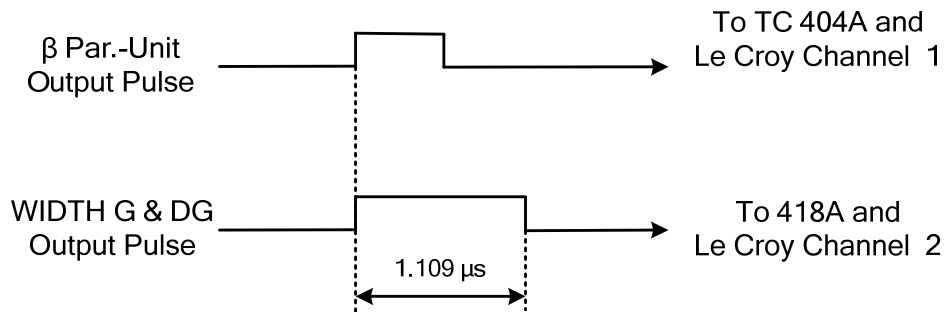

Figure 15. Gandy Delay in the Non-gated β -Channel.

Resolving-time measurements by counting are carried out with the BH-1 output connected to the γ -Amplifier input. The BH-1 repetition rate is adjusted to be slightly greater than the β count rate. The resolving times are calculated by the equation derived by A.P. Baerg [4] :-

$$\text{Resolving time (} \mu\text{s)} = \frac{\text{Coinc. counts} \times \text{Counting period} \times 10^6}{2 \times \beta \text{ counts} \times \text{Periodic counts}},$$

the counting period being measured in seconds. The counting results are given in Table 2.

Table 2. Resolving Time by counting.

Counting Period (secs)	BH-1 Periodic Counts	Mixer	β Counts	Coincidence Counts	Resolving Time (μ s)
60,000	91,676.526	TC 404 A	86,914,383	286,966	1.0804
		Ortec 418 A	86,916,249	288,997	1.0881
60,000	91,677.034	TC 404 A	86,887,137	288,578	1.0868
		Ortec 418 A	86,888,948	290,554	1.0943

The average values of the Resolving Times are :-

TC 404 A Mixer: 1.0836 μ s.

Ortec 418 A Mixer: 1.0912 μ s.

17. SETTING THE GANDY DELAY FOR BARIUM-133

(a) In the Gated β -Channel

β -EHT = 2000 V.

β -Amp. coarse gain = 500; fine gain = 0.6.

β -Disc. = 3.5 V.

β -SCA: minimum delay.

γ -EHT = 1150 V.

γ -Amp. coarse gain = 2; fine gain = 2.5.

γ -SCA delay = 2.204 μ s.

TAC Range = 1 μ s.

256 = No. of MCA channels = ADC Range = ADC Gain.

The β -SCA NEG OUT is connected to TAC START;

The γ -SCA NEG OUT is connected to TAC STOP.

A Delay Spectrum is acquired on the MCA in 60,000 seconds, and is “saved as” Gan Del.cnf. On the MCA, “Integral” denotes the number of counts between the two markers.

If the computer has been turned off after saving the Delay Spectrum, the Gandy Delay is set in the Gandy G&DG as follows:-

Open Gan Del.cnf. The L.H. marker is moved to channel 70, the R.H. to channel 200. Thus, “Integral” includes all the True Coincidences. Integral is reduced to Half-Integral (as near as possible) by moving the R.H. marker leftwards to the appropriate channel.

Open “Data-Source DET-01”. The Gandy-G&DG Delayed-Marker Output is connected to TAC-STOP. The R.H. marker is moved to “the appropriate channel”. Acquiring is commenced. The delay pot. of the Gandy G&DG is adjusted so that the R.H. marker rises.

The Gandy Delay has now been set in the Gated β -Channel.

(b) In the Non-gated β -Channel

Referring to Figure 15, it is likely that at the instant of a β pulse entering the Tennelec TC 404 A Mixer, a β pulse from the same disintegration will enter the ORTEC 418 A Mixer. The two pulses are observed in Le Croy-CRO channels 1 and 2.

The delay in the WIDTH G&DG is adjusted so that the WIDTH-G&DG output-pulse rises at exactly the same instant as the β Paralysis-Unit output-pulse rises. The adjustment is made at the 2 Volt level.

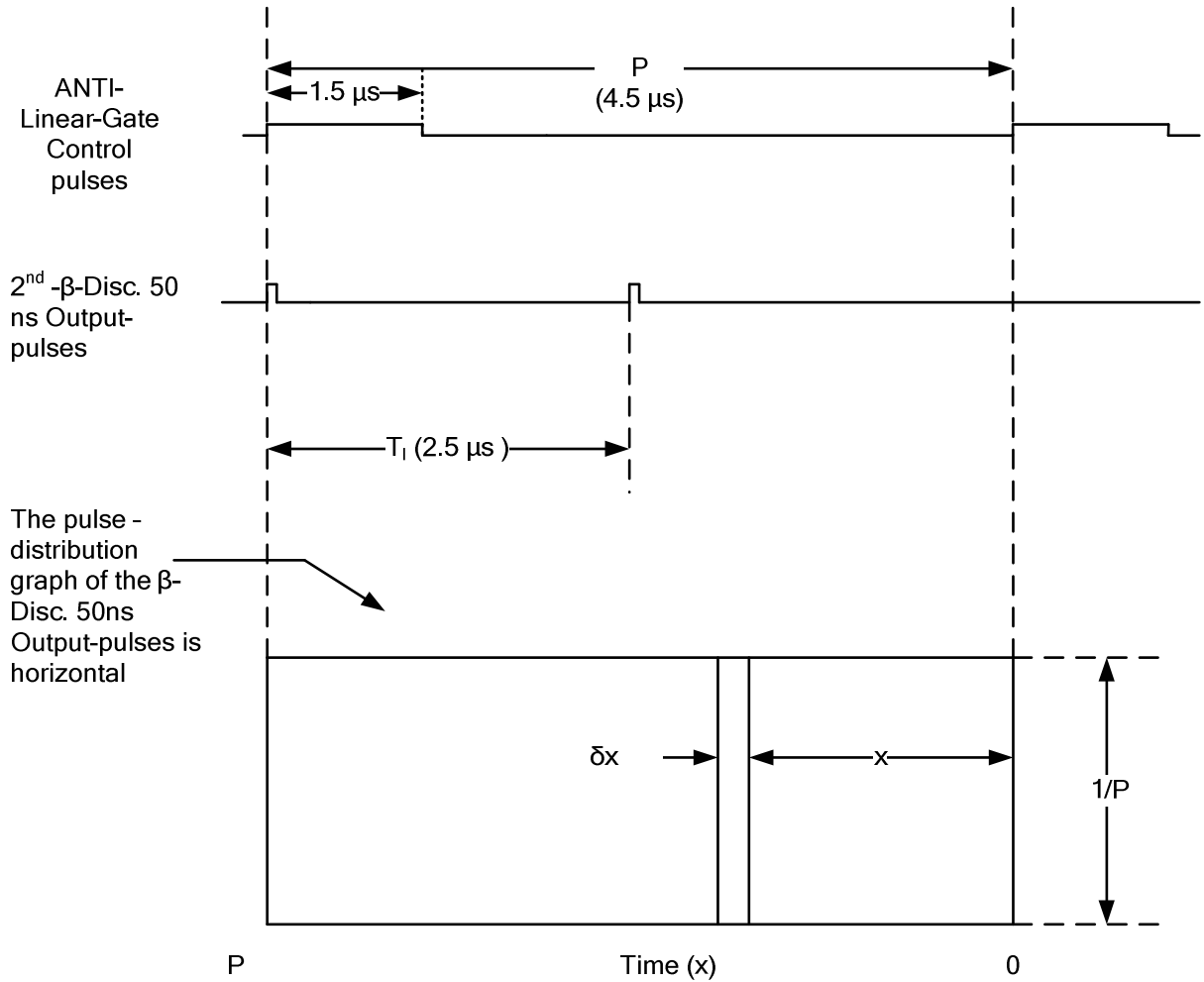

Figure 16. Anti-Gating of pulses.

18. OPERATION OF THE LINEAR GATE

Referring to Figure 1, the Linear Gate is used in the ANTI mode. Stanford Wave-Generator Function-OUT pulses (which can be seen in the Le Croy-CRO channel 3) control the Linear Gate.

While a control pulse is entering the Linear Gate, the Gate is closed to pulses from the 2nd β -Discriminator.

19. ANTI-GATING OF THE 50 ns OUTPUT-PULSES EMITTED FROM THE 2ND β -DISCRIMINATOR

Referring to Figure 16, the Period (denoted by P) is the interval between the rising edges of 2 consecutive control pulses. T_I , the delay in the Ortec 551 “ T_I SCA”, is the minimum interval between two consecutive 2nd- β -Discriminator 50ns Output-pulses. The “ T_I SCA” prevents a control pulse from ANTI-Gating more than one 50ns pulse. The fraction of 50ns pulses which are not ANTI-Gated = $(4.5 - 1.5) / 4.5 = 2/3$.

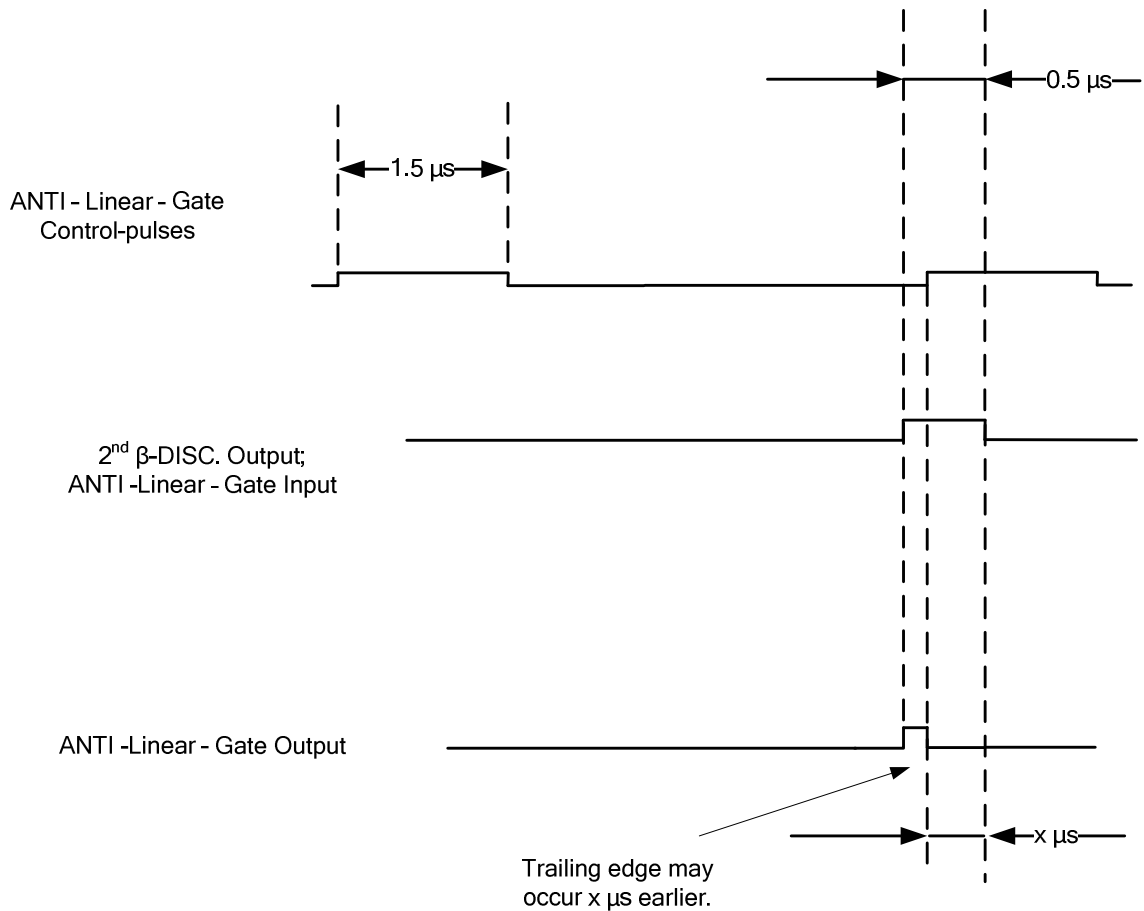

Figure 17. Advantage of 50ns pulses.

20. ADVANTAGE OF REDUCING TO A MINIMUM THE WIDTH OF THE 2ND β -DISCRIMINATOR OUTPUT-PULSE

Referring to Figure 1, consider the temporary increase of the 2nd β -Discriminator Output-pulse-width from 50ns to 0.5 μ s.

Referring to Figure 17, there is over-lapping of the R.H. ANTI-Linear-Gate Control-pulse and the ANTI-Linear-Gate Input-pulse.

Because of the partial ANTI-Gating, the trailing edge of the ANTI-Linear-Gate Output-pulse occurs x μ s earlier; and as a result the recognition of the pulse by the β -SCA occurs x μ s earlier.

At Input A of the TC 404 A Mixer, the Input-pulse arrives x μ s earlier, thus disturbing the setting of the Gandy Delay.

Reduction of the 2nd β -Discriminator Output-pulse width to 50ns keeps x to a minimum.

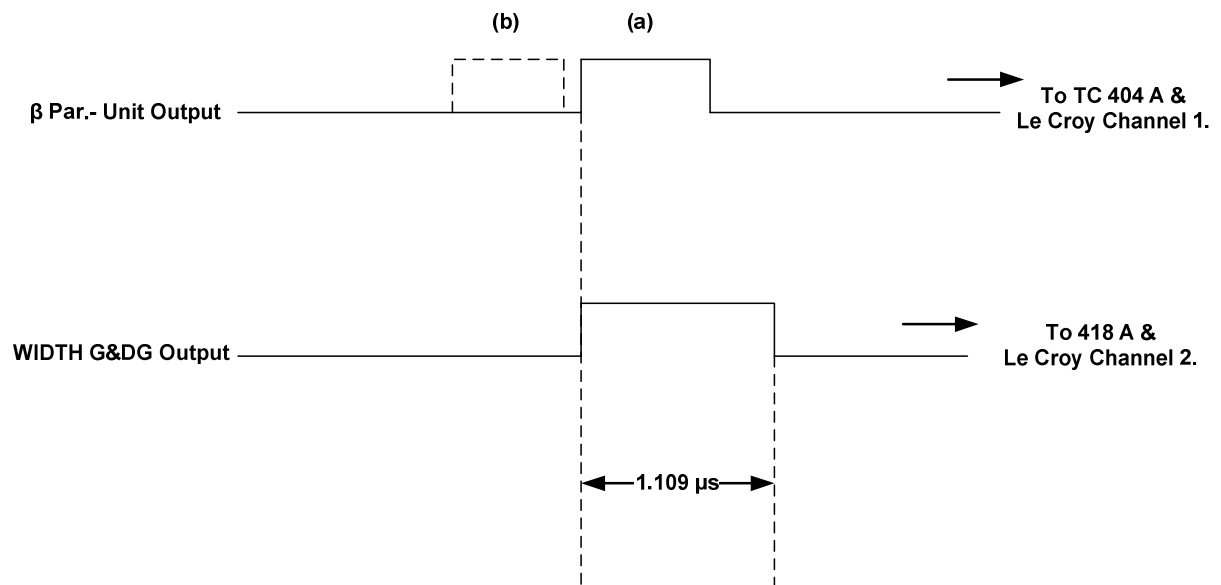

Figure 18. Discriminator-output "jitter".

21. "JITTER" IN THE OUTPUT-PULSES FROM THE 2ND β -DISCRIMINATOR

To study more effectively the "jitter" of the 2nd β -Discriminator Output, the Output-pulse-width was temporarily increased to 0.5 μ s. The pulses in Figure 18 were then observed.

The Le Croy CRO was triggered in channel 2; “Single Trigger” was used. The β Paralysis-unit Output was mostly in the region (a); it oscillated between (a) and (b).

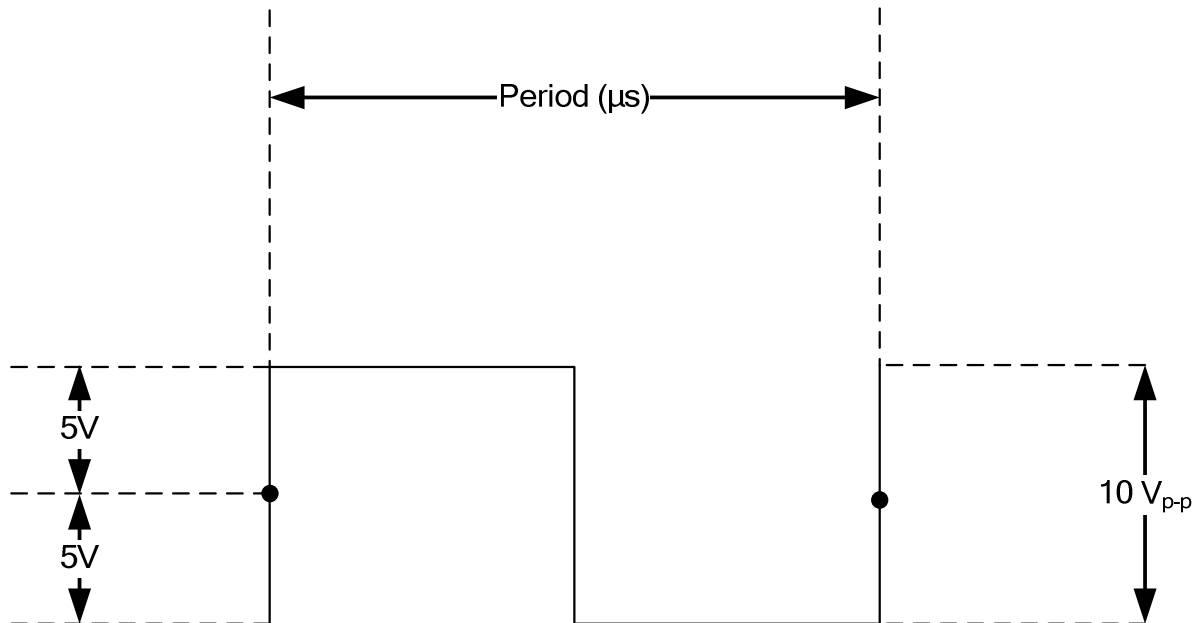

Figure 19. Stanford Wave-Generator CRO-display.

22. STANFORD ARBITRARY WAVE-FORM COMPOSER AND STANFORD WAVE GENERATOR

Referring to Figure 1, the ANTI Linear-Gate is controlled by the Arbitrary Wave-form Composer and the Wave Generator.

The Le Croy-CRO display in Figure 19 is produced by using the Generator without the Composer. V_{p-p} denotes Volts, peak to peak.

The Stanford Wave Generator is more conveniently used in combination with the Stanford Arbitrary Wave-form Composer, thus producing the Generator wave-shape shown in Figure 20. The Linear-Gate Control-pulse width is $1.766 \mu s$.

A required interval which alternates with the control pulse = $1.938 \mu s$. Period (μs) = $1.938 + 1.766 = 3.704$. Details of production of this wave-shape are described below.

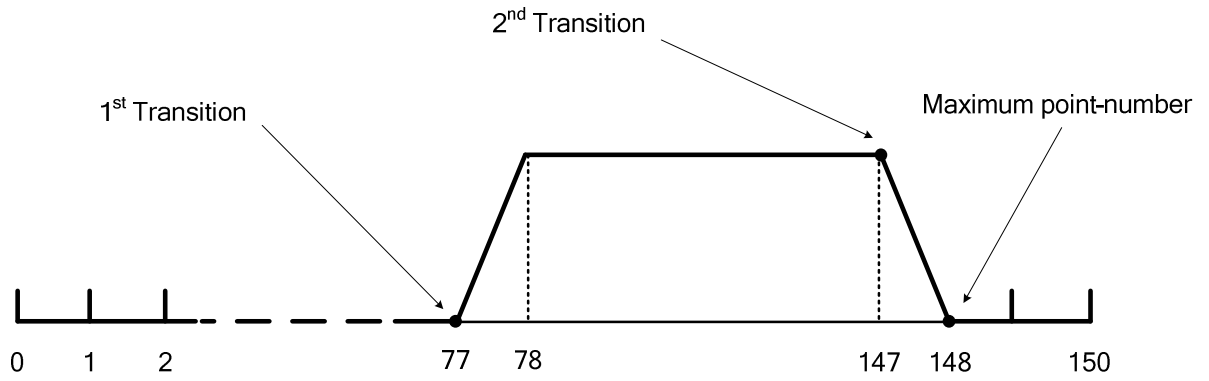

Figure 20. Wave-form points.

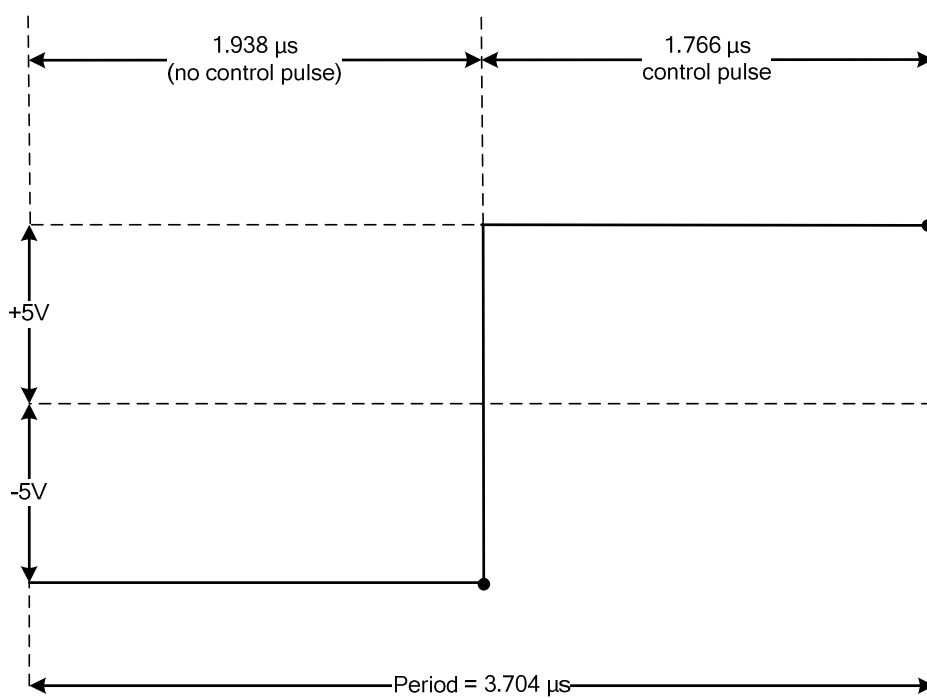

Figure 21. The Stanford Arbitrary Wave-form Composer lets β pulses through the Linear Gate during the “no-control-pulse” intervals.

23. WAVE-FORM POINTS

Referring to Figure 21, we have to set a certain number of equally spaced wave-form “points” along the base of the computer screen;

$$\text{the total number} = \text{Period } (\mu\text{s}) \times \text{Sampling Frequency (MHz)} = 3.704 \times 40 = 148.16.$$

The number actually set is 148. Note that the number which appears at the right-hand end of the screen is 150.

The number of the point where the first transition occurs

$$\begin{aligned} &= \text{Maximum point-number} \times \frac{\text{no-pulse interval}}{\text{Period}} \\ &= 148.16 \times \frac{1.938}{3.704} = 77.52, \text{ rounded to } 77. \end{aligned}$$

The number of the point where the second transition occurs is 147. This is the highest number permitted, the fall time of the trailing edge being the interval between points 147 and 148.

40 MHz is the default value of the Sampling Frequency.

The frequency corresponding to the Period, 3.704 μs , is $1,000,000 / 3.704 = 269,978 \text{ s}^{-1}$.

The control-pulse scaler-rate is 270, 264 s^{-1} .

The Wave Generator continues to work after the Waveform-Composer program has been closed. If the Wave Generator is switched off and then on, it will work as it did before it was switched off.

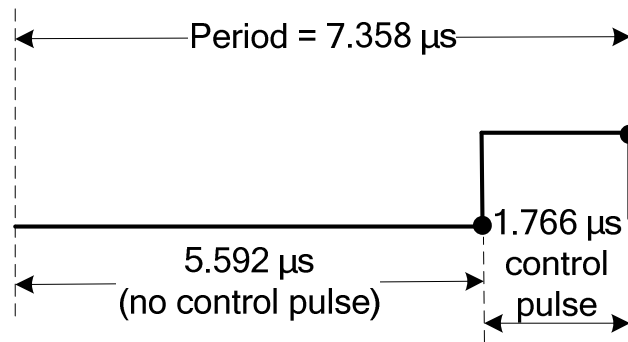
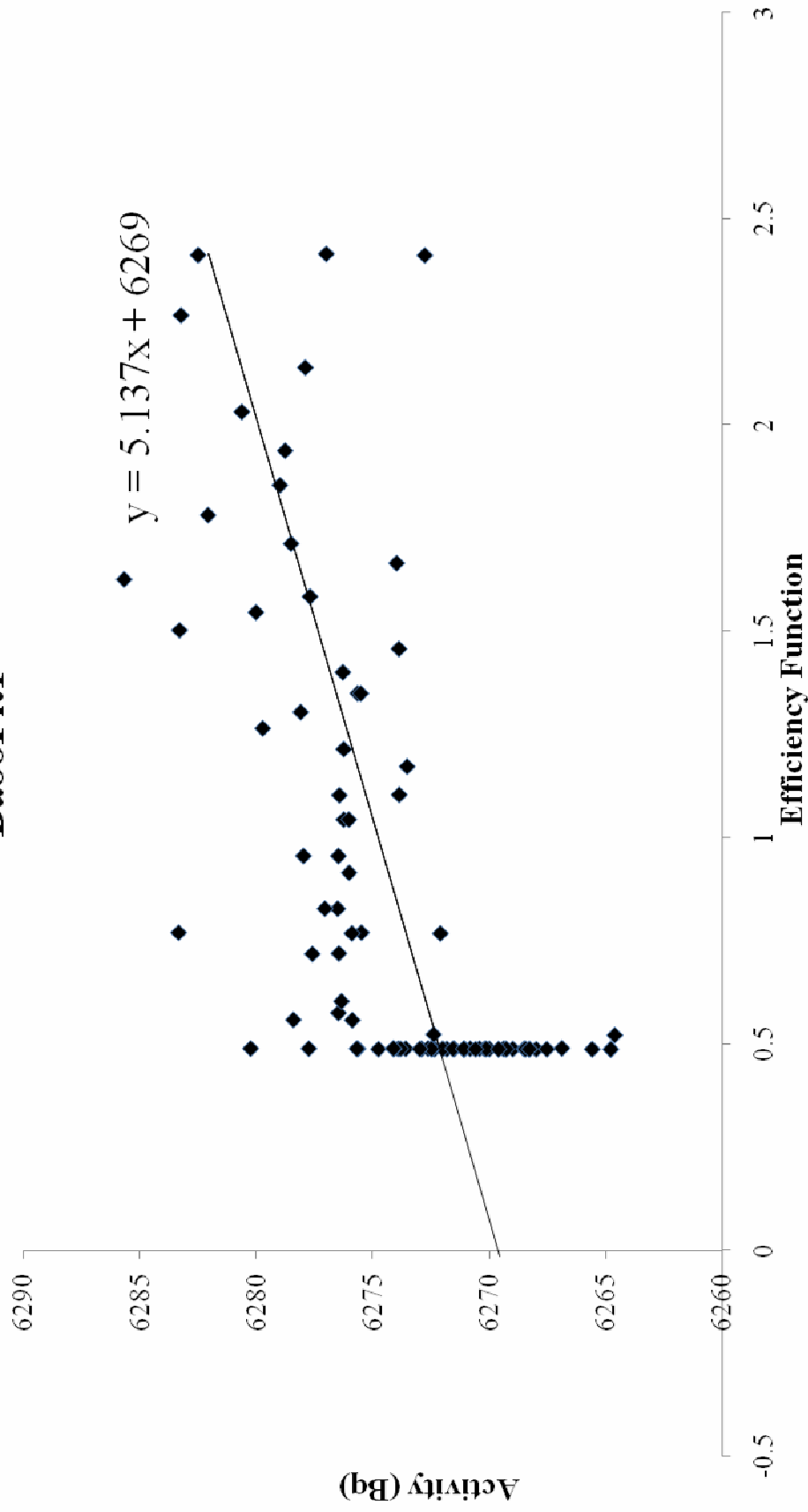
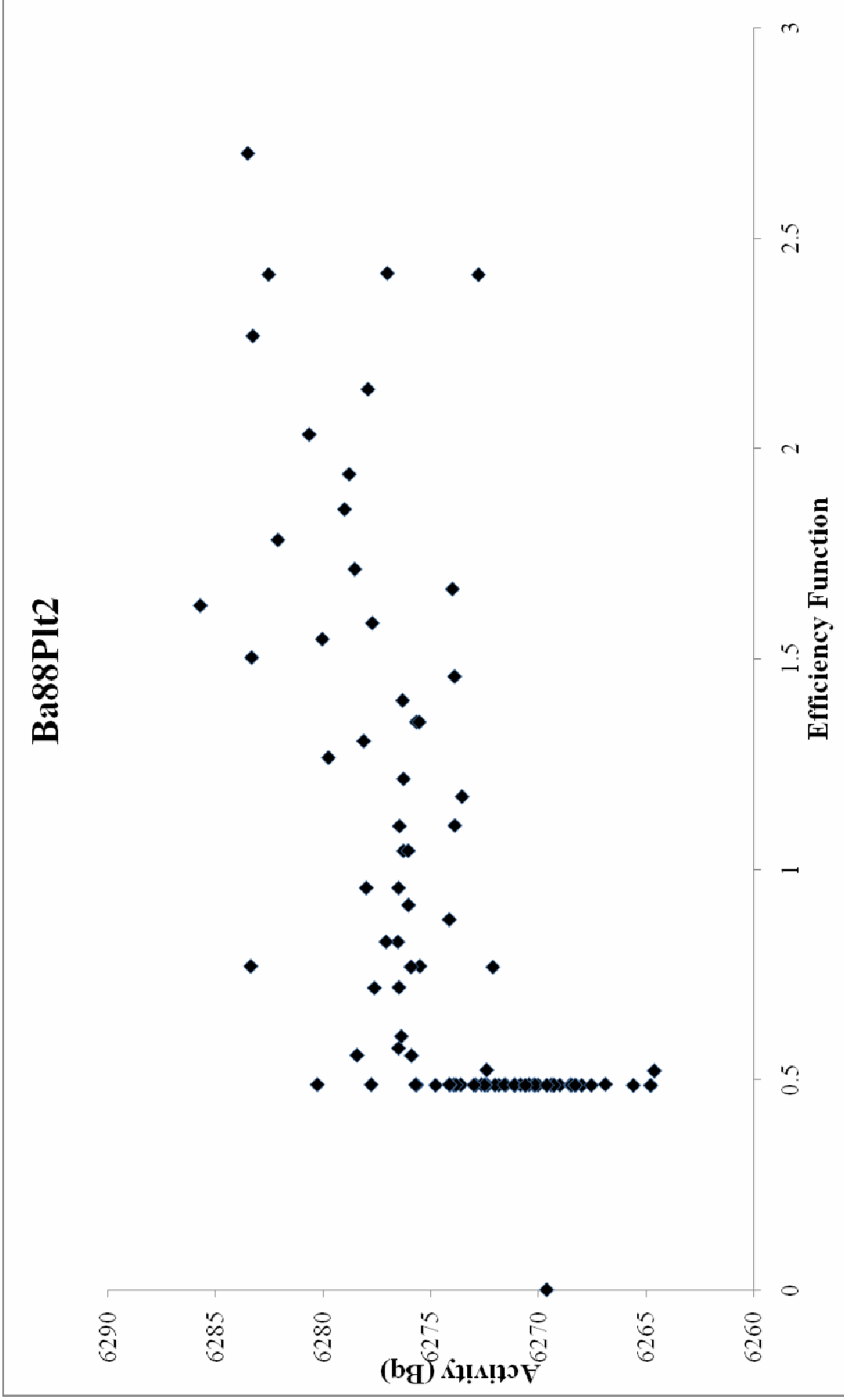

Figure 22. The Stanford Arbitrary Wave-form Composer lets β pulses through the Linear Gate during the “no-control-pulse” intervals.

The arrangement in Figure 22 is similar to that in Figure 21. The control pulse is again 1.766 μ s wide. There is a 5.592 μ s interval between pulses. Thus, Period (μ s) = 1.766 + 5.592 = 7.358.

Ba88P1t1





Ba88Pt3

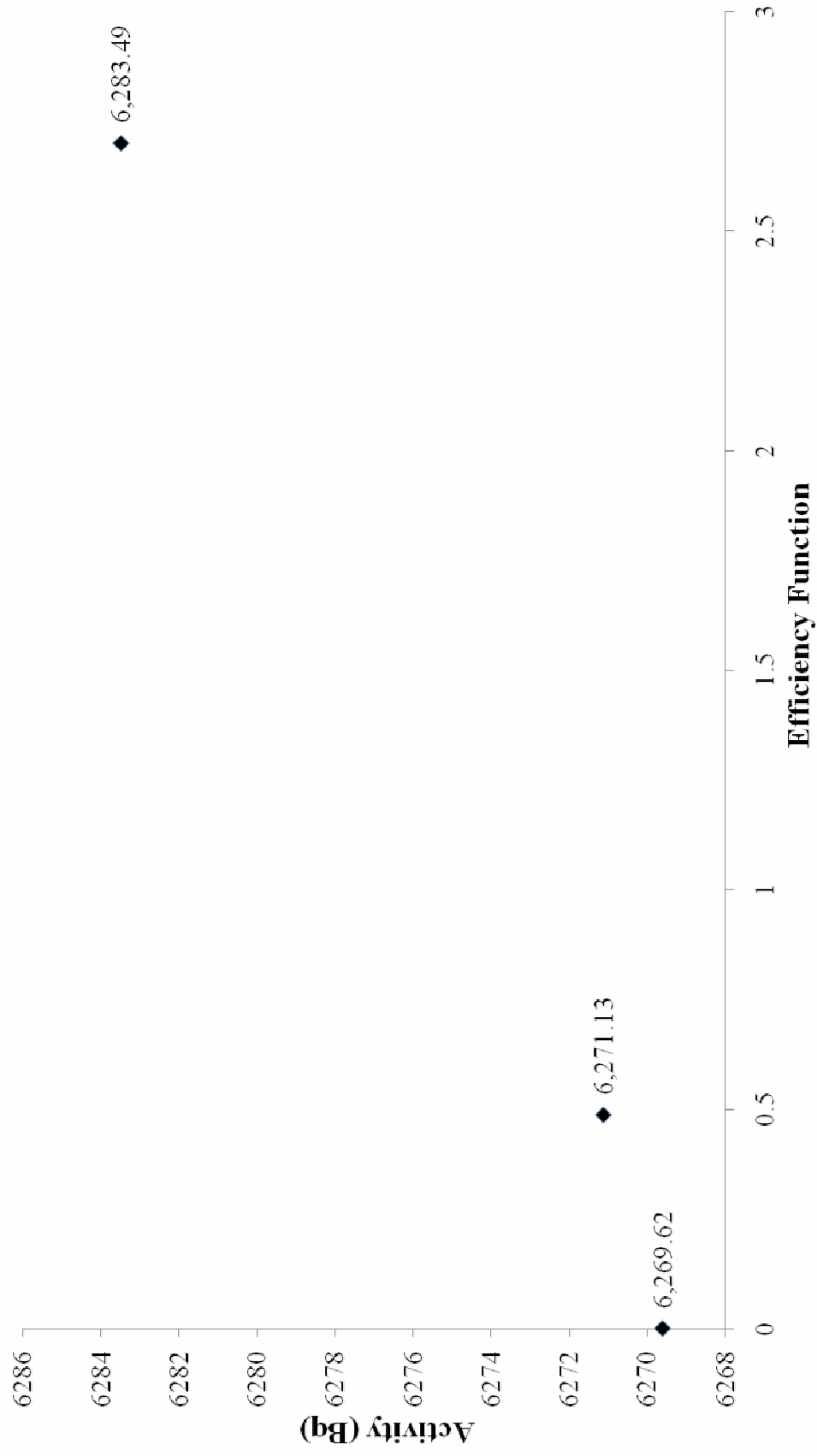

24. THE THREE GRAPHS OF ACTIVITY VERSUS EFFICIENCY FUNCTION

Activity is measured in Becquerel.

Efficiency Function = $(1 / \text{Efficiency}) - 1$.

The straight-line graph Ba88 Plt 1 is obtained by the method given in “Excel for Windows”. Let y denote Activity and x denote Efficiency Function. The Least-Squares line, $y = mx + b$, intersects the y axis at $(0,b)$, and the values of m and b are printed.

The graph Ba88 Plt 2 records the experimental points. The single point on the Activity axis is the intercept $(0,b)$ of the Least-Squares Line ($y = mx + b$). The program Ba88 Pts calculates (from the 88 experimental points) m , b and the coordinates of the centroid of the experimental points. The equation $y = mx + b$ is used to calculate the ordinate of the Least-Squares-Line point whose abscissa is 2.7 .

In the graph Ba88 Plt 3, the point on the Activity axis is the intercept $(0,b)$. The program Ba88 Dual calculates the coordinates of the centroid of the 44 experimental points in the vertical cluster in Ba88 Plt 2. This centroid is represented by the middle point in Ba88 Plt 3. The right-hand point in Ba88 Plt 3 is the Least-Squares-Line point whose abscissa is 2.7 .

25. REFERENCES

1. Bryant J., *Int. J. Appl. Radiat. Isot.*, 1963, **14**, 143-151.
2. Wyllie H.A., *Appl. Radiat. Isot. Vol. 38. No.5. pp. 385-389, 1987 Int. J. Radiat. Appl. Instrum. Part A*
3. Ratel G., *Nuclear Instruments and Methods in Physics Research A 316 (1992) 318-323 North-Holland*
4. Baerg A.P., *Metrologia*, pp. 131-133, 1965.