



AUSTRALIAN ATOMIC ENERGY COMMISSION
RESEARCH ESTABLISHMENT
LUCAS HEIGHTS

FLOW OF SPHERES AND NEAR SPHERES IN CYLINDRICAL VESSELS
PART IV
INDIVIDUAL FLOW PATHS IN RECIRCULATED RANDOM PACKINGS

by

F. C. GATT

December 1973

ISBN 0 642 99613 X

AUSTRALIAN ATOMIC ENERGY COMMISSION

RESEARCH ESTABLISHMENT

LUCAS HEIGHTS

FLOW OF SPHERES AND NEAR SPHERES IN CYLINDRICAL VESSELS
PART IV
INDIVIDUAL FLOW PATHS IN RECIRCULATED RANDOM PACKINGS

by

F.C. GATT

ABSTRACT

An experimental investigation was made of the transit of individual pebbles in recirculated random packings of equal spherical or aspherical pebbles. Pebbles of 1.0 inch or 0.75 inch nominal diameter and 3.0 or 3.4 specific gravity are used to form beds in a 30 inch diameter vessel with a concave base and single axial outlet. The pebbles flow downwards under the influence of gravity through a rotating extractor in the base. A radioactively tagged pebble is inserted at the top of the bed and as it descends with the pebble packing its position is detected and recorded at intervals using a tracking device. In this way tracks and velocities of pebbles seeded in the bed for various combinations of seeding radius, bed and pebble parameters are determined, and are found to be generally of 'streamline' form. The

extractor rotation has very little effect on the motion of the pebbles in the bed. Using the tracks of tagged pebbles, patterns and effects of flow zones are deduced. Transit numbers of tagged pebbles are found to be in good agreement with the results of similar experiments recorded in Part III of this report series.

National Library of Australia card number and ISBN 0 642 99605 9

The following descriptors have been selected from the INIS Thesaurus to describe the subject content of this report for information retrieval purposes. For further details please refer to IAEA-INIS-12 (INIS: Manual for Indexing) and IAEA-INIS-13 (INIS: Thesaurus) published in Vienna by the International Atomic Energy Agency.

CYLINDERS; DATA; FLOW MODELS; FUEL ASSEMBLIES; FUEL ELEMENTS; LABELLING; MOTION; PEBBLE BED REACTORS; REACTOR FUELLING; SHAPE; SIMULATION; SPHERES; ZONES

PREFACE

This report is part of a series on 'Flow of Spheres and Near Spheres in Cylindrical Vessels' as follows:

- Part I - Experiments with recirculated random packings using flow visualisation technique. G.A. Tingate, AAEC report in preparation.
- Part II - Pebble transit in recirculated random packings. F.C. Gatt, AAEC/E207.
- Part III - Transit spectra for recirculated random packings. F.C. Gatt, AAEC/E225.
- Part IV - Individual flow paths in recirculated random packings. F.C. Gatt, AAEC/E273 (this report).
- Part V - The effect of recirculation rate on pebble transit. M.E. Edwards, F.C. Gatt, G.A. Tingate, AAEC report in preparation.
- Part VI - Experiments with regular packings. G.A. Tingate, AAEC report in preparation.
- Part VII - Flow mechanisms in pebble beds. G.A. Tingate, AAEC report in preparation.
- Part VIII - Summary and conclusions. F.C. Gatt, G.A. Tingate, AAEC report in preparation.

CONTENTS

	Page
1. INTRODUCTION	1
1.1 Objectives	1
2. EQUIPMENT	1
2.1 Vessel	2
2.2 Pebbles	2
2.3 Vessel Loading Procedure	2
2.4 Pebble Packing	3
2.5 Entry Mechanism	3
2.6 Extractor and Conveyor	3
2.7 Tagged Pebbles	4
2.8 Pebble Tracker	5
2.9 Pebble Flowrate	5
3. EXPERIMENTAL PROCEDURE	6
3.1 Data Analysis	6
4. RESULTS AND DISCUSSION	7
4.1 Analysed Trials	7
4.2 Flow Zones	8
4.3 Pebble Velocity	11
4.4 Extractor Influence	12
4.5 Stream Tube Model	12
4.6 Wall Effect	12
4.7 Pebble Transit Numbers	13
5. CONCLUSIONS	14
6. ACKNOWLEDGEMENTS	15
7. REFERENCES	15

Table 1	Analysed Groups of Trials with Common Attributes
Table 2	Trial Attributes
Table 3	Groups of Trials with Common Attributes
Table 4	Inclination of the Dead Zone Boundary
Table 5	Trials with Effects in Radial, Angular, and Circumferential Velocities
Table 6	Maximum Pebble Velocities
Table 7	Influence of Extractor on Pebble Movement
Table 8	Trial Circumferential Velocities

CONTENTS (Cont'd.)

Table 9	Velocity Profile Difference
Table 10	Wall Centre Identical Geometry Pairs
Table 11	Pebble Transit Numbers
Figure 1	Pebble bed
Figure 2	Equipment for the pebble bed experiment
Figure 3	Extractor and base
Figure 4	Entry mechanism pebble scatter
Figure 5	Entry mechanism and tagged pebble seeding tubes
Figure 6	Photocell and pebble counter
Figure 7	Broken pebble sorter
Figure 8	Tagged pebble
Figure 9	Pebble tracking device
Figure 10	Detector heads
Figure 11	Experimental data flow
Figure 12-55	Paths of pebbles through pebble beds
Figure 56	Diagram of flow zones and flow patterns (after Deutsch 1967a)
Figure 57-64	Flow zones
Figure 65	Plot of resultant pebble velocity versus pebble axial position for trial number 363.
Figure 66	Plot of resultant pebble velocity versus pebble radial position for trial number 363.
Figure 67	Pebble extractors
Figure 68	Range of transit number spectral means for varying base angle and seeding radius.
Figure 69	Range of transit number spectral standard deviations for varying base angle and seeding radius
Figure 70-82	Transit number versus radial seeding position for groups 18, 22, 34, 35, 36, 37, 38, 39, 40, 41, 42, 43 and 44.
Appendix A	Notation
Appendix B	Paper Tape Code
Appendix C	Example of Tracker Printed Output
Appendix D	Program DC1 - Pebble Tracking Program
Appendix E	Block Diagram of Program DC1
Appendix F	Transformation of Co-ordinates from the Tracker System (θ_1, θ_2, Z) to the Cylindrical Co-ordinate System (r, θ, z)

CONTENTS (Cont'd.)

- Appendix G Pebble Velocities Calculation
Appendix H Limitations of Computer Plotting Subroutine

1. INTRODUCTION

In a pebble bed nuclear reactor, fuelled pebbles enter at the top of the reactor vessel and undergo a nuclear reaction producing heat. They pass through the bed and out through the base of the vessel via an extractor.

Important parameters are the pebble path and relative velocity through the bed; excessive time spent in parts of the bed could result in severe irradiation and thermal damage to the pebble with possible fission product escape. The extreme case would be the permanent fixation of a given pebble or group of pebbles in a region of the vessel. The feasibility of the recirculating pebble bed depends on the maintenance of satisfactory pebble flow through the vessel, its outlet and the pebble extractor.

In this experiment, which investigates pebble paths and velocities in the bed, the pebbles used simulate the reactor fuel elements in size, shape, surface and density. The levels of the pebble and bed parameters are selected to assure that data obtained are applicable to the reactor study.

1.1 Objectives

The objectives of the work are:

- (a) To determine the track of individual pebbles seeded in the bed for various combinations of bed and pebble parameters.
- (b) To determine the velocity of individual pebbles in the bed for various combinations of bed and pebble parameters.
- (c) To determine the effect of the various bed geometries and pebble parameters on flow zone shapes (Deutsch 1967a).
- (d) To determine pebble transit numbers of seeded pebbles in the vessel. The transit number of the pebble is defined (Gatt 1970) as the number of pebbles recirculated between the seeding of the pebble in the bed and its exit from the bed, expressed as a fraction of the bed inventory. The bed inventory is defined as the total number of pebbles in the pebble bed.
- (e) To determine the effect on pebbles of the extractor rotation.
- (f) To find the effect of the base angle and extractor diameter on the dead zone.
- (g) To find the bed height above which plug flow occurs.
- (h) To define the limits of the plug flow zone, the pipe feed zone, the dead zone and the pipe zone in terms of the bed parameters.

2. EQUIPMENT

An outline of the pebble bed is given in Figure 1 while Figure 2 shows the experimental equipment. The vessel is filled to the required height with

pebbles, thus forming the bed. A radioactively tagged pebble is inserted at the top of the bed and extraction and recirculation of the bed is commenced using the extractor and the conveyor. As the tagged pebble descends with the bed, its position is detected and recorded at intervals using the tracking device. When the tagged pebble emerges it is separated from the main stream and the experiment is stopped.

2.1 Vessel

The vessel is an upright aluminium cylinder with diameter 30 in. and height 60 in. A cone, in some cases a hexagon-faceted cone (concave as viewed from above), forms the base of the vessel. Throughout this report the different bases are henceforth referred to as either a conical or hexagonal base. The base is either slotted or unslotted with a base angle (measured from the horizontal) of 15° , 25° , 35° or 45° (see Figure 3). In the centre of the base is located an extractor in a single axial outlet tube of diameter 8 or 5 inches.

2.2 Pebbles

Four types of pebbles are press-formed from plastic (polyvinyl alcohol) bonded zirconite sand, after which they are cured to the desired hardness and plastic coated to provide wear resistance. The finished pebbles have the following properties:

Surface finish (projections)	± 0.001 in.
Sphericity	± 2 per cent
Diameter	1.0 ± 0.02 in.
	0.75 ± 0.02 in.
Specific gravity	3.0 ± 0.07
	3.40 ± 0.07

The value of the nominal pebble diameter (D_p) is used to specify the size of both spherical and aspherical pebbles (for notation see Appendix A). Aspherical pebbles are used to simulate worn spherical fuel elements. In effect two sizes of aspherical pebble are produced by removing from each spherical pebble a slab of thickness $0.10 D_p$ centred on the pebble equator, and then joining the identical halves. The resulting pebble has an equatorial diameter of $0.999 D_p$ and a length through the poles of $0.90 D_p$. Dimensions and sphericity of the segments are held to the above tolerances.

2.3 Vessel Loading Procedure

The procedure follows that recommended by Leesment (1965a). The vessel is filled by loading the pebbles into a cylindrical hopper fitted with a trapdoor in its base. The hopper is lowered into the vessel and the trapdoor

is released, allowing the pebbles to flow into the vessel. The hopper is then raised slowly to minimise impact velocity. This method of loading is designed to give a random and relatively loose packing. Leesment (1965b) shows that the effect of the method of packing in this case was to obtain a void fraction of between 0.401 and 0.404.

2.4 Pebble Packing

The packing of identical pebbles was made up of the following sections as shown in Figure 1:

- (i) The base section, which extends from the vertex of the vessel base to the top or widest part of the conical or hexagonal base of the vessel.
- (ii) The cylindrical section, which extends from the top of the vessel base to the top of the cylindrical section of the bed. The length of this cylindrical section at the start of recirculation is termed the pebble bed height (H).
- (iii) A top conical section of pebbles extending from the top of the cylindrical section to the apex of the cone of pebbles formed when pebbles are dropped down the axial centre of the vessel onto the cylindrical section.

2.5 Entry Mechanism

The variation of scatter of pebbles using the entry mechanism (Leesment and Stephenson 1964) is shown in Figure 4. The mechanism (Figure 5) is designed to ensure, as far as possible, an even distribution of pebbles over the bed, that the pebble entry is central and vertical and that the pebbles possess negligible velocity. Unevenness of the scatter would result in a shift in the apex of the top section of the bed with a resulting nonuniformity of pebble bed height around the vessel wall. A baffle plate below the entry mechanism is used to reduce vertical pebble velocity to a minimum before hitting the top surface of the pebble packing. The pebble drop height to the surface of the pebble packing can be varied from 0 to 8 in.

2.6 Extractor and Conveyor

The extraction mechanism used in the rig evolved from much development work. Four of the original mechanisms are discussed by Rollinson (1963). The extractor concept used in this work consists of a raised cylindrical centre surrounded by a trough into which pebbles to be extracted align themselves. The extractor rotates while the pebbles are held almost stationary by the weight of the pebble packing above. When the elongated hole passes beneath a pebble, that particular pebble falls into the rotating pipe attached to the

extractor and rolls out of the vessel.

The extraction devices permit pebbles to escape at controlled rates, one at a time, rolling singly from the vessel and extractor outlet into a channel. When passing along the channel, the pebbles are counted automatically with a photoelectric counter (Figure 6) and then roll down a runway consisting of two round bars, as shown in Figure 7. This acts as a broken pebble sorter enabling parts of broken pebbles to fall through or stop on the gently sloping runway. After counting, the pebbles are elevated to the top of the bed to the intake of the unshielded endless bucket conveyor. From the conveyor, they roll down another channel to the entry at the centre of the vessel top cover and then into the vessel (Figure 2).

The extraction mechanism is situated at the vertex of the vessel base (high position), or in some cases 12 in. below the vertex of the vessel base (low position), in a single axial outlet tube (Figure 3). The purpose of the extended extractor is to simulate as far as possible its remote placing in a vessel fuelled with nuclear material. The remoteness is meant to reduce the nuclear radiation level over the extractor during operation and maintenance.

2.7 Tagged Pebbles

Throughout each trial a tagged pebble of the same sphericity, diameter, specific gravity and surface finish as those constituting the pebble bed is used. A typical tagged pebble is shown sectionally in Figure 8. It has a small hole drilled to allow insertion of a radioactive cobalt-60 source. After insertion of the source a close fitting zirconite plug is fitted and glued flush with the pebble surface. The plug has a convex end so as to continue the outer spherical surface of the pebble.

The cobalt-60 source emits gamma rays which can be monitored, thus enabling the position of the tagged pebble in the bed to be determined. To achieve satisfactory tracking of the tagged pebble, the activity of the cobalt-60 sources used must be varied to allow for the effect of shielding by the bed during their movement through the vessel. Maximum activity required is approximately 0.5 curie for the pebble moving through the centre of the vessel. On completion of each trial the tagged pebble is separated from the main stream by the special separator gate actuated by the gamma rays from the cobalt-60 source (with a second actuator and gate provided for safety) and placed in a lead-shielded flask. The flask is lifted by a crane which is used to place it in position over the required insertion tube. The pebble is then released through a remotely operated door and falls into place in the tube which reaches just below (1-2 pebble diameters) the top level of

the pebbles in the vessel. Leesment and Stephenson (1964) have noticed that most pebbles seeded on the top surface of the cone appear to move radially before moving downward towards the outlet. The tube thus ensures radial location at the start of the trial.

2.8 Pebble Tracker

Movement of the tagged pebble, seeded at the different radial positions, is followed by a tracking device (Figure 9). It uses pairs of collimated radiation detectors (Figure 10) placed outside the vessel to obtain the position of the tagged pebble. Three pairs of detectors are mounted on a platform whose height may be varied. First, the centre pair (axial detector), is used to establish the vertical position of the tagged pebble, and then the outer pairs (theta 1 and theta 2) rotate until both are aligned with it. Its location is then defined by the height of the platform and the angular position of the outer detectors.

The equipment (Geeson 1965) is designed to locate the tagged pebble in successive positions automatically (e.g. at given time intervals), display the results and record them on paper tape for computer processing. The method of handling the information from the tracker (on paper tape) is given in Figure 11. The paper tape code used is given in Appendix B.

One of the forms of raw data from the tracker is printed paper tape (Appendix C). When a trial is begun, the equipment prints a heading record, the first three numbers identifying the trial sequentially and the following five being the date. The next record (data record) is comprised of five numbers: the first, of six digits, is the time in seconds of the 'fix' on the pebble; the second three-digit number is the theta 1 detector position reading in volts; the third three-digit number is the axial co-ordinate in volts; the fourth three-digit number is theta 2 in volts; and finally, the tracking mode (one pebble in the bed at any one time) is always unity, '1'.

2.9 Pebble Flowrate

The pebble flowrate throughout the experiment has a variation of ± 125 pebbles per minute, (228 to 478 pebbles per minute). These variations have very little effect on the transit number (Gatt 1970). In addition Edwards (ca. 1965) has found that a variation in flowrate of from 0.5 to 380 pebbles per minute has no noticeable effect on the flow profile.

The pebble flowrate is repeatedly checked throughout the experiment by using a five minute impulse counter connected to the photoelectric cell pebble counter. In this way, the pebbles being extracted are tallied during

any five minute period to obtain the pebble flowrate which is then recorded.

3. EXPERIMENTAL PROCEDURE

The pebble bed is filled with unmarked identical pebbles to the required bed height, H. The top cone of pebbles is manually formed thereby simulating the mound of pebbles which forms naturally during recirculation.

The tagged pebble is introduced through the insertion tube to a point just below the level of the top cone surface, at the desired seeding radius. Recirculation of the bed, and location and tracking of the tagged pebble is then started. The number of pebbles in transit between the extractor and reinsertion at the top of the bed does not exceed 400, which is negligible in comparison with a typical inventory of 30,000 pebbles. The transit number of each tagged pebble is noted at the moment of its extraction.

3.1 Data Analysis

An outline of the experimental data flow is given in Figure 11. The temporal and positional data from the pebble tracker is in the form of five-channel (5 hole) paper tape. This tape is read and edited for 'out of format' punching by the computer which also initialises each record from the paper tape with two characters to indicate whether the record is data, heading, error or other. The records are then fed to a magnetic tape for storage while also being reproduced in printed form (to serve as a check with the pebble tracker printed output). The records on the magnetic tape are analysed using the program DC1 (Appendix D; also see block diagram in Appendix E), the purposes of which are to transform the co-ordinates from the tracker system to the cylindrical co-ordinate (vessel) system (Appendix F) and to calculate pebble velocities (Appendix G). The results are reproduced graphically using a computer plotting subroutine cited in Rodwell (1965). The limitations of this plotting technique are discussed in Appendix H.

It is stressed that in the program DC1 the elapsed time of a trial is taken from the punched paper tape record of the trial. During the trial an average pebble recirculation rate is taken by counting the number of pebbles recirculated at intervals during a period of five minutes. In the program DC1 this average pebble recirculation rate is multiplied by the elapsed time to arrive at an elapsed 'time' not in minutes but in pebbles recirculated. Also, the total number of pebbles recirculated during the trial is taken from the photoelectric counter on the rig.

Of all the trial data put onto paper tape a total of 156 trials out of 204 trials (or 76%) are readable by the computer, the other trials being either damaged, mispunched or misnumbered by the paper tape punch attached to

the pebble tracker. Those trials which are analysed are listed with their attributes in groups in Table 1.

In the analysis of the pebble motion, the pebble velocity is presented as five velocities, that is, axial, radial, angular, circular and resultant. These velocities are given for each trial at particular intervals of the pebble's motion through the bed. The units for these velocities are, axial: inches per minute, radial: inches per minute, angular: degrees per minute, circumferential: inches per minute, resultant: inches per minute, although pebble motion can also be expressed as centimetres or inches per pebble recirculated (Leesment 1964).

4. RESULTS AND DISCUSSION

4.1 Analysed Trials

A total of 204 separate trials were completed. A list of all trials together with each trial's attributes is given in Table 2. Table 3 shows these trials separated into groups having common trial attributes. Excluding pebble drop height, recirculation rate and bed inventory, there are 53 different groups or combinations of pebble and bed configurations used; however, after sifting out those trials unable to be processed by the computer, the number of groups has been reduced to 44. Table 1 lists these 156 trials in 44 groups and separates them into three classifications: A signifies single seeding position trial groups, B, the trials with seedings both in centre and wall positions and C, those trials seeded across the radius. The plots for all of these trials (Figures 12 to 55) show the projection onto one vertical plane across a bed radius of the axial and radial components of the tracks of the pebble. The rotational (or angular, circumferential) component is not taken into account for this part of the work. Further, the scale of the axes of the tracks are not exactly equal due to the limitations of the plotting program used. The actual scales used are 0.162 in. = 1 in. for the x axis and 0.166 in. = 1 in. for the y axis. The number at the top of each plot is the trial number.

Since the C type classifications are most interesting from the point of view of transit patterns through the bed, they are taken first; the plots are given in Figures 12 to 26 inclusive. All of these trials show that the motion of the pebbles down through the pebble bed is streamlined. After a period of time spent descending the bed in a vertical direction (relatively slow velocity near the top of the bed), the pebbles approach the vessel base and begin to move uniformly into the centre of the pebble bed (relatively fast velocity near the extractor).

As the pebble velocity increases, the magnitude of the time spent within the boundary of each plotted point decreases (shown by the smaller magnitude of the number allotted to each point). When the number assigned to each point reaches 1 (or .) and the velocity is still increasing, the distance between each point increases since, in this instance, the time between each plotted point is generally constant. The numbers on the track are strictly relative to that particular track only; however, approximate comparisons may be drawn between tracks. For further explanation of the numbers on the tracks see Appendix H.

Although Leesment and Stephenson (1964) state that there exists a definite time lapse before pebbles falling into the bed top surface sink into the surface and begin to move down with the packing, this is not shown in the pebble tracks since the tagged pebble is seeded into the bed top conical section and not just onto the surface of the packing.

The tracks for classifications A and B are given in Figures 27 to 55 inclusive. Note that in these plots the bed centre is represented by the vertical axis. Examination of these plots show that all pebbles follow fairly straight paths down the cylindrical section of the bed with very little interference or crossing between pebble paths. Then at or near the base section the pebble paths curve in fairly uniformly towards the outlet, again with very little mixing. Much the same conclusions may be drawn about the tracks of the pebbles seeded in these groups as those in classification C. Some of the pebbles seeded at the wall tend to move radially inward as they descend down the bed.

4.2 Flow Zones

Deutsch (1967a) divides the flow patterns occurring during discharge into the four zones, namely pipe, pipe feed, dead and plug flow zones, shown in Figure 56.

As the name implies, the pebbles within the dead zone move extremely slowly or not at all.

The plug flow zone is above the influence of the extractor. The velocity profile within this zone is uniform except for a boundary layer effect. The pebbles within the plug flow zone move as a solid mass. Pebbles entering the pipe feed zone gain a radial velocity component towards the centre and feed the pipe.

All pebbles leave the vessel via the pipe zone. This is a region in which the velocity is relatively high and sensibly vertical. Continuity requires the velocities to be high.

Deutsch (1967b) also states that the flow patterns during discharge are very different from the streamline flow of fluids through an orifice. Also, the angle of repose and the dead zone angle are related to the inherent friction angle of the pebbles and the friction developed between the vessel wall and the pebbles. Deutsch suggests that the flow in granular materials cannot be analysed by employing techniques of fluid mechanics, i.e. employing the analogy of stream tubes given by Brown (1961), Roberts (1967) and Bedenig, Von de Decken and Rausch (1967) .

An attempt is made to ascertain flow zones through which the pebble tracks pass. An average is taken of the flow zone shapes for each of the eight bed configurations (i.e. four base angles and two extractor diameters). The shapes, derived largely from Figures 12 to 26, are given in Figures 57 to 64 inclusive. In some instances the shapes are incomplete because of insufficient data in the pebble tracks. The results tend to confirm that the pebble motion directions can be grouped into zones such as Deutsch has suggested. Furthermore, the change from a 5 in. to an 8 in. diameter outlet tends to increase the volume of the pipe feed zone and to raise its upper limit, especially near the vessel wall. The diagrams also show that the smaller the base cone angle then the larger is the dead zone.

From examination of Figures 57 to 64 an estimate may be made of the extent of the dead zone. In the case of the 15° and 25° base angles the extent of the dead zone is similar. However, for 35° and 45° the dead zone rise up the cylindrical section is only approximately half that of the 15° and 25° base angle dead zones. The actual measurements are 15° : 6.5 in. to 7.5 in., 25° : 6 in., 35° : 3.5 in. to 5 in., 45° : 4 in. to 4.5 in. The measurements refer to the maximum extent of the dead zone from the base of the cylindrical section upwards. It is of interest to note that even though the base angle increases to 45° , the dead zone does not entirely disappear.

Deutsch (1967b) maintains that the inclination of the dead zone boundary to the horizontal is, in all cases, approximately twice the angle of repose. This is not borne out exactly in the outline of the flow zones deduced from experimental results; however, the inclination of the dead zone certainly increases as the base angle increases. The actual inclinations are given in Table 4.

To determine the inward extent of the dead zone in a randomly packed bed of pebbles, the following experiment is performed. A vessel with a 15° base is taken and, after filling the base with 0.75 in. spherical pebbles, a tagged pebble is placed at the junction of base and cylinder. The vessel is

filled to 30 in. and location of the tagged pebble, tracking and recirculation is begun. After a recirculation of 250,000 pebbles the tagged pebble had not moved from its original position. A similar trial is performed with the tagged pebble placed in the cylinder two pebble diameters in and two pebble diameters up. After 250,000 pebbles were recirculated no movement had occurred. Again, in a third position three pebble diameters in and three pebble diameters up in the cylinder, after recirculation of 200,000 pebbles the tagged pebble had again not moved. Shortly after this the pebble began to move slowly and intermittently and finally emerged after 508,000 pebbles had been recirculated. The conclusion reached here is that if a pebble does become lodged in the dead zone of the pebble bed it could stay there indefinitely, since very little or no motion occurs at the vessel boundary of the dead zone.

In all the trials tested, several tracks appear to move through or graze the edge of the dead zone. These trials are all seeded at or close to the wall, and in the dead zone region the magnitude of the resultant velocity is quite small (0.2 in. per minute compared with a maximum resultant pebble velocity of 37.8 in. per minute). In general, pebbles passing through the bed close to the dead zone all exhibit low resultant velocities.

The plug flow in the vessel appears to begin to break up at a height of 15 in. ($D/2$) from the vessel base. This conflicts with the results of Denton (1953) who found that a transition from plug to pipe feed zone occurs at a height equal to one quarter of the diameter of the vessel when using a 45° base angle. Leesment (1964) finds that the transition from plug flow to pipe feed flow (base angle unstated) occurs with rough particles (beach sand) at a height of $2D$ to $3D$, while with spherical particles (glass beads) it occurs at $1D$ to $2D$. The reason for the discrepancies probably lies in the differing frictional coefficients of the pebbles used by Denton, Leesment and the author of this report.

Using Figures 57 to 64 an estimate is made of the extremity of the plug flow zone:

Base angle (degrees)	15	25	35	45
Lower end of plug flow zone (in.)	11-20	7-11	4-9	6-9

The distance indicated is measured from the base of the cylindrical section. It is seen that as the base angle increases the variation in the lower end of the plug flow zone diminishes and the actual lower end position of the plug flow zone is nearer to the base of the cylindrical section.

A trend which is apparent in the shape of the flow zones when the base angle is changed shows that both the pipe zone and the dead zone increase in

size and move their upper limits further up into the vessel as the base angle decreases. This has the effect of not only decreasing the transit number of a pebble seeded in the centre of the bed, but also of increasing the transit number of a pebble seeded at or near the wall of the vessel.

An attempt was made to distinguish a trend in the shape and size of flow zones induced by changes in pebble parameters (listed in Gatt 1972). However, the data available was insufficient to reach any real conclusion on these effects.

4.3 Pebble Velocity

At a constant recirculation rate in a fixed geometry bed the downward velocity of the pebble varies with its axial and radial position (Leesment and Stephenson 1964).

An examination of the radial, angular and circumferential velocities shows that generally the velocity of the pebble is zero throughout the transit (see Table 5). As can be seen from the table, a total of 5 or 3% of trials (all near the bed centre) exhibit nil movement (for those instances chosen by the computer) in the above three directions, while 37 per cent of the trials show movement only towards the end of the transit, implying that the reason for movement in the above three directions is due to the presence of the conical or hexagonal base of the vessel. Sixty per cent of the trials show intermittent movement throughout the whole of the transit. This indicates that in many cases the resultant velocity of the pebble is merely the axial (or downward) velocity.

Table 6 shows a list of the maximum axial and resultant velocities for each trial and where each maximum occurs (in relation to the pebble bed height). Generally resultant velocities are small at the top cone and cylindrical section and increase sharply towards the base section. Of the maximum axial velocities, 84% occur within a distance of 10 in. from the base of the cylindrical section while 91% of the maximum resultant velocities occur in this portion of the bed. A typical plot of resultant pebble velocity versus the axial height of the pebble in the bed is shown for trial number 363 in Figure 65. The resultant pebble velocity versus the radial position of the pebble in the bed is shown also for trial number 363 in Figure 66. Here a similar situation appears to exist; as the pebble nears the centre of the pebble bed the pebble resultant velocity increases.

In effect we have the resultant pebble velocity increasing as the pebble descends in the pebble bed and to a much smaller extent as the pebble moves into the centre of the pebble bed, indicating the higher velocity regions of

the pipe feed and pipe zones.

4.4 Extractor Influence

Bed rotation up to $8-10 D_p$ high from the extractor is caused by a star wheel extractor used initially in some extractor development experiments (Leesment and Stephenson 1964). However, bed rotation with a single hole extractor (Figure 67) is appreciably less than that of a star wheel.

The influence of extractor rotation on the flow of pebbles may be found by examination of the circumferential component of the pebble velocity in the region of the extractor. Influence of the rotation of the extractor cannot readily be derived from consideration of the change in angular position of the pebble in the bed, since near the bed centre angular position can change very quickly and over a wide range due merely to the lateral change in position as the pebble moves down the bed. So in the analysis of data the circumferential velocity is tabulated for all trials in Table 7. However, there is very little difference in the magnitude of the circumferential velocity in either case. For example, there are no instances of nil effect in the high position extractor cases, but there are five instances of nil effect in the low position extractor cases. The fraction of the total number of trials having circumferential velocities in each velocity range is given in Table 8; however, no obvious sign of the effect of the extractor position on the magnitude of circumferential velocity can be seen. What can be seen is that the circumferential velocities for most trials lie within the range 1 to 10 in. per minute (10^0 to 10^{+1}).

4.5 Stream Tube Model

Bedenig, von de Decken and Rausch (1967) propose a stream tube model for calculating pebble bed flow. The flow is supposed to be laminar and the core is divided into 'concentrical ring volumina', the stream tubes being given by paths of motion of the spheres. Within every stream tube the mass flow is constant because of the law of continuity for incompressible media. The velocity at any point in the stream can then be calculated if the residence time is known. Use can be made of the stream tube model with the knowledge of sphere paths presented in this report.

4.6 Wall Effect

Wall effect measured in terms of local voidage extends to about 5 pebble diameters from the vessel wall. The annular region moves more slowly than the central part of the bed (Leesment 1964).

A possible method of determining the difference in velocity profile between the pebble seeded at the wall and one seeded in from the wall is to

compare the transit numbers of the respective trials. Those trials which can be compared and analysed are shown together with their transit numbers in Table 9. All pairs except two show an increase in transit number from the inner seeding position to the wall seeding position. This inner seeding position is nine inches in one case, as the adjacent seeding position trial is not available. The two exceptions to this decrease are trial numbers 23, 24 and 27, 28 which show a fractional decrease in transit number of 0.18 and 0.06 respectively. The plots for these trials can be seen in Figures 41 and 42 but, as they are relatively incomplete plots, the results of these pairs cannot be regarded as conclusive, and it can be assumed that there is a general increase in transit number as the pebble seeding position approaches the wall.

In Table 10 there is evidence to suggest that, in some cases, there is a widely differing elapsed time for pebbles to exit the bed when seeded at either the wall or the centre seeding positions in identical pebble and vessel geometries. This table shows the identical pairs of trials with their pertinent attributes and the times taken for the pebbles to traverse the bed. The times are also broken down to indicate the time down the cylindrical section as well as the time in the base section. No times are taken for the top cone as the pebbles are seeded through seeding tubes which extend through the top cone allowing the pebbles to emerge from the seeding tubes near the top of the cylindrical section.

A report by Lawther (1968) states that a problem encountered as fuel elements pass through the pebble bed core is the 'crystallisation' or 'aging' effect in which the formation of regular packings in layers near the wall increases during the initial recirculation of the bed. This increases the residence time for spheres near the wall to such an extent that it can exceed the fuel lifetime. The work at Arbeitversuchs Reaktor (AVR) Germany (Alder 1964) suggests that for spherical pebbles and a large D/D_p ratio, recirculation of the bed increases the extent of regularity of packing to eight to nine pebble diameters in from the solid boundary. This factor could be the cause of the excessive time spent by trial numbers 30, 46, 69, 88, 317 and 361 (Table 10) in traversing the bed. Another factor could be that in these instances the tagged pebble passes close to or through the dead zone.

4.7 Pebble Transit Numbers

The pebble transit numbers for all trials are calculated and listed in Table 11. Some of these transit numbers are in good agreement with those of the spectral transit numbers as found experimentally by Gatt (1972). In this context the range of transit number spectral mean and standard deviations are

reproduced here in Figures 68 and 69. In those instances where the trial attributes can be matched to the attributes of the trials contributing to the results in Figures 68 and 69, a total of 76% (or 87 out of 114) of the transit numbers agree to within \pm one standard deviation.

The transit numbers across the seeding radius for group numbers 18, 22, 34, 35, 36, 37, 38, 39, 40, 41, 42, 43 and 44 are shown in Figures 70 to 82 inclusive. These transit number spectra show reasonable agreement with the spectra as shown in Figures 68 and 69. These spectra generally show the increase in transit number as the seeding position changes from the centre of the bed to the wall.

5. CONCLUSIONS

The paths of pebbles through the pebble bed are generally streamlined. The motion of individual pebbles is intermittent with frequent local lateral changes in direction. These changes generally constitute a lateral shift in the streamline path of the pebble (or a 'joggle' in the path). However, such local changes do not adversely influence the general streamline flow pattern but appear to serve as a mechanism for changing the pebble flow direction towards the extractor. Even though these lateral changes in direction are present in the paths of individual pebbles there occurs very little interference or crossing between pebble paths.

Resultant pebble velocities are small near the top cone but increase sharply towards the base section and also (but not as markedly) towards the centre of the bed. However there is no noticeable rotational component of the resultant velocity in the vicinity of the rotating extractor, indicating very little or no effect of the extractor on pebble motion.

During descent through the bed the pebbles seeded at or near the wall tend to move in towards the centre of the bed thus avoiding the very slow moving dead zone. This inward movement appears to begin anywhere throughout the height of the cylindrical section.

The general boundaries or limits of the four pebble bed zones are shown to be in accordance with previous literature and all zones exist for each base angle tested. It can be observed that the limits of the zones are defined by the paths and velocities of the pebbles through the bed. An increase in extractor diameter tends to increase the size of the pipe feed zone.

A major factor in extending the time spent by a pebble in the bed comes into play when the pebble grazes or passes through the dead zone. A similar effect could be caused by regions of 'crystallisation' obstructing the pebble

in its path near the vessel wall.

Parts of the dead zone formed by a 15° base appear to be permanently fixed, not moving at all as recirculation progresses. However, as the base angle increases the effect of the dead zone on pebble flow decreases allowing the transit number of pebbles seeded near the wall to be closer in magnitude to the transit number of pebbles seeded towards the centre of the pebble packing. Also, as the base angle increases the inclination of the dead zone increases. If the base angle is increased to 45° the dead zone still exists and affects pebble flow.

As the base angle is decreased to 15° the dead zone size increases, the size of the pipe zone decreases, and both move further up into the vessel which has the effect of decreasing the transit number of pebbles seeded near the vessel centre and increasing the transit number of pebbles seeded near the vessel wall.

The plug flow zone extends down into the pebble packing to a height of 4 to 20 in. above the vessel base (the base of the cylindrical section) depending on the base angle.

The transit numbers of the individual trials are in strong agreement with statistics experimentally produced with packed beds in previous work.

6. ACKNOWLEDGEMENTS

The author thanks Mr. Michael Hunt who spent a great amount of time and effort in developing the rig and tracking system, and Mr. Peter Wydeveld and Mr. Neville Ridgway who devised an efficient computer program for interpreting the raw tracking data (on punched paper tape) and analysing this data. Thanks are also due to Messrs. G.W.K. Ford, E. Szomanski, G. Tingate, F.A. Rocke and G. Saiva for their helpful advice and suggestions, and also to Messrs. N. Hargreaves, R. Gumbleton, K. Sweetman, J. Giger, E. Longmore and D. Williams for experimental work.

7. REFERENCES

- Alder, K.F. (1964) - Report on Overseas Visits, August to October 1964.
AAEC/TM275.
- Bedenig, D., Von de Decken, C.B., Rausch, W. (1967) - Investigations on the movement of spheres in a pebble bed reactor. Brown Boveri/Krupp Reaktorbau G mb H. Paper No. 1.1 presented at Symp. on Movement of Gran. Mat. and Struct., Fluid Flow and Heat Transfer in Packed Beds. Held at AAECRE Lucas Heights, 16th February.
- Brown, R.L. (1961) - 'Note', Nature (London), 191 (4787) 458-461.
- Denton, W.H. (1953) - The packing and flow of spheres. AERE E/R 1095.

- Deutsch, G.P. (1967a) - Flow of granular material from silos - Paper No.3.3 presented at Symposium on Movement of Gran. Mat. and Struct., Fluid Flow and Heat Transfer in Packed Beds. Held at AAECRE Lucas Heights, 16th February.
- Deutsch, G.P. (1967b) - Investigation of flow mechanism of balls in a container. Department Report No.14, Department of Civil Engineering, University of Melbourne.
- Edwards, M. (ca. 1965) - Experimental work on effect on transit number of variations in pebble extraction rate. AAEC unpublished report.
- Gatt, F.C. (1970) - Flow of spheres and near spheres in cylindrical vessels, Part II - Pebble transit in recirculated random packings. AAEC/E207.
- Gatt, F.C. (1972) - Flow of spheres and near spheres in cylindrical vessels, Part III - Transit spectra for recirculated random packings. AAEC/E225.
- Geeson, C.T. (1965) - Scanner control unit. AAEC unpublished report.
- Lawther, K.R. (1968) - Private communication on Symposium on Problems of the Pebble Bed and Granular Materials at Julich, W. Germany, 6-7 March.
- Leesment, H.H. (1964) - Design of ball flow visualization experiments. AAEC unpublished report.
- Leesment, H.H. (1965a) - Basic mechanics of pebble flow - literature survey. AAEC unpublished report.
- Leesment, H.H. (1965b) - A note on voidage in pebble beds. AAEC unpublished report.
- Leesment, H.H. and Stephenson, L.P. (1964) - Design and preliminary results of PBR Ball Flow Rig. AAEC unpublished report.
- Roberts, A.W. (1967) - The dynamics of granular material flow through curved chutes, Applied Mechanics Conference, Inst. of Engineers. Held in Adelaide, 1-2 June. Mech. Chem. Eng. Trans. MC3 (2) 216.
- Rodwell, J. (ed.) (1965) - 7040 subroutines currently available from reactor physics. AAEC unpublished report.
- Rollinson, E.L. (1963) - HTGC Pebble Bed Reactor. Feasibility study of fuel handling systems. Part I - Fuel discharge. AAEC unpublished report.
- Szomanski, E. (1967) - The AAEC's main pebble bed reactor engineering experiment. Mech. Chem. Eng. Trans. MC3 (1) 40.
- The Institution of Engineers, Australia (1965) - A novel tracking device. J. Inst. Eng. Aust. 37 (10-11) 381.

TABLE 1

ANALYSED GROUPS OF TRIALS WITH COMMON ATTRIBUTES

CLASS	PEBBLE DIAM (IN.)	PEBBLE GRAVITY	PEBBLE BED SPECIFIC HEIGHT (IN.)			EXTR POS	BASE SHAPE	PEBBLE SEEDING RADIUS (IN.)
			PEBBLE DROPS HEIGHT (IN.)	EXTR DIAM (IN.)	BASE ANGLE (DEG)			
GROUP NO.	TRIAL NO.	PEBBLE SHAPE	PEBBLE DROPS HEIGHT (IN.)	EXTR DIAM (IN.)	BASE ANGLE (DEG)	BASE SURFACE		
I	I	I	I	I	I	I	I	
I	I	I	I	I	I	I	I	
1	B							
	10	1.00	SPH	3.4	6 28 8	LOW 35	CON NSLOT 0.0	
	11	1.00	SPH	3.4	6 28 8	LOW 35	CON NSLOT 14.5	
	12	1.00	SPH	3.4	6 28 8	LOW 35	CON NSLOT 13.5	
2	B							
	16	1.00	SPH	3.4	6 28 8	LOW 15	CON NSLOT 0.0	
	17	1.00	SPH	3.4	6 28 8	LOW 15	CON NSLOT 13.5	
	18	1.00	SPH	3.4	6 28 8	LOW 15	CON NSLOT 13.5	
3	B							
	20	1.00	SPH	3.4	6 28 8	LOW 25	HEX NSLOT 0.0	
	21	1.00	SPH	3.4	6 28 8	LOW 25	HEX NSLOT 13.5	
	22	1.00	SPH	3.4	6 28 8	LOW 25	HEX NSLOT 14.5	
4	B							
	23	1.00	SPH	3.4	6 28 8	LOW 35	HEX NSLOT 14.5	
	24	1.00	SPH	3.4	6 28 8	LOW 35	HEX NSLOT 13.5	
	25	1.00	SPH	3.4	6 28 8	LOW 35	HEX NSLOT 0.0	
5	B							
	26	1.00	SPH	3.4	6 28 8	LOW 45	HEX NSLOT 0.0	
	27	1.00	SPH	3.4	6 28 8	LOW 45	HEX NSLOT 14.5	
	28	1.00	SPH	3.4	6 28 8	LOW 45	HEX NSLOT 13.5	
6	B							
	29	1.00	SPH	3.4	6 28 5	LOW 25	CON NSLOT 0.0	
	30	1.00	SPH	3.4	6 28 5	LOW 25	CON NSLOT 14.5	
7	B							
	31	1.00	SPH	3.4	6 28 5	LOW 35	HEX NSLOT 0.0	
	32	1.00	SPH	3.4	6 28 5	LOW 35	HEX NSLOT 14.5	
8	B							

TABLE 1 (Cont'd.)

	33	1.00	SPH	3.4	6	28	5	LOW	45	CON	NSLOT	0.0
	34	1.00	SPH	3.4	6	28	5	LOW	45	CON	NSLOT	14.5
9	A											
	35	1.00	SPH	3.4	6	28	5	LOW	15	HEX	NSLOT	0.0
10	A											
	38	1.00	SPH	3.4	6	28	8	HI	45	CON	NSLOT	14.5
11	B											
	41	1.00	SPH	3.4	6	28	8	HI	35	HEX	NSLOT	14.5
	42	1.00	SPH	3.4	6	28	8	HI	35	HEX	NSLOT	0.0
12	B											
	43	1.00	SPH	3.4	6	28	8	HI	15	HEX	NSLOT	14.5
	44	1.00	SPH	3.4	6	28	8	HI	15	HEX	NSLOT	0.0
13	B											
	45	1.00	SPH	3.4	6	28	5	HI	25	HEX	NSLOT	0.0
	46	1.00	SPH	3.4	6	28	5	HI	25	HEX	NSLOT	14.5
14	B											
	47	1.00	SPH	3.4	6	28	5	HI	35	CON	NSLOT	0.0
	48	1.00	SPH	3.4	6	28	5	HI	35	CON	NSLOT	14.5
15	C											
	59	1.00	SPH	3.4	6	32	8	LOW	15	CON	NSLOT	12.0
	60	1.00	SPH	3.4	6	32	8	LOW	15	CON	NSLOT	3.0
	61	1.00	SPH	3.4	6	32	8	LOW	15	CON	NSLOT	9.0
	62	1.00	SPH	3.4	6	32	8	LOW	15	CON	NSLOT	6.0
16	A											
	63	1.00	SPH	3.4	6	32	8	LOW	35	HEX	SLOT	9.0
	64	1.00	SPH	3.4	6	32	8	LOW	35	HEX	SLOT	9.0
17	C											
	65	1.00	SPH	3.4	6	29	8	LOW	35	CON	NSLOT	6.0
	66	1.00	SPH	3.4	6	29	8	LOW	35	CON	NSLOT	9.0
	68	1.00	SPH	3.4	6	29	8	LOW	35	CON	NSLOT	3.0
18	C											
	69	0.75	SPH	3.4	6	30	8	LOW	35	CON	NSLOT	14.5
	70	0.75	SPH	3.4	6	30	8	LOW	35	CON	NSLOT	0.0
	201	0.75	SPH	3.4	5	30	8	LOW	35	CON	NSLOT	0.0
	202	0.75	SPH	3.4	5	30	8	LOW	35	CON	NSLOT	1.0
	203	0.75	SPH	3.4	5	30	8	LOW	35	CON	NSLOT	2.0
	204	0.75	SPH	3.4	5	30	8	LOW	35	CON	NSLOT	3.0
	205	0.75	SPH	3.4	5	30	8	LOW	35	CON	NSLOT	4.0
	206	0.75	SPH	3.4	5	30	8	LOW	35	CON	NSLOT	5.0
	207	0.75	SPH	3.4	5	30	8	LOW	35	CON	NSLOT	6.0
	208	0.75	SPH	3.4	5	30	8	LOW	35	CON	NSLOT	7.0
	210	0.75	SPH	3.4	5	30	8	LOW	35	CON	NSLOT	9.0
	211	0.75	SPH	3.4	5	30	8	LOW	35	CON	NSLOT	10.0
	212	0.75	SPH	3.4	5	30	8	LOW	35	CON	NSLOT	11.0
	213	0.75	SPH	3.4	5	30	8	LOW	35	CON	NSLOT	12.0
19	A											
	72	0.75	SPH	3.4	6	30	8	LOW	25	HEX	NSLOT	0.0

TABLE 1 (Cont'd.)

	98	0.75	SPH	3.4	6	30	5	HI	45	HEX	NSLOT	14.5
	99	0.75	SPH	3.4	6	30	5	HI	45	HEX	NSLOT	0.0
34	C											
	102	0.75	SPH	3.4	5	30	8	LOW	45	CON	NSLOT	0.0
	103	0.75	SPH	3.4	5	30	8	LOW	45	CON	NSLOT	1.0
	104	0.75	SPH	3.4	5	30	8	LOW	45	CON	NSLOT	2.0
	105	0.75	SPH	3.4	5	30	8	LOW	45	CON	NSLOT	3.0
	107	0.75	SPH	3.4	5	30	8	LOW	45	CON	NSLOT	14.5
	108	0.75	SPH	3.4	5	30	8	LOW	45	CON	NSLOT	14.0
	109	0.75	SPH	3.4	5	30	8	LOW	45	CON	NSLOT	13.0
	110	0.75	SPH	3.4	5	30	8	LOW	45	CON	NSLOT	12.0
	112	0.75	SPH	3.4	5	30	8	LOW	45	CON	NSLOT	5.0
	113	0.75	SPH	3.4	5	30	8	LOW	45	CON	NSLOT	6.0
	114	0.75	SPH	3.4	5	30	8	LOW	45	CON	NSLOT	7.0
35	C											
	300	1.00	SPH	3.0	2	30	8	LOW	35	CON	NSLOT	14.5
	301	1.00	SPH	3.0	2	30	8	LOW	35	CON	NSLOT	12.0
	303	1.00	SPH	3.0	2	30	8	LOW	35	CON	NSLOT	9.0
	304	1.00	SPH	3.0	2	30	8	LOW	35	CON	NSLOT	0.0
	305	1.00	SPH	3.0	2	30	8	LOW	35	CON	NSLOT	3.0
36	C											
	306	1.00	SPH	3.0	8	24	8	LOW	35	CON	NSLOT	0.0
	307	1.00	SPH	3.0	8	24	8	LOW	35	CON	NSLOT	3.0
	308	1.00	SPH	3.0	8	24	8	LOW	35	CON	NSLOT	6.0
	309	1.00	SPH	3.0	8	24	8	LOW	35	CON	NSLOT	9.0
	310	1.00	SPH	3.0	8	24	8	LOW	35	CON	NSLOT	12.0
37	C											
	312	1.00	SPH	3.4	8	24	8	LOW	35	CON	NSLOT	14.5
	313	1.00	SPH	3.4	8	24	8	LOW	35	CON	NSLOT	12.0
	314	1.00	SPH	3.4	8	24	8	LOW	35	CON	NSLOT	9.0
	315	1.00	SPH	3.4	8	24	8	LOW	35	CON	NSLOT	6.0
	316	1.00	SPH	3.4	8	24	8	LOW	35	CON	NSLOT	3.0
38	C											
	317	1.00	ASPH	3.4	8	24	8	LOW	35	CON	NSLOT	14.5
	320	1.00	ASPH	3.4	8	24	8	LOW	35	CON	NSLOT	9.0
	321	1.00	ASPH	3.4	8	24	8	LOW	35	CON	NSLOT	0.0
	322	1.00	ASPH	3.4	8	24	8	LOW	35	CON	NSLOT	3.0
39	C											
	323	1.00	ASPH	3.4	2	30	8	LOW	35	CON	NSLOT	3.0
	325	1.00	ASPH	3.4	2	30	8	LOW	35	CON	NSLOT	6.0
	326	1.00	ASPH	3.4	2	30	8	LOW	35	CON	NSLOT	9.0
	327	1.00	ASPH	3.4	2	30	8	LOW	35	CON	NSLOT	12.0
	328	1.00	ASPH	3.4	2	30	8	LOW	35	CON	NSLOT	14.5
40	C											
	329	1.00	ASPH	3.0	8	24	8	LOW	35	CON	NSLOT	14.5
	330	1.00	ASPH	3.0	8	24	8	LOW	35	CON	NSLOT	12.0
	331	1.00	ASPH	3.0	8	24	8	LOW	35	CON	NSLOT	9.0
	332	1.00	ASPH	3.0	8	24	8	LOW	35	CON	NSLOT	6.0
	333	1.00	ASPH	3.0	8	24	8	LOW	35	CON	NSLOT	0.0
	343	1.00	ASPH	3.0	8	24	8	LOW	35	CON	NSLOT	0.0
	344	1.00	ASPH	3.0	8	24	8	LOW	35	CON	NSLOT	3.0

TABLE 1 (Cont'd.)

41	C	334	1.00	ASPH	3.0	2	30	8	LOW	35	CON	NSLOT	0.0
		336	1.00	ASPH	3.0	2	30	8	LOW	35	CON	NSLOT	3.0
		337	1.00	ASPH	3.0	2	30	8	LOW	35	CON	NSLOT	14.5
		338	1.00	ASPH	3.0	2	30	8	LOW	35	CON	NSLOT	9.0
		339	1.00	ASPH	3.0	2	30	8	LOW	35	CON	NSLOT	12.0
		340	1.00	ASPH	3.0	2	30	8	LOW	35	CON	NSLOT	6.0
		341	1.00	ASPH	3.0	2	30	8	LOW	35	CON	NSLOT	3.0
		342	1.00	ASPH	3.0	2	30	8	LOW	35	CON	NSLOT	0.0
42	C	346	0.75	ASPH	3.0	8	24	8	LOW	35	CON	NSLOT	12.0
		348	0.75	ASPH	3.0	8	24	8	LOW	35	CON	NSLOT	14.5
		349	0.75	ASPH	3.0	8	24	8	LOW	35	CON	NSLOT	12.0
		350	0.75	ASPH	3.0	8	24	8	LOW	35	CON	NSLOT	0.0
		351	0.75	ASPH	3.0	8	24	8	LOW	35	CON	NSLOT	3.0
		352	0.75	ASPH	3.0	8	24	8	LOW	35	CON	NSLOT	6.0
		353	0.75	ASPH	3.0	8	24	8	LOW	35	CON	NSLOT	9.0
43	C	354	0.75	ASPH	3.0	2	30	8	LOW	35	CON	NSLOT	9.0
		355	0.75	ASPH	3.0	2	30	8	LOW	35	CON	NSLOT	6.0
		356	0.75	ASPH	3.0	2	30	8	LOW	35	CON	NSLOT	3.0
		357	0.75	ASPH	3.0	2	30	8	LOW	35	CON	NSLOT	0.0
		358	0.75	ASPH	3.0	2	30	8	LOW	35	CON	NSLOT	14.5
		359	0.75	ASPH	3.0	2	30	8	LOW	35	CON	NSLOT	12.0
44	C	360	0.75	SPH	3.4	8	24	8	LOW	35	CON	NSLOT	12.0
		361	0.75	SPH	3.4	8	24	8	LOW	35	CON	NSLOT	14.5
		362	0.75	SPH	3.4	8	24	8	LOW	35	CON	NSLOT	9.0
		363	0.75	SPH	3.4	8	24	8	LOW	35	CON	NSLOT	6.0
		364	0.75	SPH	3.4	8	24	8	LOW	35	CON	NSLOT	3.0
		365	0.75	SPH	3.4	8	24	8	LOW	35	CON	NSLOT	0.0

SPH = SPHERICAL
 ASPH = ASPHERICAL
 HI = HIGH
 CON = CONICAL
 HEX = HEXAGONAL
 SLOT = SLOTTED
 NSLOT = UNSLOTTED
 EXTR = EXTRACTOR
 NO. = NUMBER
 IN. = INCHES
 DIAM = DIAMETER
 DEG = DEGREES
 POS = POSITION

TABLE 2
TRIAL ATTRIBUTES

TRIAL NO.	PEBBLE DIAM (IN.)	PEBBLE SHAPE	PEBBLE BED HEIGHT (IN.)				EXTR DIAM (IN.)	BASE ANGLE (DEG)	BASE SHAPE	BASE SURFACE	PEBBLE SEEDING RADIUS (IN.)	SOURCE STRENGTH (MCI)	SEEDING INV (PEB)	RECIRC RATE (PEB PER MIN)	EXIT INV (PEB)	BED INV (PEB)
			PEBBLE SPECIFIC GRAVITY	PEBBLE DROP HEIGHT (IN.)	PEBBLE	EXTR										
10	1.00	SPH	3.4	6	28	8	LOW	35	CON	NSLOT	0.0	540	41237	430	60380	28800
11	1.00	SPH	3.4	6	28	8	LOW	35	CON	NSLOT	14.5	19	60516	435	90820	28800
12	1.00	SPH	3.4	6	28	8	LOW	35	CON	NSLOT	13.5	19	90932	440	117260	28800
13	1.00	SPH	3.4	6	28	8	LOW	25	CON	NSLOT	0.0	540	0	445	16160	28300
14	1.00	SPH	3.4	6	28	8	LOW	25	CON	NSLOT	13.5	19	48544	465	82730	28300
15	1.00	SPH	3.4	6	28	8	LOW	25	CON	NSLOT	14.5	19	82799	465	117950	28300
16	1.00	SPH	3.4	6	28	8	LOW	15	CON	NSLOT	0.0	540	10601	442	20750	27500
17	1.00	SPH	3.4	6	28	8	LOW	15	CON	NSLOT	13.5	19	20806	430	131200	27500
18	1.00	SPH	3.4	6	28	8	LOW	15	CON	NSLOT	13.5	19	0	430	30700	27500
19	1.00	SPH	3.4	6	28	8	LOW	15	CON	NSLOT	14.5	19	40884	478	269877	27500
20	1.00	SPH	3.4	6	28	8	LOW	25	HEX	NSLOT	0.0	540	0	430	18430	28300
21	1.00	SPH	3.4	6	28	8	LOW	25	HEX	NSLOT	13.5	19	18866	430	58048	28300
22	1.00	SPH	3.4	6	28	8	LOW	25	HEX	NSLOT	14.5	19	58145	430	104860	28300
23	1.00	SPH	3.4	6	28	8	LOW	35	HEX	NSLOT	14.5	19	51790	410	80650	28800
24	1.00	SPH	3.4	6	28	8	LOW	35	HEX	NSLOT	13.5	19	80656	400	114600	28800
25	1.00	SPH	3.4	6	28	8	LOW	35	HEX	NSLOT	0.0	540	114729	413	136340	28800
26	1.00	SPH	3.4	6	28	8	LOW	45	HEX	NSLOT	0.0	540	0	426	24852	29900
27	1.00	SPH	3.4	6	28	8	LOW	45	HEX	NSLOT	14.5	19	24899	424	57672	29900
28	1.00	SPH	3.4	6	28	8	LOW	45	HEX	NSLOT	13.5	19	57772	424	92608	29900
29	1.00	SPH	3.4	6	28	5	LOW	25	CON	NSLOT	0.0	540	56	367	17610	28300
30	1.00	SPH	3.4	6	28	5	LOW	25	CON	NSLOT	14.5	19	17701	354	69921	28300
31	1.00	SPH	3.4	6	28	5	LOW	35	HEX	NSLOT	0.0	540	385	356	23585	28800
32	1.00	SPH	3.4	6	28	5	LOW	35	HEX	NSLOT	14.5	19	23770	345	56138	28800
33	1.00	SPH	3.4	6	28	5	LOW	45	CON	NSLOT	0.0	540	0	352	23720	29900
34	1.00	SPH	3.4	6	28	5	LOW	45	CON	NSLOT	14.5	19	23861	346	56209	29900
35	1.00	SPH	3.4	6	28	5	LOW	15	HEX	NSLOT	0.0	540	0	348	12752	27500
36	1.00	SPH	3.4	6	28	5	LOW	15	HEX	NSLOT	14.5	19	0	365	77215	27500
37	1.00	SPH	3.4	6	28	8	HI	45	CON	NSLOT	0.0	540	0	395	25518	29900
38	1.00	SPH	3.4	6	28	8	HI	45	CON	NSLOT	14.5	19	25557	405	56673	29900
39	1.00	SPH	3.4	6	28	8	HI	25	CON	NSLOT	14.5	19	0	403	33218	28300
40	1.00	SPH	3.4	6	28	8	HI	25	CON	NSLOT	0.0	540	33252	395	51850	28300

TABLE 2 (Cont'd.)

41	1.00	SPH	3.4	6	28	8	HI	35	HEX	NSLOT	14.5	19	0	395	32212	28800
42	1.00	SPH	3.4	6	28	8	HI	35	HEX	NSLOT	0.0	540	32269	394	52524	28800
43	1.00	SPH	3.4	6	28	8	HI	15	HEX	NSLOT	14.5	19	0	399	103356	27500
44	1.00	SPH	3.4	6	28	8	HI	15	HEX	NSLOT	0.0	540	11068	400	22828	27500
45	1.00	SPH	3.4	6	28	5	HI	25	HEX	NSLOT	0.0	540	0	340	16370	28300
46	1.00	SPH	3.4	6	28	5	HI	25	HEX	NSLOT	14.5	19	16435	354	54252	28300
47	1.00	SPH	3.4	6	28	5	HI	35	CON	NSLOT	0.0	540	0	355	22232	28800
48	1.00	SPH	3.4	6	28	5	HI	35	CON	NSLOT	14.5	19	22257	335	53239	28800
49	1.00	SPH	3.4	6	28	5	HI	45	HEX	NSLOT	0.0	540	0	344	24319	29900
50	1.00	SPH	3.4	6	28	5	HI	45	HEX	NSLOT	14.5	19	24325	319	54318	29900
51	1.00	SPH	3.4	6	28	5	HI	15	CON	NSLOT	0.0	540	0	365	11113	27500
52	1.00	SPH	3.4	6	28	5	HI	15	CON	NSLOT	14.5	19	11213	376	77060	27500
53	1.00	SPH	3.4	6	28	5	HI	25	CON	NSLOT	14.5	19	0	228	44997	28300
54	1.00	SPH	3.4	6	28	5	HI	25	CON	NSLOT	14.5	19	44997	308	108010	28300
55	1.00	SPH	3.4	6	28	5	HI	25	CON	NSLOT	14.5	19	0	464	59477	28300
56	1.00	SPH	3.4	6	28	5	HI	25	CON	NSLOT	14.5	19	59477	370	105956	28300
57	1.00	SPH	3.4	6	28	5	HI	25	CON	NSLOT	14.5	19	0	381	49154	28300
58	1.00	SPH	3.4	6	28	5	HI	25	CON	NSLOT	14.5	19	49155	368	124042	28300
59	1.00	SPH	3.4	6	32	8	LOW	15	CON	NSLOT	12.0	19	0	403	27155	27500
60	1.00	SPH	3.4	6	32	8	LOW	15	CON	NSLOT	3.0	540	27750	400	37750	27500
61	1.00	SPH	3.4	6	32	8	LOW	15	CON	NSLOT	9.0	160	38008	411	53355	27500
62	1.00	SPH	3.4	6	32	8	LOW	15	CON	NSLOT	6.0	160	53522	402	65747	27500
63	1.00	SPH	3.4	6	32	8	LOW	35	HEX	SLOT	9.0	160	0	390	22860	32100
64	1.00	SPH	3.4	6	32	8	LOW	35	HEX	SLOT	9.0	160	22895	390	46752	32100
65	1.00	SPH	3.4	6	29	8	LOW	35	CON	NSLOT	6.0	160	0	385	23015	29600
66	1.00	SPH	3.4	6	29	8	LOW	35	CON	NSLOT	9.0	160	23168	385	47716	29600
67	1.00	SPH	3.4	6	29	8	LOW	35	CON	NSLOT	12.0	19	47787	385	77115	29600
68	1.00	SPH	3.4	6	29	8	LOW	35	CON	NSLOT	3.0	540	77136	385	96749	29600
69	0.75	SPH	3.4	6	30	8	LOW	35	CON	NSLOT	14.5	18	110897	408	201930	70000
70	0.75	SPH	3.4	6	30	8	LOW	35	CON	NSLOT	0.0	500	201981	400	251437	70000
71	0.75	SPH	3.4	6	30	8	LOW	25	HEX	NSLOT	14.5	18	0	406	132480	67700
72	0.75	SPH	3.4	6	30	8	LOW	25	HEX	NSLOT	0.0	500	132513	400	167615	67700
73	0.75	SPH	3.4	6	26	8	LOW	45	HEX	NSLOT	0.0	500	0	408	56206	63100
74	0.75	SPH	3.4	6	27	8	LOW	45	HEX	NSLOT	14.5	18	56208	405	129740	65100
75	0.75	SPH	3.4	6	30	8	LOW	15	CON	NSLOT	0.0	500	0	406	27115	66000
76	0.75	SPH	3.4	6	30	8	LOW	15	CON	NSLOT	14.5	18	27132	410	338378	66000
77	0.75	SPH	3.4	4	30	8	HI	35	HEX	NSLOT	14.5	18	0	400	82750	70000
78	0.75	SPH	3.4	4	30	8	HI	35	HEX	NSLOT	0.0	500	82770	407	132860	70000
79	0.75	SPH	3.4	6	30	8	HI	25	CON	NSLOT	14.5	18	0	405	79870	67700
80	0.75	SPH	3.4	6	30	8	HI	25	CON	NSLOT	0.0	500	79881	400	119360	67700
81	0.75	SPH	3.4	6	30	8	HI	45	CON	NSLOT	0.0	500	0	400	56482	71000
82	0.75	SPH	3.4	6	30	8	HI	45	CON	NSLOT	14.5	17	63769	400	134990	71000
83	0.75	SPH	3.4	6	30	8	HI	15	HEX	NSLOT	14.5	17	0	400	102940	66000
84	0.75	SPH	3.4	6	30	8	HI	15	HEX	NSLOT	0.0	500	102950	400	128348	66000
85	0.75	SPH	3.4	6	30	5	LOW	35	HEX	NSLOT	0.0	500	0	400	41235	70000
86	0.75	SPH	3.4	4	30	5	LOW	35	HEX	NSLOT	14.5	17	41242	400	152510	70000
87	0.75	SPH	3.4	6	30	5	LOW	25	CON	NSLOT	0.0	500	0	400	25340	67700
88	0.75	SPH	3.4	6	30	5	LOW	25	CON	NSLOT	14.5	17	25432	400	150760	67700
89	0.75	SPH	3.4	8	28	5	LOW	45	CON	NSLOT	0.0	500	0	400	53427	67000
90	0.75	SPH	3.4	8	29	5	LOW	45	CON	NSLOT	14.5	18	53443	400	139060	69000
91	0.75	SPH	3.4	0	30	5	LOW	15	HEX	NSLOT	0.0	500	0	405	20310	66000
92	0.75	SPH	3.4	0	30	5	LOW	15	HEX	NSLOT	14.5	17	20323	403	109657	66000
93	0.75	SPH	3.4	0	30	5	HI	35	CON	NSLOT	0.0	500	0	380	36367	70000
94	0.75	SPH	3.4	0	30	5	HI	35	CON	NSLOT	14.5	17	36381	300	172660	70000
95	0.75	SPH	3.4	6	30	5	HI	35	CON	NSLOT	14.5	17	0	400	76730	70000
96	0.75	SPH	3.4	5	30	5	HI	25	HEX	NSLOT	14.5	17	0	400	213461	67700
97	0.75	SPH	3.4	5	30	5	HI	25	HEX	NSLOT	0.0	500	213477	400	241575	67700
98	0.75	SPH	3.4	5	30	5	HI	45	HEX	NSLOT	14.5	18	0	400	87610	71000

TABLE 2 (Cont'd.)

99	0.75	SPH	3.4	6	30	5	HI	45	HEX	NSLOT	0.0	500	87624	402	140285	71000	
100	0.75	SPH	3.4	4	30	5	HI	15	CON	NSLOT	14.5	18		0	400	741085	66000
101	0.75	SPH	3.4	4	30	5	HI	15	CON	NSLOT	0.0	500	741108	424	760295	66000	
102	0.75	SPH	3.4	5	30	8	LOW	45	CON	NSLOT	0.0	500		0	340	49886	71000
103	0.75	SPH	3.4	5	30	8	LOW	45	CON	NSLOT	1.0	500	53467	340	104980	71000	
104	0.75	SPH	3.4	5	30	8	LOW	45	CON	NSLOT	2.0	500	105012	340	158282	71000	
105	0.75	SPH	3.4	5	30	8	LOW	45	CON	NSLOT	3.0	500	158311	340	211370	71000	
106	0.75	SPH	3.4	5	30	8	LOW	45	CON	NSLOT	4.0	500	211377	340	265960	71000	
107	0.75	SPH	3.4	5	30	8	LOW	45	CON	NSLOT	14.5	18	265964	406	344290	71000	
108	0.75	SPH	3.4	5	30	8	LOW	45	CON	NSLOT	14.0	18	344320	406	419870	71000	
109	0.75	SPH	3.4	5	30	8	LOW	45	CON	NSLOT	13.0	18	419900	400	489401	71000	
110	0.75	SPH	3.4	5	30	8	LOW	45	CON	NSLOT	12.0	19	489440	400	557140	71000	
111	0.75	SPH	3.4	5	30	8	LOW	45	CON	NSLOT	11.0	19	557167	400	621440	71000	
112	0.75	SPH	3.4	5	30	8	LOW	45	CON	NSLOT	5.0	150	621474	400	677307	71000	
113	0.75	SPH	3.4	5	30	8	LOW	45	CON	NSLOT	6.0	150	677337	380	734600	71000	
114	0.75	SPH	3.4	5	30	8	LOW	45	CON	NSLOT	7.0	150	734619	400	792480	71000	
115	0.75	SPH	3.4	5	30	8	LOW	45	CON	NSLOT	8.0	150	792514	400	852160	71000	
120	0.75	SPH	3.4	5	30	8	LOW	15	CON	NSLOT	14.5	18		0	350	150100	66000
121	0.75	SPH	3.4	5	30	8	LOW	15	CON	NSLOT	14.0	18		0	350	107010	66000
122	0.75	SPH	3.4	5	30	8	LOW	15	CON	NSLOT	13.0	18		0	350	73330	66000
123	0.75	SPH	3.4	5	30	8	LOW	15	CON	NSLOT	12.0	18		0	350	68595	66000
124	0.75	SPH	3.4	5	30	8	LOW	15	CON	NSLOT	11.0	18		0	350	36970	66000
125	0.75	SPH	3.4	5	30	8	LOW	15	CON	NSLOT	10.0	150		0	350	36760	66000
126	0.75	SPH	3.4	5	30	8	LOW	15	CON	NSLOT	9.0	150		0	350	28630	66000
127	0.75	SPH	3.4	5	30	8	LOW	15	CON	NSLOT	8.0	150		0	350	25400	66000
128	0.75	SPH	3.4	5	30	8	LOW	15	CON	NSLOT	7.0	150		0	350	24550	66000
129	0.75	SPH	3.4	5	30	8	LOW	15	CON	NSLOT	6.0	150		0	350	22400	66000
130	0.75	SPH	3.4	5	30	8	LOW	15	CON	NSLOT	5.0	150		0	350	21230	66000
131	0.75	SPH	3.4	5	30	8	LOW	15	CON	NSLOT	4.0	150		0	350	21200	66000
132	0.75	SPH	3.4	5	30	8	LOW	15	CON	NSLOT	3.0	540		0	350	21000	66000
133	0.75	SPH	3.4	5	30	8	LOW	15	CON	NSLOT	2.0	540		0	350	20850	66000
134	0.75	SPH	3.4	5	30	8	LOW	15	CON	NSLOT	1.0	540		0	350	20140	66000
135	0.75	SPH	3.4	5	30	8	LOW	15	CON	NSLOT	0.0	540		0	350	19890	66000
136	0.75	SPH	3.4	6	29	8	LOW	25	CON	NSLOT	14.5	18		0	350	248385	65700
137	0.75	SPH	3.4	6	30	8	LOW	25	CON	NSLOT	14.0	18		0	350	146400	67700
138	0.75	SPH	3.4	6	30	8	LOW	25	CON	NSLOT	13.0	18		0	350	126000	67700
201	0.75	SPH	3.4	5	30	8	LOW	35	CON	NSLOT	0.0	500		0	400	46650	70000
202	0.75	SPH	3.4	5	30	8	LOW	35	CON	NSLOT	1.0	500	46696	400	95300	70000	
203	0.75	SPH	3.4	5	30	8	LOW	35	CON	NSLOT	2.0	500	95300	400	146250	70000	
204	0.75	SPH	3.4	5	30	8	LOW	35	CON	NSLOT	3.0	500	146264	400	198720	70000	
205	0.75	SPH	3.4	5	30	8	LOW	35	CON	NSLOT	4.0	150	198757	400	250360	70000	
206	0.75	SPH	3.4	5	30	8	LOW	35	CON	NSLOT	5.0	150		0	400	51230	70000
207	0.75	SPH	3.4	5	30	8	LOW	35	CON	NSLOT	6.0	150	51243	400	106680	70000	
208	0.75	SPH	3.4	5	30	8	LOW	35	CON	NSLOT	7.0	15	106695	400	163800	70000	
209	0.75	SPH	3.4	5	30	8	LOW	35	CON	NSLOT	8.0	150	163830	400	221670	70000	
210	0.75	SPH	3.4	5	30	8	LOW	35	CON	NSLOT	9.0	150	221680	400	279520	70000	
211	0.75	SPH	3.4	5	30	8	LOW	35	CON	NSLOT	10.0	150	279533	400	342550	70000	
212	0.75	SPH	3.4	5	30	8	LOW	35	CON	NSLOT	11.0	18	342563	400	407220	70000	
213	0.75	SPH	3.4	5	30	8	LOW	35	CON	NSLOT	12.0	18	407235	400	475070	70000	
214	0.75	SPH	3.4	5	30	8	LOW	35	CON	NSLOT	13.0	18	475085	400	552870	70000	
215	0.75	SPH	3.4	5	30	8	LOW	35	CON	NSLOT	14.0	18	552880	400	627930	70000	
300	1.00	SPH	3.0	2	30	8	LOW	35	CON	NSLOT	14.5	17		0	300	35250	30500
301	1.00	SPH	3.0	2	30	8	LOW	35	CON	NSLOT	12.0	150	35250	300	63095	30500	
302	1.00	SPH	3.0	2	30	8	LOW	35	CON	NSLOT	6.0	150	63095	300	86514	30500	
303	1.00	SPH	3.0	2	30	8	LOW	35	CON	NSLOT	9.0	150	86515	300	111843	30500	
304	1.00	SPH	3.0	2	30	8	LOW	35	CON	NSLOT	0.0	500	111845	300	134231	30500	
305	1.00	SPH	3.0	2	30	8	LOW	35	CON	NSLOT	3.0	500	134231	300	156775	30500	
306	1.00	SPH	3.0	8	24	8	LOW	35	CON	NSLOT	0.0	500		0	300	14829	26600

TABLE 2 (Cont'd.)

307	1.00	SPH	3.0	8	24	8	LOW	35	CON	NSLOT	3.0	500	14831	300	27463	26600
308	1.00	SPH	3.0	8	24	8	LOW	35	CON	NSLOT	6.0	150	27499	300	44113	26600
309	1.00	SPH	3.0	8	24	8	LOW	35	CON	NSLOT	9.0	150	44113	300	62107	26600
310	1.00	SPH	3.0	8	24	8	LOW	35	CON	NSLOT	12.0	150	134900	300	160943	26600
311	1.00	SPH	3.0	8	24	8	LOW	35	CON	NSLOT	14.5	150	160946	300	197583	26600
312	1.00	SPH	3.4	8	24	8	LOW	35	CON	NSLOT	14.5	150	0	300	37910	26600
313	1.00	SPH	3.4	8	24	8	LOW	35	CON	NSLOT	12.0	17	37910	320	64403	26600
314	1.00	SPH	3.4	8	24	8	LOW	35	CON	NSLOT	9.0	150	64700	300	84000	26600
315	1.00	SPH	3.4	8	24	8	LOW	35	CON	NSLOT	6.0	500	84000	300	98700	26600
316	1.00	SPH	3.4	8	24	8	LOW	35	CON	NSLOT	3.0	500	98700	300	114600	26600
317	1.00	ASPH	3.4	8	24	8	LOW	35	CON	NSLOT	14.5	22	0	350	41050	29500
318	1.00	ASPH	3.4	8	24	8	LOW	35	CON	NSLOT	12.0	22	0	350	34556	29500
320	1.00	ASPH	3.4	8	24	8	LOW	35	CON	NSLOT	9.0	22	75571	350	98186	29500
321	1.00	ASPH	3.4	8	24	8	LOW	35	CON	NSLOT	0.0	500	98186	350	115830	29500
322	1.00	ASPH	3.4	8	24	8	LOW	35	CON	NSLOT	3.0	500	115830	350	133849	29500
323	1.00	ASPH	3.4	2	30	8	LOW	35	CON	NSLOT	3.0	500	133850	350	158525	35000
324	1.00	ASPH	3.4	2	30	8	LOW	35	CON	NSLOT	0.0	500	158525	350	184396	35000
325	1.00	ASPH	3.4	2	30	8	LOW	35	CON	NSLOT	6.0	135	184398	350	211351	35000
326	1.00	ASPH	3.4	2	30	8	LOW	35	CON	NSLOT	9.0	22	211351	350	239523	35000
327	1.00	ASPH	3.4	2	30	8	LOW	35	CON	NSLOT	12.0	22	239523	350	274000	35000
328	1.00	ASPH	3.4	2	30	8	LOW	35	CON	NSLOT	14.5	22	274000	350	313880	35000
329	1.00	ASPH	3.0	8	24	8	LOW	35	CON	NSLOT	14.5	22	0	300	38518	29500
330	1.00	ASPH	3.0	8	24	8	LOW	35	CON	NSLOT	12.0	22	38519	300	73000	29500
331	1.00	ASPH	3.0	8	24	8	LOW	35	CON	NSLOT	9.0	22	73000	330	93360	29500
332	1.00	ASPH	3.0	8	24	8	LOW	35	CON	NSLOT	6.0	135	93360	330	111750	29500
333	1.00	ASPH	3.0	8	24	8	LOW	35	CON	NSLOT	0.0	560	126590	330	142850	29500
334	1.00	ASPH	3.0	2	30	8	LOW	35	CON	NSLOT	0.0	560	142850	330	166690	35000
335	1.00	ASPH	3.0	2	30	8	LOW	35	CON	NSLOT	6.0	135	166690	330	193000	35000
336	1.00	ASPH	3.0	2	30	8	LOW	35	CON	NSLOT	3.0	135	193000	330	217300	35000
337	1.00	ASPH	3.0	2	30	8	LOW	35	CON	NSLOT	14.5	22	217300	340	263950	35000
338	1.00	ASPH	3.0	2	30	8	LOW	35	CON	NSLOT	9.0	22	263950	340	292000	35000
339	1.00	ASPH	3.0	2	30	8	LOW	35	CON	NSLOT	12.0	22	292000	340	324400	35000
340	1.00	ASPH	3.0	2	30	8	LOW	35	CON	NSLOT	6.0	135	0	340	25061	35000
341	1.00	ASPH	3.0	2	30	8	LOW	35	CON	NSLOT	3.0	135	25061	340	48109	35000
342	1.00	ASPH	3.0	2	30	8	LOW	35	CON	NSLOT	0.0	135	48109	340	71733	35000
343	1.00	ASPH	3.0	8	24	8	LOW	35	CON	NSLOT	0.0	135	77253	340	92172	29500
344	1.00	ASPH	3.0	8	24	8	LOW	35	CON	NSLOT	3.0	135	92172	340	107077	29500
346	0.75	ASPH	3.0	8	24	8	LOW	35	CON	NSLOT	12.0	18	112320	350	184320	68000
347	0.75	ASPH	3.0	8	24	8	LOW	35	CON	NSLOT	0.0	145	184320	350	221190	68000
348	0.75	ASPH	3.0	8	24	8	LOW	35	CON	NSLOT	14.5	19	221190	360	303787	68000
349	0.75	ASPH	3.0	8	24	8	LOW	35	CON	NSLOT	12.0	19	303787	360	368308	68000
350	0.75	ASPH	3.0	8	24	8	LOW	35	CON	NSLOT	0.0	160	368308	360	402640	68000
351	0.75	ASPH	3.0	8	24	8	LOW	35	CON	NSLOT	3.0	160	402643	390	438277	68000
352	0.75	ASPH	3.0	8	24	8	LOW	35	CON	NSLOT	6.0	160	438277	400	476815	68000
353	0.75	ASPH	3.0	8	24	8	LOW	35	CON	NSLOT	9.0	160	476816	380	523517	68000
354	0.75	ASPH	3.0	2	30	8	LOW	35	CON	NSLOT	9.0	160	523520	360	589600	80000
355	0.75	ASPH	3.0	2	30	8	LOW	35	CON	NSLOT	6.0	160	589600	360	649356	80000
356	0.75	ASPH	3.0	2	30	8	LOW	35	CON	NSLOT	3.0	160	649356	420	706478	80000
357	0.75	ASPH	3.0	2	30	8	LOW	35	CON	NSLOT	0.0	160	706478	440	763773	80000
358	0.75	ASPH	3.0	2	30	8	LOW	35	CON	NSLOT	14.5	19	763773	440	856666	80000
359	0.75	ASPH	3.0	2	30	8	LOW	35	CON	NSLOT	12.0	19	856666	430	937800	80000
360	0.75	SPH	3.4	8	24	8	LOW	35	CON	NSLOT	12.0	18	0	430	57736	58000
361	0.75	SPH	3.4	8	24	8	LOW	35	CON	NSLOT	14.5	18	57743	420	140253	58000
362	0.75	SPH	3.4	8	24	8	LOW	35	CON	NSLOT	9.0	145	140256	440	182173	58000
363	0.75	SPH	3.4	8	24	8	LOW	35	CON	NSLOT	6.0	145	182173	410	218920	58000
364	0.75	SPH	3.4	8	24	8	LOW	35	CON	NSLOT	3.0	145	218920	430	252180	58000
365	0.75	SPH	3.4	8	24	8	LOW	35	CON	NSLOT	0.0	145	252180	440	285820	58000

TABLE 2 (Cont'd.)

SPH = SPHERICAL
ASPH = ASPHERICAL
HI = HIGH
CON = CONICAL
HEX = HEXAGONAL
SLOT = SLOTTED
NSLOT = UNSLOTTED
EXTR = EXTRACTOR
INV = INVENTORY
NO. = NUMBER
IN. = INCHES
DIAM = DIAMETER
DEG = DEGREES
MCI = MILLICURIES
RECIRC = RECIRCULATION
MIN = MINUTE
PEB = PEBBLES
POS = POSITION

TABLE 3

GROUPS OF TRIALS WITH COMMON ATTRIBUTES

TRIAL NO.	PEBBLE DIAM (IN.)	PEBBLE SHAPE	PEBBLE BED HEIGHT (IN.)			EXTR DIAM (IN.)	EXTR POS	BASE ANGLE (DEG)	BASE SHAPE	BASE SURFACE	PEBBLE SEEDING RADIUS (IN.)
			PEBBLE SPECIFIC GRAVITY	PEBBLE DROP HEIGHT (IN.)	PEBBLE DIA						
10	1.00	SPH	3.4	6	28	8	LOW	35	CON	NSLOT	0.0
11	1.00	SPH	3.4	6	28	8	LOW	35	CON	NSLOT	14.5
12	1.00	SPH	3.4	6	28	8	LOW	35	CON	NSLOT	13.5
13	1.00	SPH	3.4	6	28	8	LOW	25	CON	NSLOT	0.0
14	1.00	SPH	3.4	6	28	8	LOW	25	CON	NSLOT	13.5
15	1.00	SPH	3.4	6	28	8	LOW	25	CON	NSLOT	14.5
16	1.00	SPH	3.4	6	28	8	LOW	15	CON	NSLOT	0.0
17	1.00	SPH	3.4	6	28	8	LOW	15	CON	NSLOT	13.5
18	1.00	SPH	3.4	6	28	8	LOW	15	CON	NSLOT	13.5
19	1.00	SPH	3.4	6	28	8	LOW	15	CON	NSLOT	14.5
20	1.00	SPH	3.4	6	28	8	LOW	25	HEX	NSLOT	0.0
21	1.00	SPH	3.4	6	28	8	LOW	25	HEX	NSLOT	13.5
22	1.00	SPH	3.4	6	28	8	LOW	25	HEX	NSLOT	14.5
23	1.00	SPH	3.4	6	28	8	LOW	35	HEX	NSLOT	14.5
24	1.00	SPH	3.4	6	28	8	LOW	35	HEX	NSLOT	13.5
25	1.00	SPH	3.4	6	28	8	LOW	35	HEX	NSLOT	0.0
26	1.00	SPH	3.4	6	28	8	LOW	45	HEX	NSLOT	0.0
27	1.00	SPH	3.4	6	28	8	LOW	45	HEX	NSLOT	14.5
28	1.00	SPH	3.4	6	28	8	LOW	45	HEX	NSLOT	13.5
29	1.00	SPH	3.4	6	28	5	LOW	25	CON	NSLOT	0.0
30	1.00	SPH	3.4	6	28	5	LOW	25	CON	NSLOT	14.5
31	1.00	SPH	3.4	6	28	5	LOW	35	HEX	NSLOT	0.0
32	1.00	SPH	3.4	6	28	5	LOW	35	HEX	NSLOT	14.5
33	1.00	SPH	3.4	6	28	5	LOW	45	CON	NSLOT	0.0
34	1.00	SPH	3.4	6	28	5	LOW	45	CON	NSLOT	14.5

TABLE 3 (Cont'd.)

35	1.00	SPH	3.4	6	28	5	LOW	15	HEX	NSLOT	0.0
36	1.00	SPH	3.4	6	28	5	LOW	15	HEX	NSLOT	14.5
37	1.00	SPH	3.4	6	28	8	HI	45	CON	NSLOT	0.0
38	1.00	SPH	3.4	6	28	8	HI	45	CON	NSLOT	14.5
39	1.00	SPH	3.4	6	28	8	HI	25	CON	NSLOT	14.5
40	1.00	SPH	3.4	6	28	8	HI	25	CON	NSLOT	0.0
41	1.00	SPH	3.4	6	28	8	HI	35	HEX	NSLOT	14.5
42	1.00	SPH	3.4	6	28	8	HI	35	HEX	NSLOT	0.0
43	1.00	SPH	3.4	6	28	8	HI	15	HEX	NSLOT	14.5
44	1.00	SPH	3.4	6	28	8	HI	15	HEX	NSLOT	0.0
45	1.00	SPH	3.4	6	28	5	HI	25	HEX	NSLOT	0.0
46	1.00	SPH	3.4	6	28	5	HI	25	HEX	NSLOT	14.5
47	1.00	SPH	3.4	6	28	5	HI	35	CON	NSLOT	0.0
48	1.00	SPH	3.4	6	28	5	HI	35	CON	NSLOT	14.5
49	1.00	SPH	3.4	6	28	5	HI	45	HEX	NSLOT	0.0
50	1.00	SPH	3.4	6	28	5	HI	45	HEX	NSLOT	14.5
51	1.00	SPH	3.4	6	28	5	HI	15	CON	NSLOT	0.0
52	1.00	SPH	3.4	6	28	5	HI	15	CON	NSLOT	14.5
53	1.00	SPH	3.4	6	28	5	HI	25	CON	NSLOT	14.5
54	1.00	SPH	3.4	6	28	5	HI	25	CON	NSLOT	14.5
55	1.00	SPH	3.4	6	28	5	HI	25	CON	NSLOT	14.5
56	1.00	SPH	3.4	6	28	5	HI	25	CON	NSLOT	14.5
57	1.00	SPH	3.4	6	28	5	HI	25	CON	NSLOT	14.5
58	1.00	SPH	3.4	6	28	5	HI	25	CON	NSLOT	14.5
59	1.00	SPH	3.4	6	32	8	LOW	15	CON	NSLOT	12.0
60	1.00	SPH	3.4	6	32	8	LOW	15	CON	NSLOT	3.0
61	1.00	SPH	3.4	6	32	8	LOW	15	CON	NSLOT	9.0
62	1.00	SPH	3.4	6	32	8	LOW	15	CON	NSLOT	6.0
63	1.00	SPH	3.4	6	32	8	LOW	35	HEX	SLOT	9.0
64	1.00	SPH	3.4	6	32	8	LOW	35	HEX	SLOT	9.0
65	1.00	SPH	3.4	6	29	8	LOW	35	CON	NSLOT	6.0
66	1.00	SPH	3.4	6	29	8	LOW	35	CON	NSLOT	9.0
67	1.00	SPH	3.4	6	29	8	LOW	35	CON	NSLOT	12.0
68	1.00	SPH	3.4	6	29	8	LOW	35	CON	NSLOT	3.0
69	0.75	SPH	3.4	6	30	8	LOW	35	CON	NSLOT	14.5
70	0.75	SPH	3.4	6	30	8	LOW	35	CON	NSLOT	0.0
201	0.75	SPH	3.4	5	30	8	LOW	35	CON	NSLOT	0.0
202	0.75	SPH	3.4	5	30	8	LOW	35	CON	NSLOT	1.0
203	0.75	SPH	3.4	5	30	8	LOW	35	CON	NSLOT	2.0
204	0.75	SPH	3.4	5	30	8	LOW	35	CON	NSLOT	3.0
205	0.75	SPH	3.4	5	30	8	LOW	35	CON	NSLOT	4.0
206	0.75	SPH	3.4	5	30	8	LOW	35	CON	NSLOT	5.0
207	0.75	SPH	3.4	5	30	8	LOW	35	CON	NSLOT	6.0
208	0.75	SPH	3.4	5	30	8	LOW	35	CON	NSLOT	7.0

TABLE 3 (Cont'd.)

209	0.75	SPH	3.4	5	30	8	LOW	35	CON	NSLOT	8.0
210	0.75	SPH	3.4	5	30	8	LOW	35	CON	NSLOT	9.0
211	0.75	SPH	3.4	5	30	8	LOW	35	CON	NSLOT	10.0
212	0.75	SPH	3.4	5	30	8	LOW	35	CON	NSLOT	11.0
213	0.75	SPH	3.4	5	30	8	LOW	35	CON	NSLOT	12.0
214	0.75	SPH	3.4	5	30	8	LOW	35	CON	NSLOT	13.0
215	0.75	SPH	3.4	5	30	8	LOW	35	CON	NSLOT	14.0
71	0.75	SPH	3.4	6	30	8	LOW	25	HEX	NSLOT	14.5
72	0.75	SPH	3.4	6	30	8	LOW	25	HEX	NSLOT	0.0
73	0.75	SPH	3.4	6	26	8	LOW	45	HEX	NSLOT	0.0
74	0.75	SPH	3.4	6	27	8	LOW	45	HEX	NSLOT	14.5
75	0.75	SPH	3.4	6	30	8	LOW	15	CON	NSLOT	0.0
76	0.75	SPH	3.4	6	30	8	LOW	15	CON	NSLOT	14.5
120	0.75	SPH	3.4	5	30	8	LOW	15	CON	NSLOT	14.5
121	0.75	SPH	3.4	5	30	8	LOW	15	CON	NSLOT	14.0
122	0.75	SPH	3.4	5	30	8	LOW	15	CON	NSLOT	13.0
123	0.75	SPH	3.4	5	30	8	LOW	15	CON	NSLOT	12.0
124	0.75	SPH	3.4	5	30	8	LOW	15	CON	NSLOT	11.0
125	0.75	SPH	3.4	5	30	8	LOW	15	CON	NSLOT	10.0
126	0.75	SPH	3.4	5	30	8	LOW	15	CON	NSLOT	9.0
127	0.75	SPH	3.4	5	30	8	LOW	15	CON	NSLOT	8.0
128	0.75	SPH	3.4	5	30	8	LOW	15	CON	NSLOT	7.0
129	0.75	SPH	3.4	5	30	8	LOW	15	CON	NSLOT	6.0
130	0.75	SPH	3.4	5	30	8	LOW	15	CON	NSLOT	5.0
131	0.75	SPH	3.4	5	30	8	LOW	15	CON	NSLOT	4.0
132	0.75	SPH	3.4	5	30	8	LOW	15	CON	NSLOT	3.0
133	0.75	SPH	3.4	5	30	8	LOW	15	CON	NSLOT	2.0
134	0.75	SPH	3.4	5	30	8	LOW	15	CON	NSLOT	1.0
135	0.75	SPH	3.4	5	30	8	LOW	15	CON	NSLOT	0.0
77	0.75	SPH	3.4	4	30	8	HI	35	HEX	NSLOT	14.5
78	0.75	SPH	3.4	4	30	8	HI	35	HEX	NSLOT	0.0
79	0.75	SPH	3.4	6	30	8	HI	25	CON	NSLOT	14.5
80	0.75	SPH	3.4	6	30	8	HI	25	CON	NSLOT	0.0
81	0.75	SPH	3.4	6	30	8	HI	45	CON	NSLOT	0.0
82	0.75	SPH	3.4	6	30	8	HI	45	CON	NSLOT	14.5
83	0.75	SPH	3.4	6	30	8	HI	15	HEX	NSLOT	14.5
84	0.75	SPH	3.4	6	30	8	HI	15	HEX	NSLOT	0.0
85	0.75	SPH	3.4	6	30	5	LOW	35	HEX	NSLOT	0.0
86	0.75	SPH	3.4	4	30	5	LOW	35	HEX	NSLOT	14.5
87	0.75	SPH	3.4	6	30	5	LOW	25	CON	NSLOT	0.0
88	0.75	SPH	3.4	6	30	5	LOW	25	CON	NSLOT	14.5
89	0.75	SPH	3.4	8	28	5	LOW	45	CON	NSLOT	0.0
90	0.75	SPH	3.4	8	29	5	LOW	45	CON	NSLOT	14.5
91	0.75	SPH	3.4	0	30	5	LOW	15	HEX	NSLOT	0.0
92	0.75	SPH	3.4	0	30	5	LOW	15	HEX	NSLOT	14.5

TABLE 3 (Cont'd.)

93	0.75	SPH	3.4	0	30	5	HI	35	CON	NSLOT	0.0
94	0.75	SPH	3.4	0	30	5	HI	35	CON	NSLOT	14.5
95	0.75	SPH	3.4	6	30	5	HI	35	CON	NSLOT	14.5
96	0.75	SPH	3.4	5	30	5	HI	25	HEX	NSLOT	14.5
97	0.75	SPH	3.4	5	30	5	HI	25	HEX	NSLOT	0.0
98	0.75	SPH	3.4	6	30	5	HI	45	HEX	NSLOT	14.5
99	0.75	SPH	3.4	6	30	5	HI	45	HEX	NSLOT	0.0
100	0.75	SPH	3.4	4	30	5	HI	15	CON	NSLOT	14.5
101	0.75	SPH	3.4	4	30	5	HI	15	CON	NSLOT	0.0
102	0.75	SPH	3.4	5	30	8	LOW	45	CON	NSLOT	0.0
103	0.75	SPH	3.4	5	30	8	LOW	45	CON	NSLOT	1.0
104	0.75	SPH	3.4	5	30	8	LOW	45	CON	NSLOT	2.0
105	0.75	SPH	3.4	5	30	8	LOW	45	CON	NSLOT	3.0
106	0.75	SPH	3.4	5	30	8	LOW	45	CON	NSLOT	4.0
107	0.75	SPH	3.4	5	30	8	LOW	45	CON	NSLOT	14.5
108	0.75	SPH	3.4	5	30	8	LOW	45	CON	NSLOT	14.0
109	0.75	SPH	3.4	5	30	8	LOW	45	CON	NSLOT	13.0
110	0.75	SPH	3.4	5	30	8	LOW	45	CON	NSLOT	12.0
111	0.75	SPH	3.4	5	30	8	LOW	45	CON	NSLOT	11.0
112	0.75	SPH	3.4	5	30	8	LOW	45	CON	NSLOT	5.0
113	0.75	SPH	3.4	5	30	8	LOW	45	CON	NSLOT	6.0
114	0.75	SPH	3.4	5	30	8	LOW	45	CON	NSLOT	7.0
115	0.75	SPH	3.4	5	30	8	LOW	45	CON	NSLOT	8.0
136	0.75	SPH	3.4	6	29	8	LOW	25	CON	NSLOT	14.5
137	0.75	SPH	3.4	6	30	8	LOW	25	CON	NSLOT	14.0
138	0.75	SPH	3.4	6	30	8	LOW	25	CON	NSLOT	13.0
300	1.00	SPH	3.0	2	30	8	LOW	35	CON	NSLOT	14.5
301	1.00	SPH	3.0	2	30	8	LOW	35	CON	NSLOT	12.0
302	1.00	SPH	3.0	2	30	8	LOW	35	CON	NSLOT	6.0
303	1.00	SPH	3.0	2	30	8	LOW	35	CON	NSLOT	9.0
304	1.00	SPH	3.0	2	30	8	LOW	35	CON	NSLOT	0.0
305	1.00	SPH	3.0	2	30	8	LOW	35	CON	NSLOT	3.0
306	1.00	SPH	3.0	8	24	8	LOW	35	CON	NSLOT	0.0
307	1.00	SPH	3.0	8	24	8	LOW	35	CON	NSLOT	3.0
308	1.00	SPH	3.0	8	24	8	LOW	35	CON	NSLOT	6.0
309	1.00	SPH	3.0	8	24	8	LOW	35	CON	NSLOT	9.0
310	1.00	SPH	3.0	8	24	8	LOW	35	CON	NSLOT	12.0
311	1.00	SPH	3.0	8	24	8	LOW	35	CON	NSLOT	14.5
312	1.00	SPH	3.4	8	24	8	LOW	35	CON	NSLOT	14.5
313	1.00	SPH	3.4	8	24	8	LOW	35	CON	NSLOT	12.0
314	1.00	SPH	3.4	8	24	8	LOW	35	CON	NSLOT	9.0
315	1.00	SPH	3.4	8	24	8	LOW	35	CON	NSLOT	6.0
316	1.00	SPH	3.4	8	24	8	LOW	35	CON	NSLOT	3.0
317	1.00	ASPH	3.4	8	24	8	LOW	35	CON	NSLOT	14.5
318	1.00	ASPH	3.4	8	24	8	LOW	35	CON	NSLOT	12.0
320	1.00	ASPH	3.4	8	24	8	LOW	35	CON	NSLOT	9.0
321	1.00	ASPH	3.4	8	24	8	LOW	35	CON	NSLOT	0.0

TABLE 3 (Cont'd.)

322	1.00	ASPH	3.4	8	24	8	LOW	35	CON	NSLOT	3.0
323	1.00	ASPH	3.4	2	30	8	LOW	35	CON	NSLOT	3.0
324	1.00	ASPH	3.4	2	30	8	LOW	35	CON	NSLOT	0.0
325	1.00	ASPH	3.4	2	30	8	LOW	35	CON	NSLOT	6.0
326	1.00	ASPH	3.4	2	30	8	LOW	35	CON	NSLOT	9.0
327	1.00	ASPH	3.4	2	30	8	LOW	35	CON	NSLOT	12.0
328	1.00	ASPH	3.4	2	30	8	LOW	35	CON	NSLOT	14.5
329	1.00	ASPH	3.0	8	24	8	LOW	35	CON	NSLOT	14.5
330	1.00	ASPH	3.0	8	24	8	LOW	35	CON	NSLOT	12.0
331	1.00	ASPH	3.0	8	24	8	LOW	35	CON	NSLOT	9.0
332	1.00	ASPH	3.0	8	24	8	LOW	35	CON	NSLOT	6.0
333	1.00	ASPH	3.0	8	24	8	LOW	35	CON	NSLOT	0.0
343	1.00	ASPH	3.0	8	24	8	LOW	35	CON	NSLOT	0.0
344	1.00	ASPH	3.0	8	24	8	LOW	35	CON	NSLOT	3.0
334	1.00	ASPH	3.0	2	30	8	LOW	35	CON	NSLOT	0.0
335	1.00	ASPH	3.0	2	30	8	LOW	35	CON	NSLOT	6.0
336	1.00	ASPH	3.0	2	30	8	LOW	35	CON	NSLOT	3.0
337	1.00	ASPH	3.0	2	30	8	LOW	35	CON	NSLOT	14.5
338	1.00	ASPH	3.0	2	30	8	LOW	35	CON	NSLOT	9.0
339	1.00	ASPH	3.0	2	30	8	LOW	35	CON	NSLOT	12.0
340	1.00	ASPH	3.0	2	30	8	LOW	35	CON	NSLOT	6.0
341	1.00	ASPH	3.0	2	30	8	LOW	35	CON	NSLOT	3.0
342	1.00	ASPH	3.0	2	30	8	LOW	35	CON	NSLOT	0.0
346	0.75	ASPH	3.0	8	24	8	LOW	35	CON	NSLOT	12.0
347	0.75	ASPH	3.0	8	24	8	LOW	35	CON	NSLOT	0.0
348	0.75	ASPH	3.0	8	24	8	LOW	35	CON	NSLOT	14.5
349	0.75	ASPH	3.0	8	24	8	LOW	35	CON	NSLOT	12.0
350	0.75	ASPH	3.0	8	24	8	LOW	35	CON	NSLOT	0.0
351	0.75	ASPH	3.0	8	24	8	LOW	35	CON	NSLOT	3.0
352	0.75	ASPH	3.0	8	24	8	LOW	35	CON	NSLOT	6.0
353	0.75	ASPH	3.0	8	24	8	LOW	35	CON	NSLOT	9.0
354	0.75	ASPH	3.0	2	30	8	LOW	35	CON	NSLOT	9.0
355	0.75	ASPH	3.0	2	30	8	LOW	35	CON	NSLOT	6.0
356	0.75	ASPH	3.0	2	30	8	LOW	35	CON	NSLOT	3.0
357	0.75	ASPH	3.0	2	30	8	LOW	35	CON	NSLOT	0.0
358	0.75	ASPH	3.0	2	30	8	LOW	35	CON	NSLOT	14.5
359	0.75	ASPH	3.0	2	30	8	LOW	35	CON	NSLOT	12.0
360	0.75	SPH	3.4	8	24	8	LOW	35	CON	NSLOT	12.0
361	0.75	SPH	3.4	8	24	8	LOW	35	CON	NSLOT	14.5
362	0.75	SPH	3.4	8	24	8	LOW	35	CON	NSLOT	9.0
363	0.75	SPH	3.4	8	24	8	LOW	35	CON	NSLOT	6.0
364	0.75	SPH	3.4	8	24	8	LOW	35	CON	NSLOT	3.0
365	0.75	SPH	3.4	8	24	8	LOW	35	CON	NSLOT	0.0

SPH = SPHERICAL
 ASPH = ASPHERICAL
 HI = HIGH
 CON = CONICAL
 HEX = HEXAGONAL
 SLOT = SLOTTED

NSLOT = UNSLOTTED
 EXTR = EXTRACTOR
 NO. = NUMBER
 IN. = INCHES
 DIAM = DIAMETER
 DEG = DEGREES
 POS = POSITION

TABLE 4
INCLINATION OF THE DEAD ZONE BOUNDARY

EXTRACTOR DIAMETER (INCHES)	BASE ANGLE (DEGREES)	DEAD ZONE BOUNDARY INCLINATION (DEGREES)	BOUNDARY INCLINATION AS A MULTIPLE OF BASE ANGLE
8	15	45	3.0
5	15	42	2.8
8	25	50	2.0
5	25	45	1.8
8	35	55	1.6
5	35	47	1.3
8	45	62	1.4
5	45	60	1.3

TABLE 5
TRIALS WITH EFFECTS IN RADIAL,
ANGULAR, AND CIRCUMFERENTIAL VELOCITIES

VELOCITIES NOT GREATER THAN ZERO DURING TRIAL	TRIALS WITH VELOCITIES GENERALLY GREATER THAN ZERO THROUGHOUT TRIAL				TRIALS WITH VELOCITIES ONLY GREATER THAN ZERO NEAR END OF TRIAL			
10	16	17	18	22	11	12	20	21
26	24	27	28	32	23	25	29	30
104	33	35	41	42	31	34	38	44
203	43	47	48	59	45	46	61	65
205	60	62	63	64	66	70	74	80
	68	69	72	73	81	88	89	90
	75	78	79	82	98	102	110	112
	84	86	87	91	129	133	135	202
	92	93	95	99	206	207	208	210
	103	105	107	108	212	213	300	303
	109	113	114	122	304	307	315	316
	124	125	126	128	320	321	323	325
	130	131	132	134	326	330	334	336
	201	204	211	301	337	340	354	355
	305	306	308	309	359			
	310	312	313	314				
	317	322	327	328				
	329	331	332	333				
	338	339	341	342				
	343	344	346	348				
	349	350	351	352				
	353	356	357	358				
	360	361	362	363				
	364	365						

TABLE 6
MAXIMUM PEBBLE VELOCITIES

TRIAL NUMBER	MAXIMUM PEBBLE AXIAL VELOCITY (IN./MIN)	* AXIAL POSITION OF PEBBLE IN BED (IN.)	MAXIMUM PEBBLE RESULTANT VELOCITY (IN./MIN)	* AXIAL POSITION OF PEBBLE IN BED (IN.)
10	2.4	3.8	2.4	3.8
11	1.1	25.7	2.4	-3.2
12	1.1	7.9	2.3	-1.2
16	16.5	24.1	16.5	24.1
17	1.1	9.4	1.1	9.4
18	1.1	2.1	12.9	2.1
20	12.0	-4.2	12.0	-4.2
21	7.7	-4.6	7.9	-4.6
22	3.9	-3.5	4.6	-3.5
23	4.4	-5.0	5.3	-5.0
24	1.1	0.2	1.7	-3.3
25	3.2	-3.4	3.2	-3.4
26	1.1	4.6	1.1	4.6
27	1.1	2.4	1.8	-1.9
28	1.7	0.6	1.8	0.6
29	6.9	0.8	8.8	0.8
30	1.1	3.7	1.4	3.2
31	1.1	6.3	2.3	3.7
32	3.0	-5.0	3.8	-5.0
33	1.1	22.1	1.5	3.6
34	1.1	11.7	1.4	-4.2
35	4.4	11.0	4.4	11.0
38	2.3	0.8	2.3	0.8
41	1.1	-1.3	1.1	-1.3
42	1.1	19.6	2.0	9.0
43	1.1	27.2	1.1	0.3
44	3.3	6.7	7.0	3.9
45	2.4	7.7	4.5	7.7
46	1.1	9.9	1.4	3.7
47	12.6	-1.4	13.1	-1.4
48	3.3	-5.7	5.9	-5.7
59	1.2	18.2	2.4	5.7
60	3.9	5.7	4.0	5.7
61	9.9	-5.0	9.9	-5.0
62	2.1	8.3	2.2	8.3
63	5.6	1.4	5.6	1.4
64	1.2	-0.8	1.4	-0.8
65	9.6	-6.7	12.8	-6.7
66	5.9	25.5	3.1	-0.6
68	1.2	11.3	1.2	11.3
69	1.1	3.8	1.1	3.8

TABLE 6 (Cont'd.)

70	2.7	-3.8	2.8	3.7
72	3.3	2.7	3.3	2.7
73	1.1	5.1	1.5	3.6
74	2.0	0.9	2.5	-8.4
75	1.2	8.2	1.7	8.2
78	5.1	0.6	5.1	0.6
79	0.9	6.1	1.3	2.2
80	1.1	4.8	1.2	6.5
81	2.7	-3.7	3.8	-6.9
82	1.7	-7.4	2.1	-7.4
84	7.1	-0.4	12.0	-0.4
86	2.3	0.8	2.3	0.8
87	10.5	0.3	10.5	0.3
88	2.9	-2.5	3.0	-2.5
89	1.4	11.3	1.4	8.6
90	1.1	-9.5	2.0	-9.5
91	11.1	-0.8	11.1	-0.8
92	1.2	4.4	1.5	4.4
93	1.2	7.4	1.6	3.2
95	2.0	-4.7	2.7	-4.7
98	1.1	2.9	1.4	-7.7
99	1.2	-5.1	1.2	7.6
102	3.2	-5.4	3.3	-5.4
103	7.4	-9.3	7.4	-9.3
104	7.8	26.3	7.8	26.3
105	3.3	-5.5	3.3	-5.5
107	3.2	-8.6	3.3	-8.6
108	2.7	-9.6	2.7	-9.6
109	1.8	1.2	2.1	1.2
110	2.0	3.7	2.2	3.7
112	3.0	0.5	23.0	-2.6
113	2.1	0.7	2.1	0.7
114	1.4	-6.3	1.8	-2.8
122	1.4	-1.3	1.7	-1.3
124	4.6	-1.0	7.6	-1.0
125	5.7	24.5	5.7	24.5
126	2.1	-1.8	2.1	-1.8
128	3.2	-2.0	3.2	-2.0
129	2.6	5.7	2.6	5.7
130	3.9	3.8	4.2	3.8
131	3.5	3.7	3.5	3.7
132	3.0	8.8	3.0	8.8
133	1.7	5.5	1.7	5.5
134	1.2	14.8	1.2	14.8
135	3.8	4.1	3.8	4.1
201	3.0	-1.7	3.0	-1.7
202	1.7	11.2	1.9	11.2
203	1.5	10.0	1.5	10.0
204	2.0	5.9	19.2	9.7
205	1.5	24.1	1.5	24.1
206	4.5	0.7	4.5	0.7
207	10.2	-5.8	37.8	-5.8
208	4.2	-6.5	4.2	-6.5
210	4.5	0.9	7.6	-7.0
211	3.2	-6.7	3.2	-6.7
212	1.5	-0.4	1.8	-4.1
213	2.6	-5.1	2.6	-5.1
300	1.1	3.8	1.1	3.8

TABLE 6 (Cont'd.)

301	4.4	8.4	4.4	8.4
303	3.8	-6.9	4.9	-6.9
304	3.8	24.2	3.8	24.2
305	1.2	4.5	1.2	4.5
306	2.9	-5.0	2.9	-5.0
307	1.2	12.9	1.6	6.3
308	1.5	13.1	3.0	-1.7
309	3.2	-3.4	3.2	-3.4
310	3.2	-6.6	3.7	-6.6
312	1.8	2.0	1.9	2.0
313	1.4	-2.3	1.5	3.4
314	3.2	13.3	14.7	-3.1
315	1.7	3.6	7.2	2.0
316	2.0	15.0	16.3	-3.6
317	1.4	4.7	1.4	21.2
320	4.8	-5.7	5.0	-5.7
321	6.5	6.8	6.5	6.8
322	1.7	5.9	1.9	5.9
323	6.6	-5.0	6.6	-5.0
325	5.6	-5.2	5.6	-5.2
326	1.5	24.7	7.3	4.1
327	1.5	2.2	1.8	1.7
328	6.2	-6.9	24.1	0.5
329	1.4	-4.7	2.9	-0.9
330	2.0	-2.5	2.1	-2.5
331	1.5	12.9	1.5	12.9
332	1.7	2.7	1.7	2.7
333	7.7	5.6	7.9	5.6
334	4.5	13.3	4.5	13.3
336	1.4	5.4	3.8	-2.8
337	1.2	8.1	1.2	8.1
338	5.9	-7.7	5.9	-7.7
339	1.7	-1.6	1.7	-1.6
340	3.5	-4.2	3.5	-4.2
341	2.6	3.7	2.6	3.7
342	2.4	-2.1	3.1	-2.1
343	5.4	-4.3	5.8	-4.3
344	4.4	-2.7	4.5	-2.7
346	1.1	-3.5	1.1	21.3
348	0.9	-4.4	1.9	-4.4
349	2.4	-5.4	3.0	-5.4
350	2.1	-1.7	2.6	-1.7
351	3.5	-6.7	3.6	-6.7
352	2.9	-7.4	2.9	-7.4
353	1.5	-1.4	1.7	-1.4
354	2.6	-4.9	2.6	-4.9
355	3.5	-4.5	3.5	-4.5
356	3.3	-8.8	3.5	-8.8
357	2.7	-1.9	3.3	7.8
358	1.1	-2.4	28.3	1.2
359	4.1	-7.5	4.1	-7.5
360	2.7	-7.0	2.8	-7.0
361	1.2	0.9	1.2	0.9
362	3.8	-5.8	3.8	-5.8
363	3.5	-4.8	4.3	-4.8
364	3.3	-8.6	3.3	-8.6
365	3.6	-3.8	6.0	1.4

* THE AXIAL POSITION OF THE PEBBLE IN THE BED IS
 MEASURED UPWARDS FROM THE TOP OF THE VESSEL BASE.
 NEGATIVE PEBBLE POSITIONS ARE BELOW THE VESSEL BASE.
 IN. = INCHES
 MIN = MINUTE

TABLE 7

INFLUENCE OF EXTRACTOR ON PEBBLE MOVEMENT

TRIAL NO.	CIRCUM ABSOLUTE VELOCITY RANGE (POWER OF 10)	CIRCUM VELOCITY START HEIGHT	LOCATION OF MAJORITY OF CIRCUM VELOCITIES	EXTR POS
10			NIL	LOW
11	+01	+ 3	BASE	LOW
12	+01	+ 5	BASE	LOW
16	+01	+21	SCATTERED	LOW
17	+00	+27	SCATTERED	LOW
18	+01	+28	SCATTERED	LOW
20	+01	+14	BASE	LOW
21	+00	+13	BASE	LOW
22	+00	+26	BASE	LOW
23	+00	+11	BASE	LOW
24	+00	+ 2	BASE	LOW
25	+00	+11	BASE	LOW
26			NIL	LOW
27	+00	+ 0	BASE	LOW
28	+00	+ 1	BASE	LOW
29	+01	+16	BASE	LOW
30	+01	+ 3	BASE	LOW
31	+01	+ 4	BASE	LOW
32	+00	+26	BASE	LOW
33	+00	+24	TOP	LOW
34	+00	+ 2	BASE	LOW
35	+00	+26	SCATTERED	LOW
38	+00	+ 2	BASE	HI
41	+00	+ 9	SCATTERED	HI
42	+00	+28	SCATTERED	HI
43	+00	+12	BASE	HI
44	+01	+19	BASE	HI
45	+01	+13	BASE	HI
46	+00	+10	BASE	HI
47	+01	+19	BASE	HI
48	+01	+21	BASE	HI
59	+01	+27	BASE	LOW
60	+00	+28	SCATTERED	LOW
61	+00	+15	BASE	LOW
62	+00	+30	SCATTERED	LOW
63	+00	+30	SCATTERED	LOW
64	+00	+30	TOP	LOW
65	+01	+ 6	BASE	LOW
66	+01	+ 4	BASE	LOW
68	+00	+26	SCATTERED	LOW
69	+00	+ 4	SCATTERED	LOW

TABLE 7 (Cont'd.)

70	+01	+17	SCATTERED	LOW
72	+01	+26	SCATTERED	LOW
73	+01	+26	SCATTERED	LOW
74	+00	+ 4	BASE	LOW
75	+00	+30	SCATTERED	LOW
78	+00	+19	SCATTERED	HI
79	+01	+27	SCATTERED	HI
80	+00	+ 6	BASE	HI
81	+01	+ 3	BASE	HI
82	+00	+24	BASE	HI
84	+01	+24	BASE	HI
86	+00	+18	BASE	LOW
87	+00	+29	SCATTERED	LOW
88	+00	+13	BASE	LOW
89	+00	+ 9	BASE	LOW
90	+00	+ 2	BASE	LOW
91	+00	+25	SCATTERED	LOW
92	+00	+30	SCATTERED	LOW
93	+00	+29	SCATTERED	HI
95	+00	+30	BASE	HI
98	+00	+ 6	BASE	HI
99	-01	+28	SCATTERED	HI
102	+00	- 5	BASE	LOW
103	+01	+20	SCATTERED	LOW
104			NIL	LOW
105	+00	+27	SCATTERED	LOW
107	+00	+23	BASE	LOW
108	+00	+30	BASE	LOW
109	+00	+28	BASE	LOW
110	+00	+ 4	BASE	LOW
112	+02	+ 7	BASE	LOW
113	+00	+29	BASE	LOW
114	+00	+25	SCATTERED	LOW
122	+00	+30	SCATTERED	LOW
124	+01	+24	BASE	LOW
125	+00	+27	BASE	LOW
126	+00	+28	SCATTERED	LOW
128	+00	+27	SCATTERED	LOW
129	+00	+21	BASE	LOW
130	+01	+30	SCATTERED	LOW
131	+01	+27	SCATTERED	LOW
132	+01	+24	SCATTERED	LOW
133	+00	+14	SCATTERED	LOW
134	+00	+25	SCATTERED	LOW
135	-01	+ 4	BASE	LOW
201	+00	+29	SCATTERED	LOW
202	+00	+11	BASE	LOW
203			NIL	LOW
204	+02	+25	BASE	LOW
205			NIL	LOW
206	-01	- 1	BASE	LOW
207	+02	+ 8	BASE	LOW
208	+01	+12	BASE	LOW
210	+01	+ 4	BASE	LOW
211	+00	+24	BASE	LOW
212	+00	+ 7	BASE	LOW
213	+00	+10	BASE	LOW
300	+00	+11	BASE	LOW

TABLE 7 (Cont'd.)

301	+00	+28	BASE	LOW
303	+01	+ 3	BASE	LOW
304	+01	+ 3	BASE	LOW
305	+00	+30	TOP	LOW
306	+00	+22	SCATTERED	LOW
307	+00	+10	BASE	LOW
308	+01	+17	BASE	LOW
309	+00	+15	BASE	LOW
310	+00	+16	BASE	LOW
312	+00	+ 2	BASE	LOW
313	-01	+20	TOP	LOW
314	+00	+23	BASE	LOW
315	+01	+ 4	BASE	LOW
316	+01	+ 3	BASE	LOW
317	+00	+21	BASE	LOW
320	+00	+ 9	BASE	LOW
321	+01	- 2	BASE	LOW
322	+00	+20	BASE	LOW
323	+00	+ 9	BASE	LOW
325	+00	+ 6	BASE	LOW
326	+01	+14	BASE	LOW
327	+00	+27	BASE	LOW
328	+02	+15	BASE	LOW
329	+00	+19	BASE	LOW
330	+00	+ 3	BASE	LOW
331	+00	+20	SCATTERED	LOW
332	-01	+21	SCATTERED	LOW
333	+01	+21	SCATTERED	LOW
334	-01	+15	SCATTERED	LOW
336	+01	+12	BASE	LOW
337	+00	+ 9	BASE	LOW
338	+00	+24	BASE	LOW
339	+00	+29	SCATTERED	LOW
340	+00	+14	BASE	LOW
341	+01	+25	BASE	LOW
342	+01	+30	BASE	LOW
343	+01	+21	BASE	LOW
344	+00	+22	SCATTERED	LOW
346	+00	+24	SCATTERED	LOW
348	+00	+21	BASE	LOW
349	+00	+23	SCATTERED	LOW
350	+00	+22	BASE	LOW
351	+00	+23	BASE	LOW
352	+01	+22	BASE	LOW
353	+00	+21	BASE	LOW
354	+00	+13	BASE	LOW
355	+00	+15	BASE	LOW
356	+00	+24	SCATTERED	LOW
357	+01	+30	SCATTERED	LOW
358	+02	+23	BASE	LOW
359	+00	+ 7	BASE	LOW
360	+00	+22	BASE	LOW
361	+00	+21	BASE	LOW
362	+00	+16	BASE	LOW
363	+01	+23	BASE	LOW
364	+01	+24	SCATTERED	LOW
365	+01	+24	BASE	LOW

NO. = NUMBER
CIRCUM = CIRCUMFERENTIAL
EXTR = EXTRACTOR
POS = POSITION

TABLE 8
TRIAL CIRCUMFERENTIAL VELOCITIES

EXTRACTOR POSITION	NUMBER OF TRIALS	CIRCUMFERENTIAL VELOCITY RANGE (POWER OF 10)	FRACTION OF TOTAL NUMBER OF TRIALS IN EACH RANGE
LOW	137	NIL	0.04
		-2 TO -1	0.04
		-1 TO 0	0.60
		0 TO +1	0.28
		+1 TO +2	0.04
HIGH	19	NIL	0.00
		-2 TO -1	0.05
		-1 TO 0	0.58
		0 TO +1	0.37
		+1 TO +2	0.00

TABLE 9
VELOCITY PROFILE DIFFERENCE

TRIAL NO.	PEBBLE SEEDING RADIUS (IN.)	PEBBLE TRANSIT NO.	DIFFERENCE OUTER - INNER ----- OUTER
11	14.5	1.05	
12	13.5	0.91	0.13
22	14.5	1.65	
21	13.5	1.38	0.16
23	14.5	1.00	
24	13.5	1.18	-0.18
27	14.5	1.10	
28	13.5	1.17	-0.06
69	14.5	1.30	
213	12.0	0.97	0.25
107	14.5	1.10	
108	14.0	1.06	0.04
300	14.5	1.16	
301	12.0	0.91	0.22
312	14.5	1.43	
313	12.0	1.00	0.30
317	14.5	1.39	
320	9.0	0.77	0.45
328	14.5	1.14	
327	12.0	0.99	0.13
329	14.5	1.31	
330	12.0	1.17	0.11
337	14.5	1.33	
339	12.0	0.93	0.30
348	14.5	1.21	
346	12.0	1.06	0.12
358	14.5	1.16	
359	12.0	1.01	0.13
361	14.5	1.42	
360	12.0	1.00	0.30

NO. = NUMBER

IN. = INCHES

(-) IN LAST COLUMN DENOTES A DECREASE IN
TRANSIT NUMBER FROM INNER SEEDING
POSITION TO WALL SEEDING POSITION.

TABLE 10
WALL CENTRE IDENTICAL GEOMETRY PAIRS

TRIAL NO.	PEBBLE SEEDING RADIUS (IN.)	PEBBLE DIAM (IN.)	PEBBLE SHAPE	PEBBLE SPECIFIC GRAVITY		PEBBLE BED HEIGHT DIAM RATIO	BASE ANGLE (DEG)	PEBBLE TRANSIT TIME (MIN)		
				CYLIND SECTION	BASE SECTION			TOTAL		
10	0.0	1.00	SPH	3.4	0.93	35	68.3	-	68.3	
11	14.5	1.00	SPH	3.4	0.93	35	61.0	6.0	67.0	
20	0.0	1.00	SPH	3.4	0.93	25	41.0	1.0	42.0	
22	14.5	1.00	SPH	3.4	0.93	25	91.7	8.0	99.7	
25	0.0	1.00	SPH	3.4	0.93	35	50.0	1.0	51.0	
23	14.5	1.00	SPH	3.4	0.93	35	64.3	7.0	71.3	
29	0.0	1.00	SPH	3.4	0.93	25	35.7	-	35.7	
30	14.5	1.00	SPH	3.4	0.93	25	152.0	6.0	158.0	
31	0.0	1.00	SPH	3.4	0.93	35	62.7	-	62.7	
32	14.5	1.00	SPH	3.4	0.93	35	85.3	10.7	96.0	
42	0.0	1.00	SPH	3.4	0.93	35	49.3	-	49.3	
41	14.5	1.00	SPH	3.4	0.93	35	78.3	7.0	85.3	
45	0.0	1.00	SPH	3.4	0.93	25	48.0	-	48.0	
46	14.5	1.00	SPH	3.4	0.93	25	98.7	5.3	104.0	
47	0.0	1.00	SPH	3.4	0.93	35	62.7	1.0	63.7	
48	14.5	1.00	SPH	3.4	0.93	35	85.0	6.3	91.3	
70	0.0	0.75	SPH	3.4	1.00	35	650.0	3.0	653.0	
69	14.5	0.75	SPH	3.4	1.00	35	992.0	158.0	1150.0	
80	0.0	0.75	SPH	3.4	1.00	25	98.3	-	98.3	
79	14.5	0.75	SPH	3.4	1.00	25	189.0	4.7	193.7	
87	0.0	0.75	SPH	3.4	1.00	25	60.3	2.4	62.7	
88	14.5	0.75	SPH	3.4	1.00	25	311.0	5.0	316.0	
93	0.0	0.75	SPH	3.4	1.00	35	94.7	-	94.7	

TABLE 10 (Cont'd.)

95	14.5	0.75	SPH	3.4	1.00	35	175.0	16.0	191.0
304	0.0	1.00	SPH	3.0	1.00	35	67.5	1.8	69.3
300	14.5	1.00	SPH	3.0	1.00	35	98.0	9.0	107.0
321	0.0	1.00	ASPH	3.4	0.80	35	46.5	0.8	47.3
317	14.5	1.00	ASPH	3.4	0.80	35	103.0	20.0	123.0
333	0.0	1.00	ASPH	3.0	0.80	35	53.7	-	53.7
329	14.5	1.00	ASPH	3.0	0.80	35	98.0	20.0	118.0
334	0.0	1.00	ASPH	3.0	1.00	35	75.7	-	75.7
337	14.5	1.00	ASPH	3.0	1.00	35	122.0	22.0	144.0
350	0.0	0.75	ASPH	3.0	0.80	35	102.0	4.0	106.0
348	14.5	0.75	ASPH	3.0	0.80	35	214.0	23.0	237.0
357	0.0	0.75	ASPH	3.0	1.00	35	122.0	3.0	125.0
358	14.5	0.75	ASPH	3.0	1.00	35	174.0	32.0	206.0
365	0.0	0.75	SPH	3.4	0.80	35	71.3	2.0	73.3
361	14.5	0.75	SPH	3.4	0.80	35	155.0	35.0	190.0

'-' IN PEBBLE TRANSIT TIME COLUMN DENOTES THAT THE TIME TO TRAVERSE THIS PARTICULAR SECTION WAS UNSEPARATED FROM THE TOTAL TIME.

SPH = SPHERICAL
 ASPH = ASPHERICAL
 NO. = NUMBER
 IN. = INCHES
 DIAM = DIAMETER
 DEG = DEGREES
 CYLIND = CYLINDRICAL
 MIN = MINUTES

TABLE 11
PEBBLE TRANSIT NUMBERS

TRIAL NO.	BASE ANGLE (DEG)	PEBBLE SEEDING RADIUS (IN.)	PEBBLE TRANSIT NO.	SEEDING INV (PEB)	EXIT INV (PEB)	BED INV (PEB)
10	35	0.0	0.66	41237	60380	28800
11	35	14.5	1.05	60516	90820	28800
12	35	13.5	0.91	90932	117260	28800
13	25	0.0	0.57	0	16160	28300
14	25	13.5	1.21	48544	82730	28300
15	25	14.5	1.24	82799	117950	28300
16	15	0.0	0.37	10601	20750	27500
17	15	13.5	4.01	20806	131208	27500
18	15	13.5	1.12	0	30700	27500
19	15	14.5	8.33	40884	269877	27500
20	25	0.0	0.65	0	18430	28300
21	25	13.5	1.38	18866	58048	28300
22	25	14.5	1.65	58145	104860	28300
23	35	14.5	1.00	51790	80650	28800
24	35	13.5	1.18	80656	114600	28800
25	35	0.0	0.75	114729	136340	28800
26	45	0.0	0.83	0	24852	29900
27	45	14.5	1.10	24899	57672	29900
28	45	13.5	1.17	57772	92608	29900
29	25	0.0	0.62	56	17610	28300
30	25	14.5	1.85	17701	69921	28300
31	35	0.0	0.81	385	23585	28800
32	35	14.5	1.12	23770	56138	28800
33	45	0.0	0.79	0	23720	29900
34	45	14.5	1.08	23861	56209	29900
35	15	0.0	0.46	0	12752	27500
36	15	14.5	2.81	0	77215	27500
37	45	0.0	0.85	0	25518	29900
38	45	14.5	1.04	25557	56673	29900
39	25	14.5	1.17	0	33218	28300
40	25	0.0	0.66	33252	51850	28300
41	35	14.5	1.12	0	32212	28800
42	35	0.0	0.70	32269	52524	28800
43	15	14.5	3.76	0	103356	27500
44	15	0.0	0.43	11068	22828	27500
45	25	0.0	0.58	0	16370	28300
46	25	14.5	1.34	16435	54252	28300
47	35	0.0	0.77	0	22232	28800
48	35	14.5	1.08	22257	53239	28800
49	45	0.0	0.81	0	24319	29900
50	45	14.5	1.00	24325	54318	29900
51	15	0.0	0.40	0	11113	27500
52	15	14.5	2.39	11213	77060	27500

TABLE 11 (Cont'd.)

53	25	14.5	1.59	0	44997	28300
54	25	14.5	2.23	44997	108010	28300
55	25	14.5	2.10	0	59477	28300
56	25	14.5	1.64	59477	105956	28300
57	25	14.5	1.74	0	49154	28300
58	25	14.5	2.65	49155	124042	28300
59	15	12.0	0.99	0	27155	27500
60	15	3.0	0.36	27750	37750	27500
61	15	9.0	0.56	38008	53355	27500
62	15	6.0	0.44	53522	65747	27500
63	35	9.0	0.71	0	22860	32100
64	35	9.0	0.74	22895	46752	32100
65	35	6.0	0.78	0	23015	29600
66	35	9.0	0.83	23168	47716	29600
67	35	12.0	0.99	47787	77115	29600
68	35	3.0	0.66	77136	96749	29600
69	35	14.5	1.30	110897	201930	70000
70	35	0.0	0.71	201981	251437	70000
71	25	14.5	1.96	0	132480	67700
72	25	0.0	0.52	132513	167615	67700
73	45	0.0	0.89	0	56206	63100
74	45	14.5	1.13	56208	129740	65100
75	15	0.0	0.41	0	27115	66000
76	15	14.5	4.72	27132	338378	66000
77	35	14.5	1.18	0	82750	70000
78	35	0.0	0.72	82770	132860	70000
79	25	14.5	1.18	0	79870	67700
80	25	0.0	0.58	79881	119360	67700
81	45	0.0	0.80	0	56482	71000
82	45	14.5	1.00	63769	134990	71000
83	15	14.5	1.56	0	102940	66000
84	15	0.0	0.38	102950	128348	66000
85	35	0.0	0.59	0	41235	70000
86	35	14.5	1.59	41242	152510	70000
87	25	0.0	0.37	0	25340	67700
88	25	14.5	1.85	25432	150760	67700
89	45	0.0	0.80	0	53427	67000
90	45	14.5	1.24	53443	139060	69000
91	15	0.0	0.31	0	20310	66000
92	15	14.5	1.35	20323	109657	66000
93	35	0.0	0.52	0	36367	70000
94	35	14.5	1.95	36381	172660	70000
95	35	14.5	1.10	0	76730	70000
96	25	14.5	3.15	0	213461	67700
97	25	0.0	0.42	213477	241575	67700
98	45	14.5	1.23	0	87610	71000
99	45	0.0	0.74	87624	140285	71000
100	15	14.5	11.23	0	741085	66000
101	15	0.0	0.29	741108	760295	66000
102	45	0.0	0.70	0	49886	71000
103	45	1.0	0.73	53467	104980	71000
104	45	2.0	0.75	105012	158282	71000
105	45	3.0	0.75	158311	211370	71000
106	45	4.0	0.77	211377	265960	71000
107	45	14.5	1.10	265964	344290	71000
108	45	14.0	1.06	344320	419870	71000
109	45	13.0	0.98	419900	489401	71000
110	45	12.0	0.95	489440	557140	71000

TABLE 11 (Cont'd.)

111	45	11.0	0.91	557167	621440	71000
112	45	5.0	0.79	621474	677307	71000
113	45	6.0	0.81	677337	734600	71000
114	45	7.0	0.81	734619	792480	71000
115	45	8.0	0.84	792514	852160	71000
120	15	14.5	2.27	0	150100	66000
121	15	14.0	1.62	0	107010	66000
122	15	13.0	1.11	0	73330	66000
123	15	12.0	1.04	0	68595	66000
124	15	11.0	0.56	0	36970	66000
125	15	10.0	0.56	0	36760	66000
126	15	9.0	0.43	0	28630	66000
127	15	8.0	0.38	0	25400	66000
128	15	7.0	0.37	0	24550	66000
129	15	6.0	0.34	0	22400	66000
130	15	5.0	0.32	0	21230	66000
131	15	4.0	0.32	0	21200	66000
132	15	3.0	0.32	0	21000	66000
133	15	2.0	0.32	0	20850	66000
134	15	1.0	0.31	0	20140	66000
135	15	0.0	0.30	0	19890	66000
136	25	14.5	3.78	0	248385	65700
137	25	14.0	2.16	0	146400	67700
138	25	13.0	1.86	0	126000	67700
201	35	0.0	0.67	0	46650	70000
202	35	1.0	0.69	46696	95300	70000
203	35	2.0	0.73	95300	146250	70000
204	35	3.0	0.75	146264	198720	70000
205	35	4.0	0.74	198757	250360	70000
206	35	5.0	0.73	0	51230	70000
207	35	6.0	0.79	51243	106680	70000
208	35	7.0	0.82	106695	163800	70000
209	35	8.0	0.83	163830	221670	70000
210	35	9.0	0.83	221680	279520	70000
211	35	10.0	0.90	279533	342550	70000
212	35	11.0	0.92	342563	407220	70000
213	35	12.0	0.97	407235	475070	70000
214	35	13.0	1.11	475085	552870	70000
215	35	14.0	1.07	552880	627930	70000
300	35	14.5	1.16	0	35250	30500
301	35	12.0	0.91	35250	63095	30500
302	35	6.0	0.77	63095	86514	30500
303	35	9.0	0.83	86515	111843	30500
304	35	0.0	0.73	111845	134231	30500
305	35	3.0	0.74	134231	156775	30500
306	35	0.0	0.56	0	14829	26600
307	35	3.0	0.47	14831	27463	26600
308	35	6.0	0.62	27499	44113	26600
309	35	9.0	0.68	44113	62107	26600
310	35	12.0	0.98	134900	160943	26600
311	35	14.5	1.38	160946	197583	26600
312	35	14.5	1.43	0	37910	26600
313	35	12.0	1.00	37910	64403	26600
314	35	9.0	0.73	64700	84000	26600
315	35	6.0	0.55	84000	98700	26600
316	35	3.0	0.60	98700	114600	26600
317	35	14.5	1.39	0	41050	29500
318	35	12.0	1.17	0	34556	29500

TABLE 11 (Cont'd.)

320	35	9.0	0.77	75571	98186	29500
321	35	0.0	0.60	98188	115830	29500
322	35	3.0	0.61	115830	133849	29500
323	35	3.0	0.70	133850	158525	35000
324	35	0.0	0.74	158525	184396	35000
325	35	6.0	0.77	184398	211351	35000
326	35	9.0	0.80	211351	239523	35000
327	35	12.0	0.99	239523	274000	35000
328	35	14.5	1.14	274000	313880	35000
329	35	14.5	1.31	0	38518	29500
330	35	12.0	1.17	38519	73000	29500
331	35	9.0	0.69	73000	93360	29500
332	35	6.0	0.62	93360	111750	29500
333	35	0.0	0.55	126590	142850	29500
334	35	0.0	0.68	142850	166690	35000
335	35	6.0	0.75	166690	193000	35000
336	35	3.0	0.69	193000	217300	35000
337	35	14.5	1.33	217300	263950	35000
338	35	9.0	0.80	263950	292000	35000
339	35	12.0	0.93	292000	324400	35000
340	35	6.0	0.72	0	25061	35000
341	35	3.0	0.66	25061	48109	35000
342	35	0.0	0.67	48109	71733	35000
343	35	0.0	0.51	77253	92172	29500
344	35	3.0	0.51	92172	107077	29500
346	35	12.0	1.06	112320	184320	68000
347	35	0.0	0.54	184320	221190	68000
348	35	14.5	1.21	221190	303787	68000
349	35	12.0	0.95	303787	368308	68000
350	35	0.0	0.50	368308	402640	68000
351	35	3.0	0.52	402643	438277	68000
352	35	6.0	0.57	438277	476815	68000
353	35	9.0	0.69	476816	523517	68000
354	35	9.0	0.83	523520	589600	80000
355	35	6.0	0.75	589600	649356	80000
356	35	3.0	0.71	649356	706478	80000
357	35	0.0	0.72	706478	763773	80000
358	35	14.5	1.16	763773	856666	80000
359	35	12.0	1.01	856666	937800	80000
360	35	12.0	1.00	0	57736	58000
361	35	14.5	1.42	57743	140253	58000
362	35	9.0	0.72	140256	182173	58000
363	35	6.0	0.63	182173	218920	58000
364	35	3.0	0.57	218920	252180	58000
365	35	0.0	0.58	252180	285820	58000

NO. = NUMBER
 DEG = DEGREES
 IN. = INCHES
 INV = INVENTORY
 PEB = PEBBLES

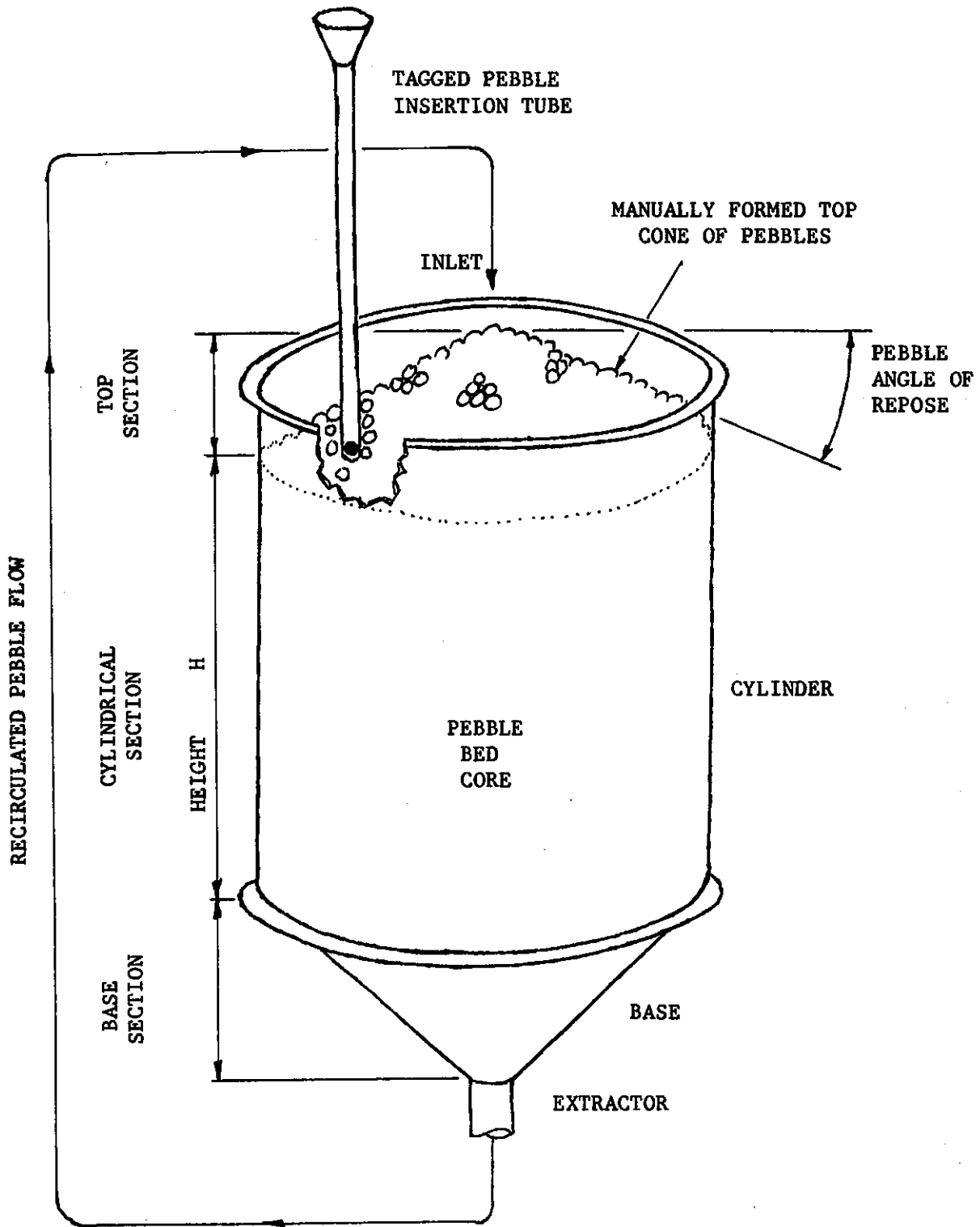
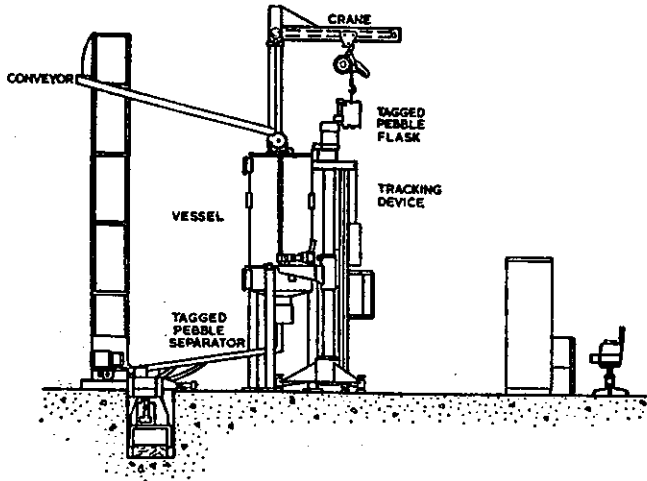
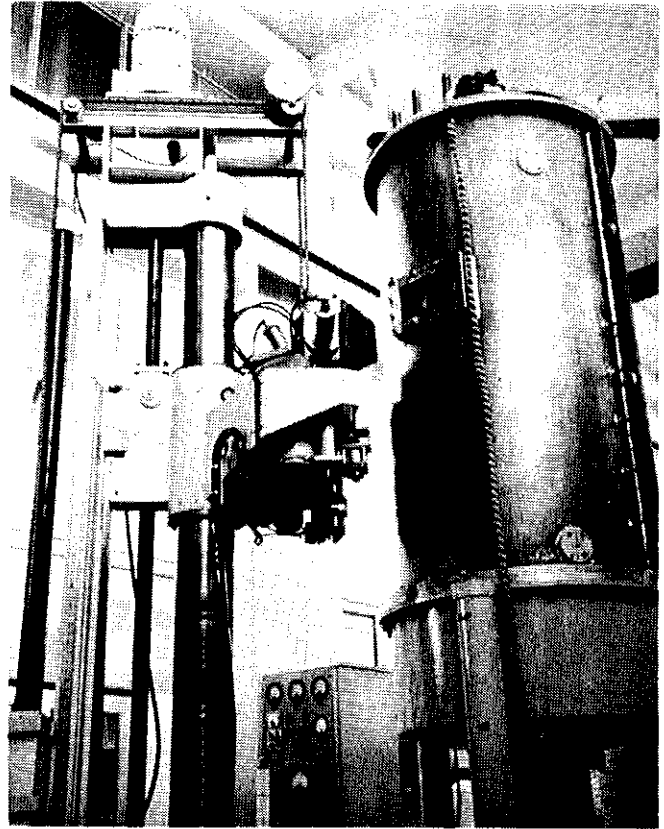

FIGURE 1. PEBBLE BED



(a) Diagrammatic View of Experimental Equipment.
(Szomanski, 1967)



(b) Vessel and Tracker

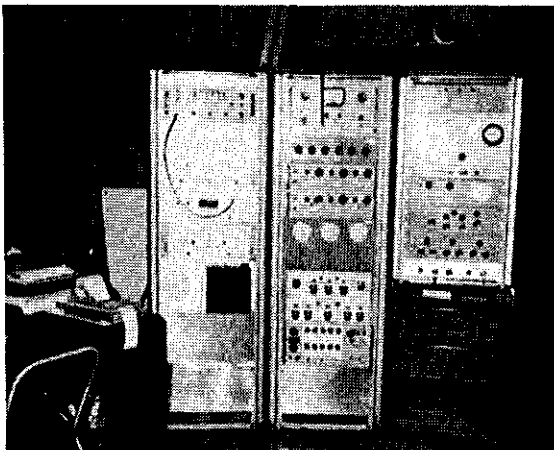

(c) Operating Console

FIGURE 2. EQUIPMENT FOR THE PEBBLE BED EXPERIMENT

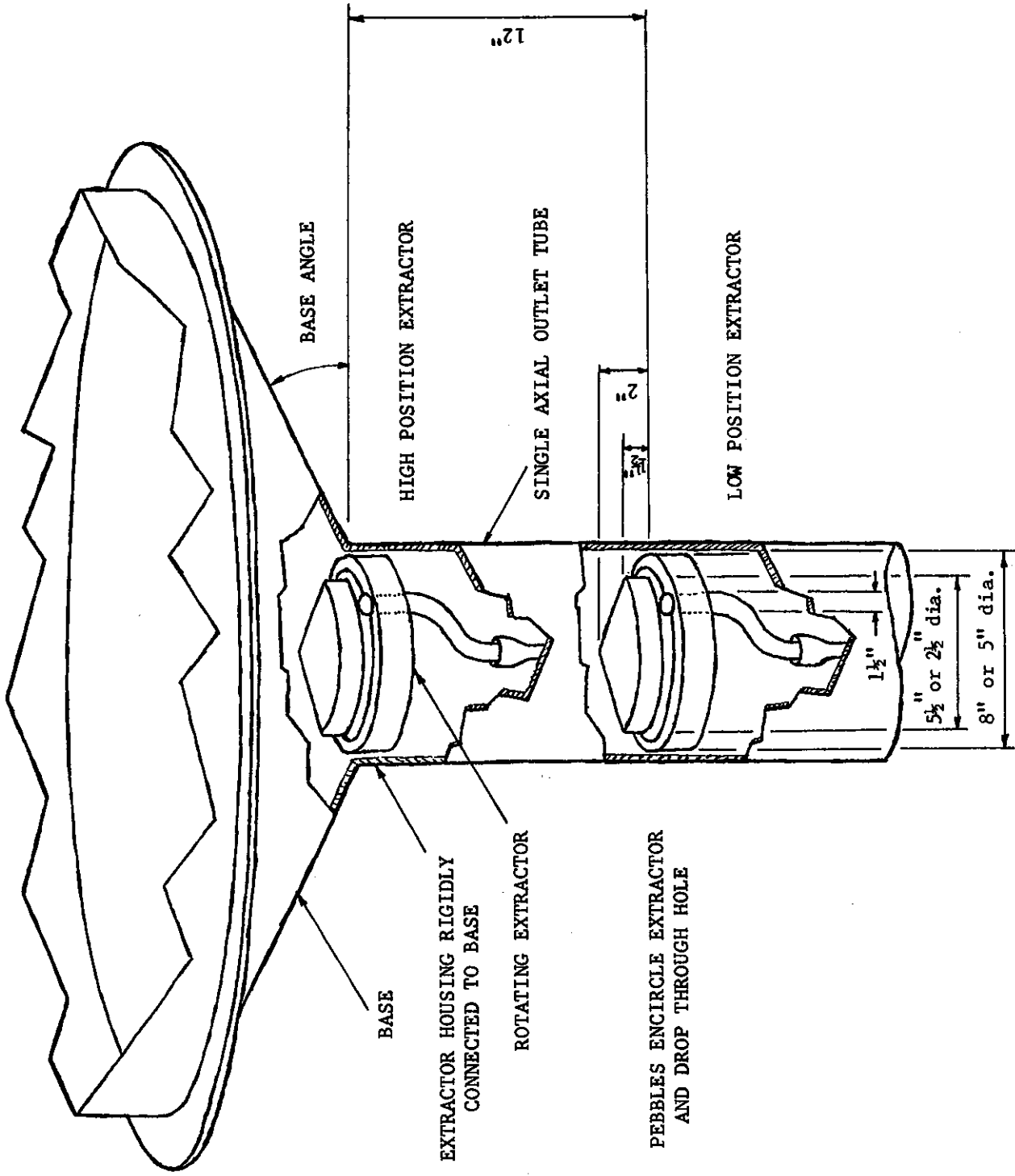

FIGURE 3. EXTRACTOR AND BASE

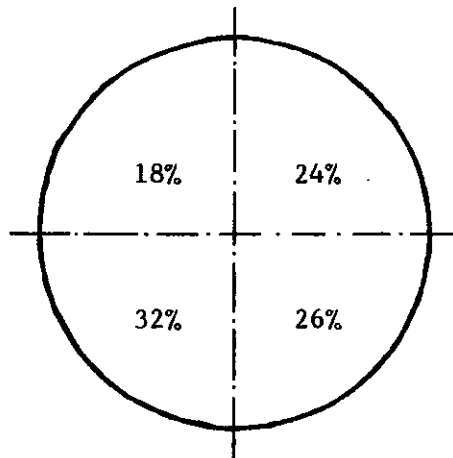

FIGURE 4. ENTRY MECHANISM PEBBLE SCATTER

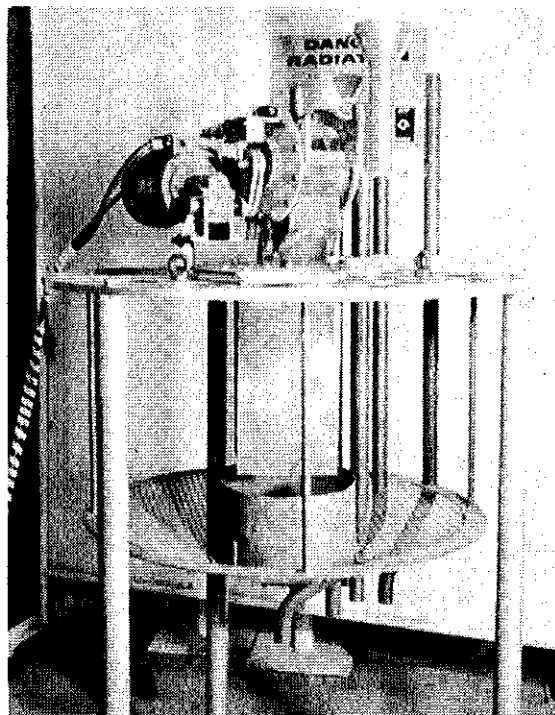
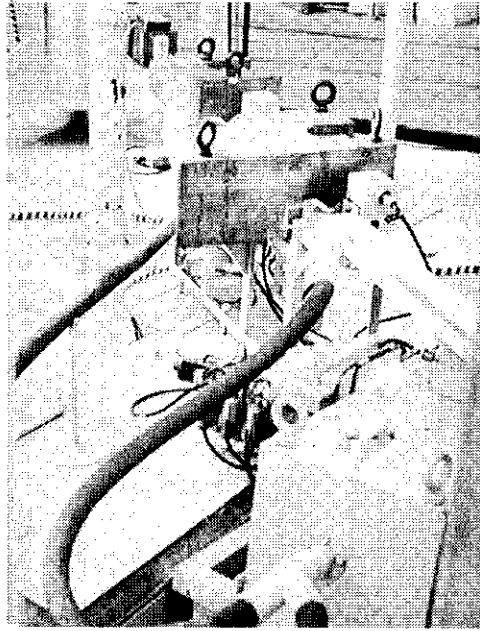
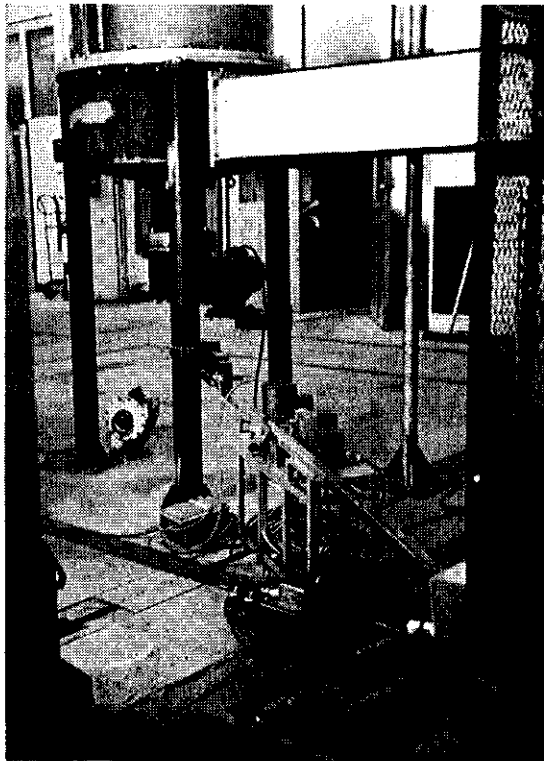

FIGURE 5. ENTRY MECHANISM AND TAGGED PEBBLE SEEDING TUBES



(a) Pebble Outlet Chute and Tagged Pebble Handling Mechanism.



(b) Lead Shielding Removed Showing Pebble Photocell Counter and Tagged Pebble Sorter.

FIGURE 6. PHOTOCCELL AND PEBBLE COUNTER

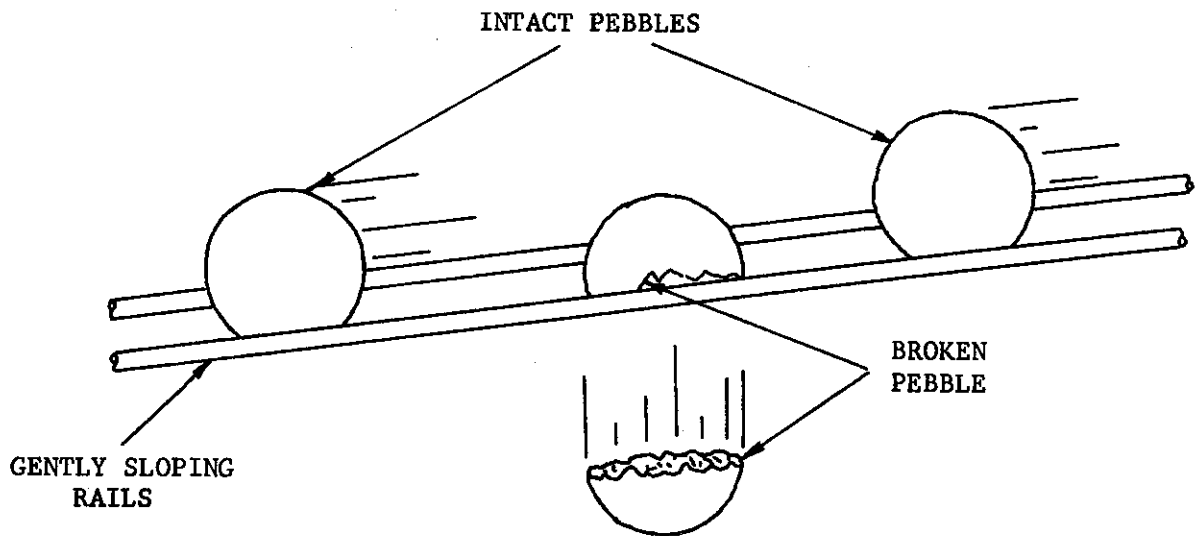

FIGURE 7. BROKEN PEBBLE SORTER

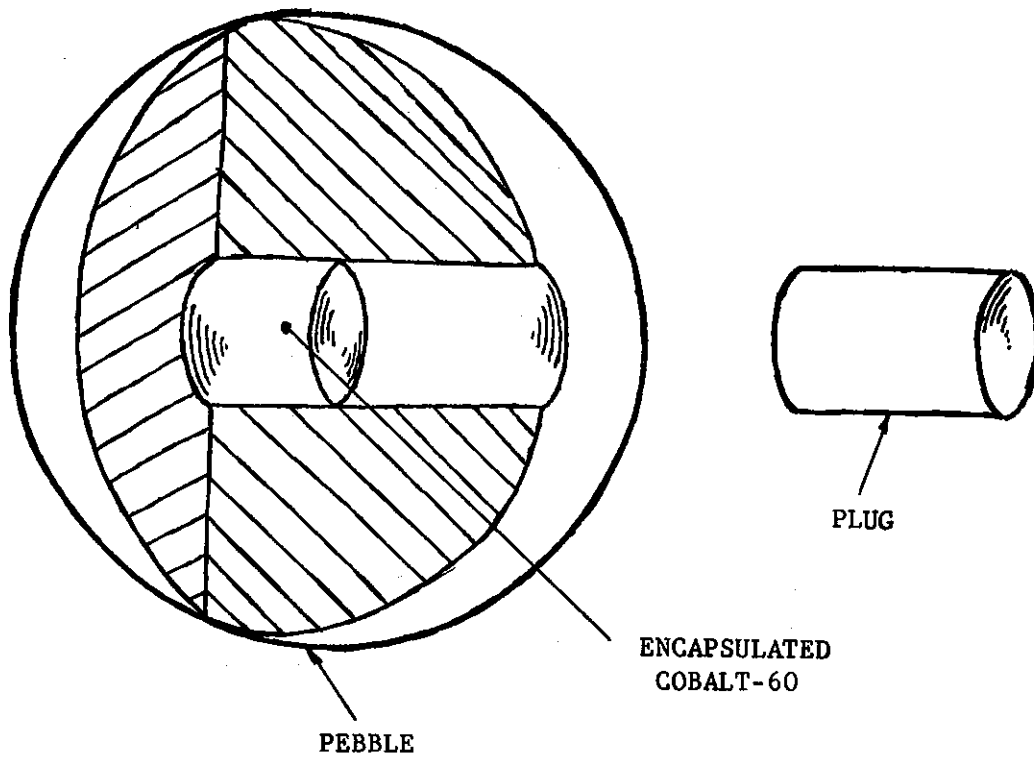

FIGURE 8. TAGGED PEBBLE

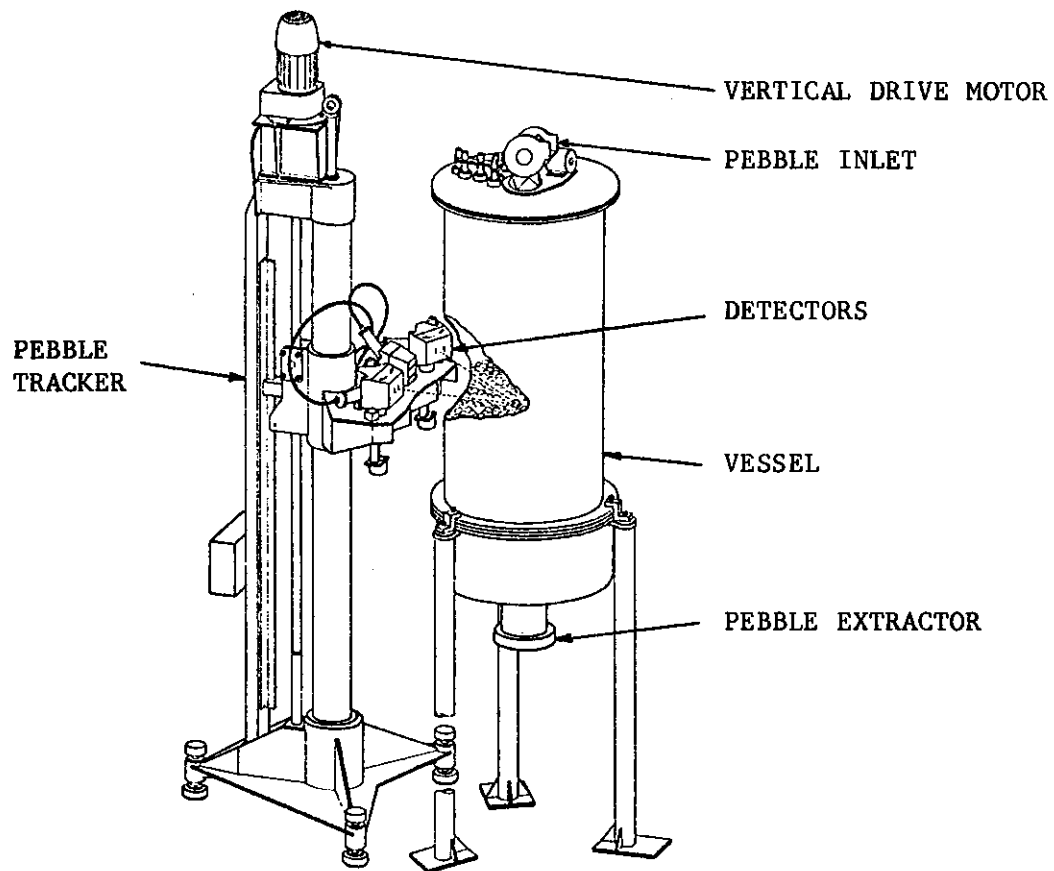

FIGURE 9. PEBBLE TRACKING DEVICE

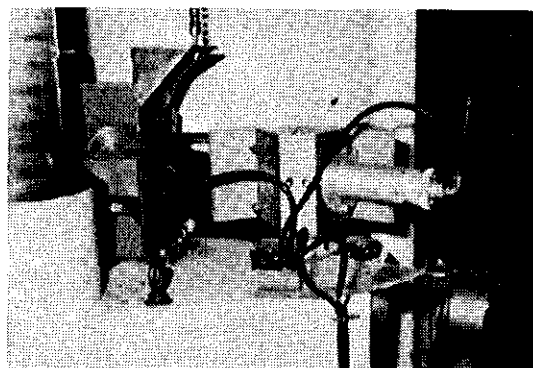
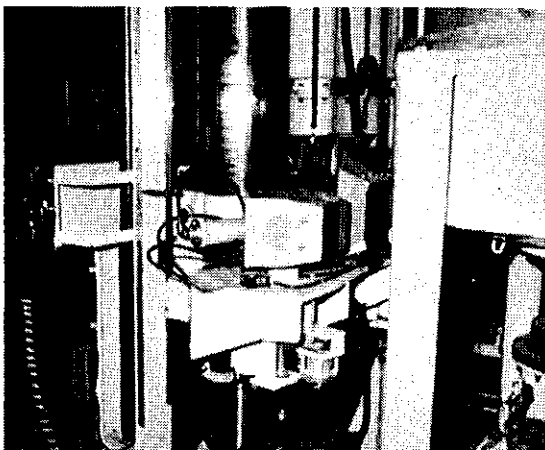
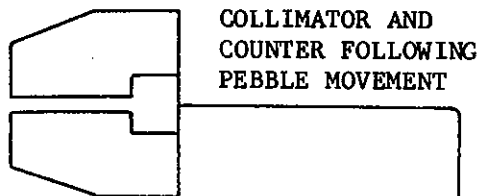
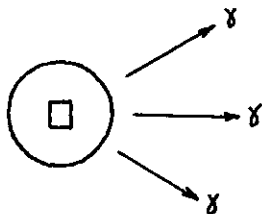

FIGURE 10. DETECTOR HEADS

COBALT-60
TAGGED
PEBBLE



VOLTAGE PROPORTIONAL TO
COLLIMATOR (OR PEBBLE) POSITION

AMPLIFIER

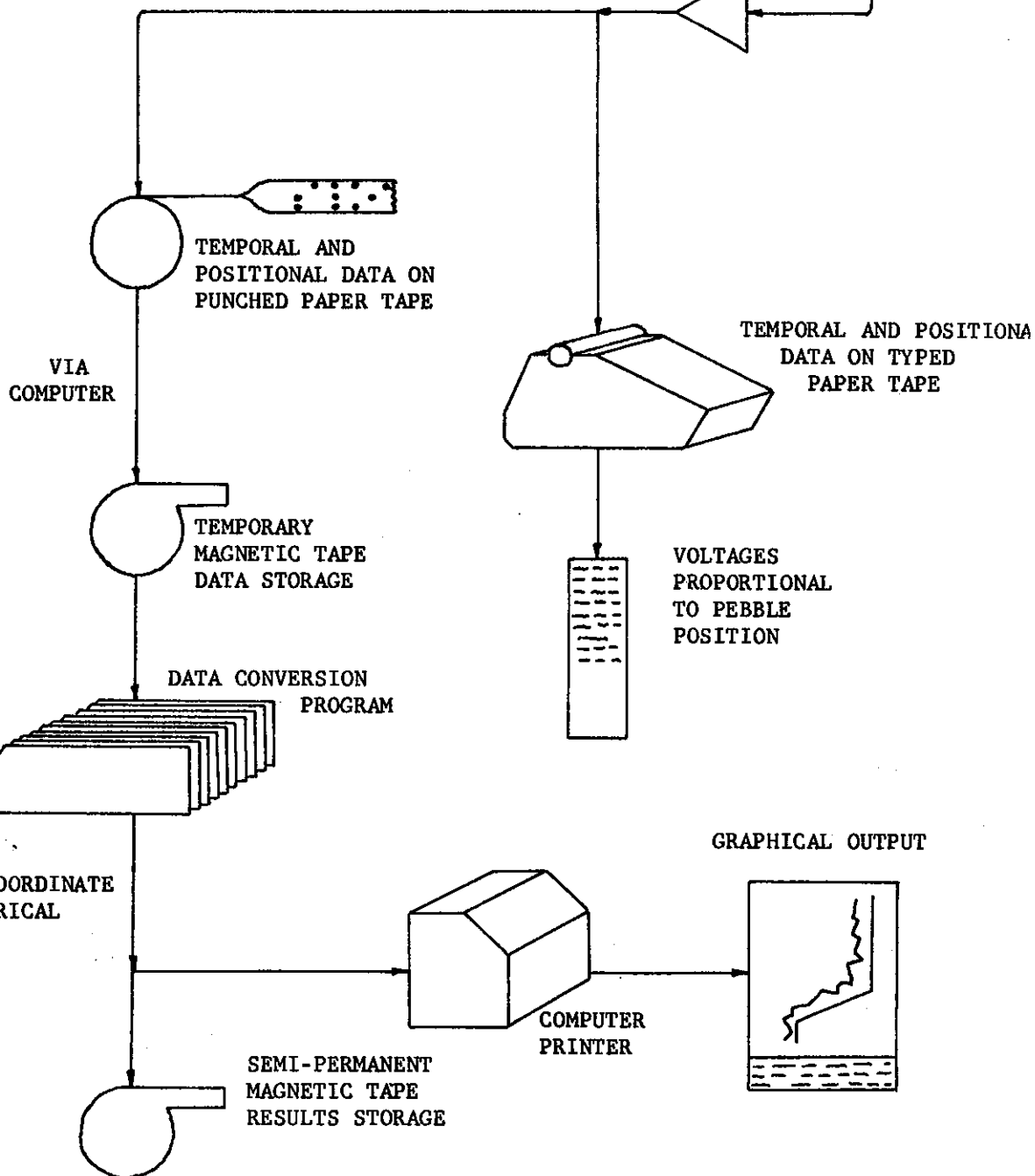

FIGURE 11. EXPERIMENTAL DATA FLOW

FIGURES 12-55
PATHS OF PEBBLES THROUGH PEBBLE BED

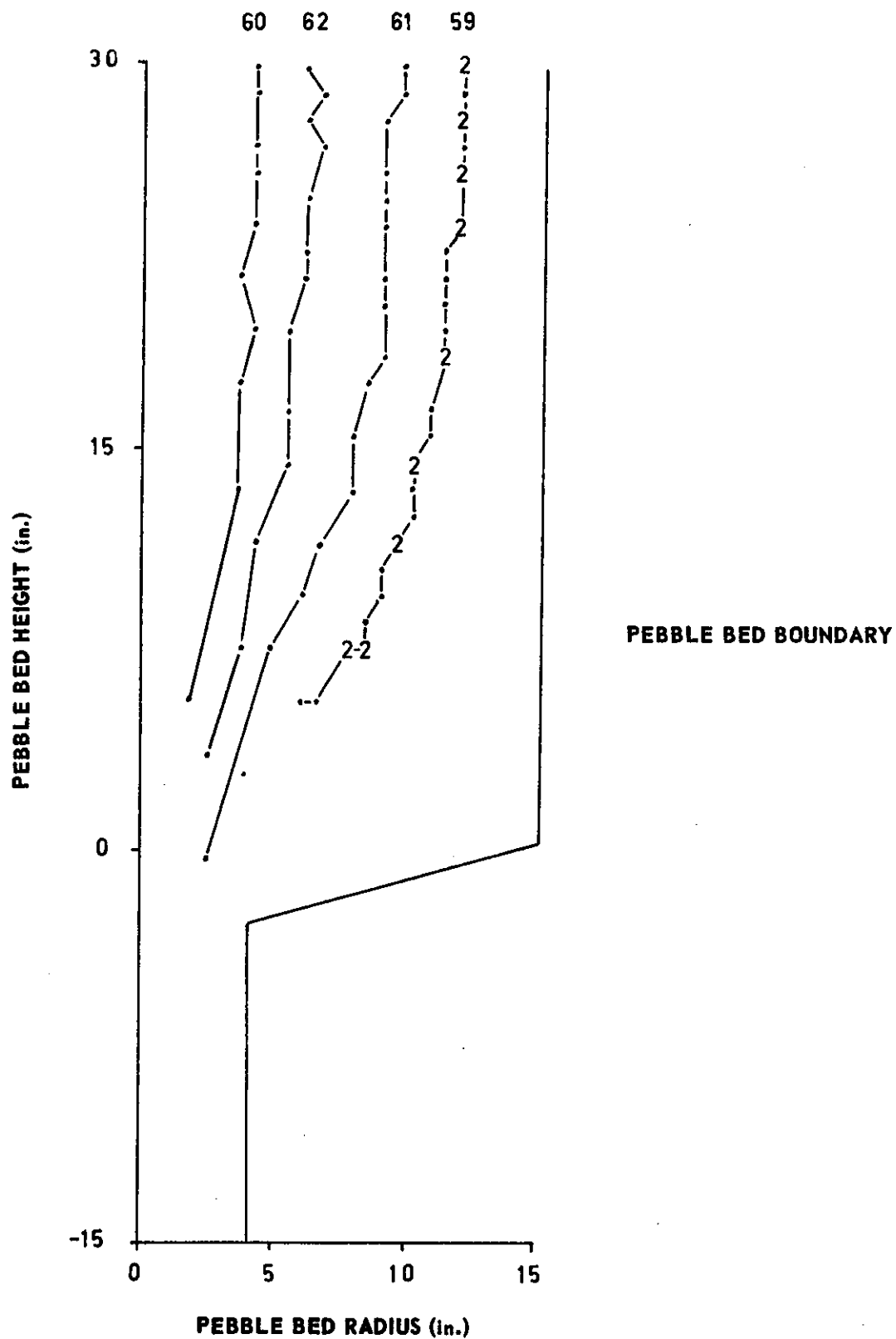

FIGURE 12. GROUP 15.

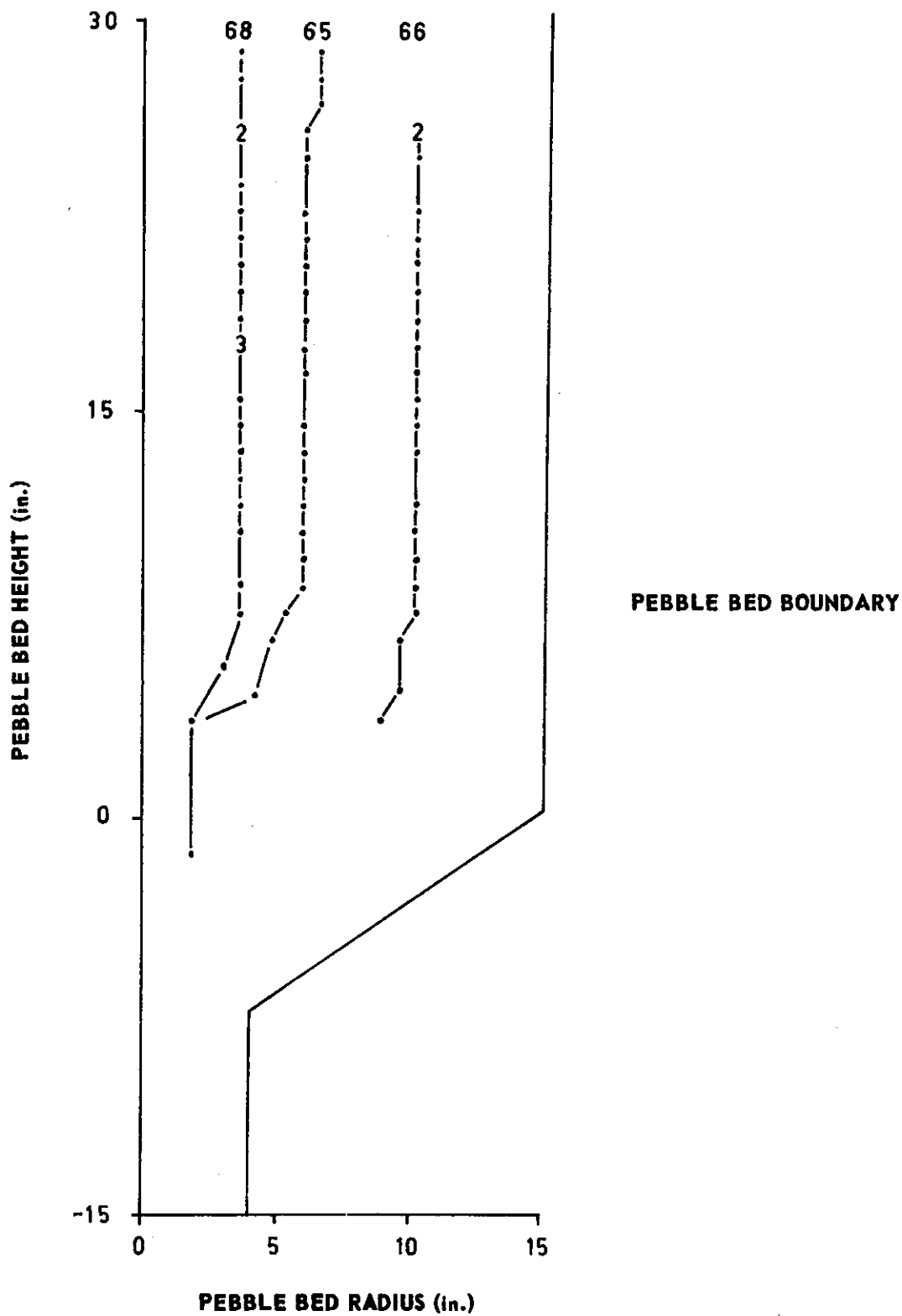

FIGURE 13. GROUP 17.

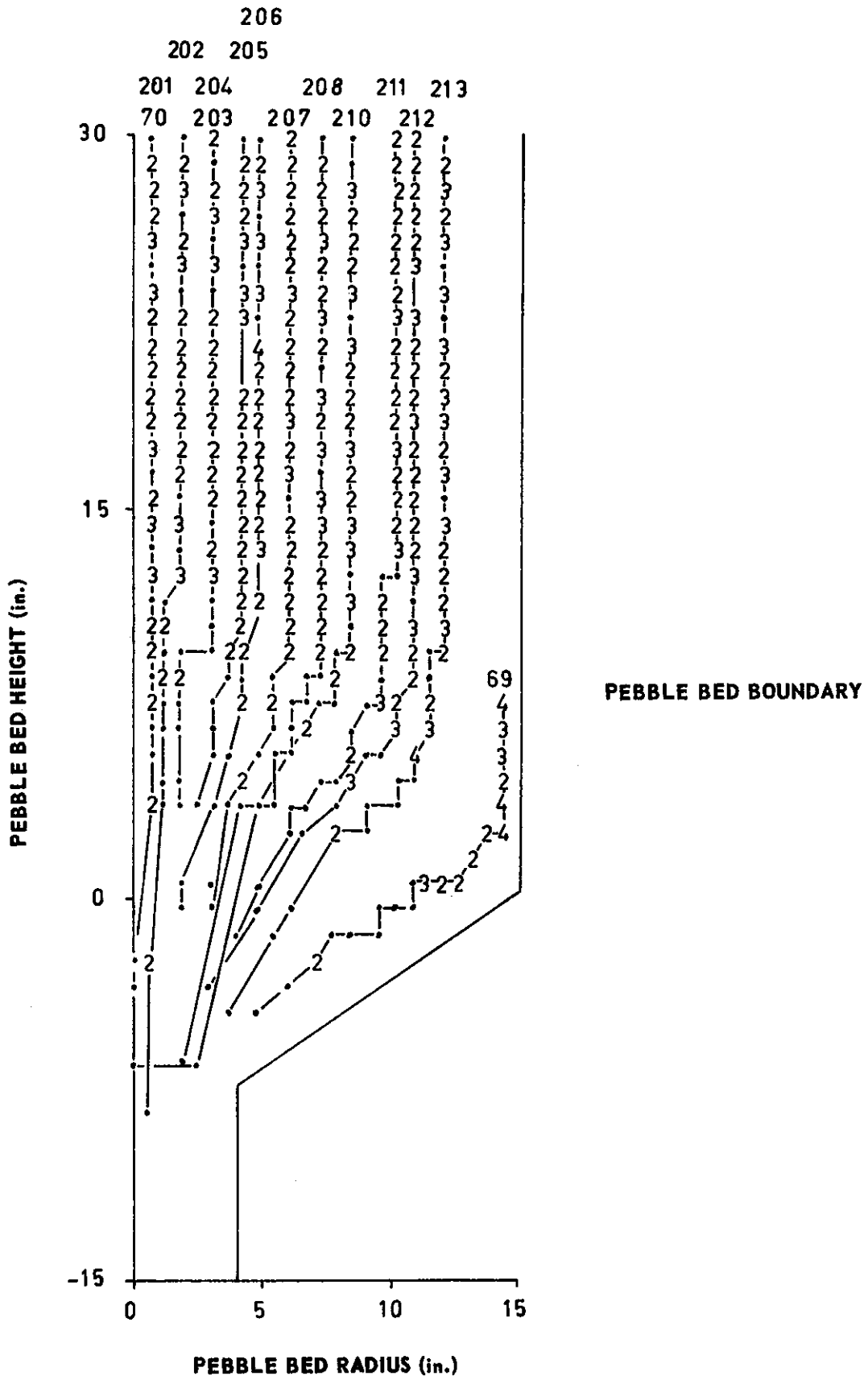

FIGURE 14. GROUP 18.

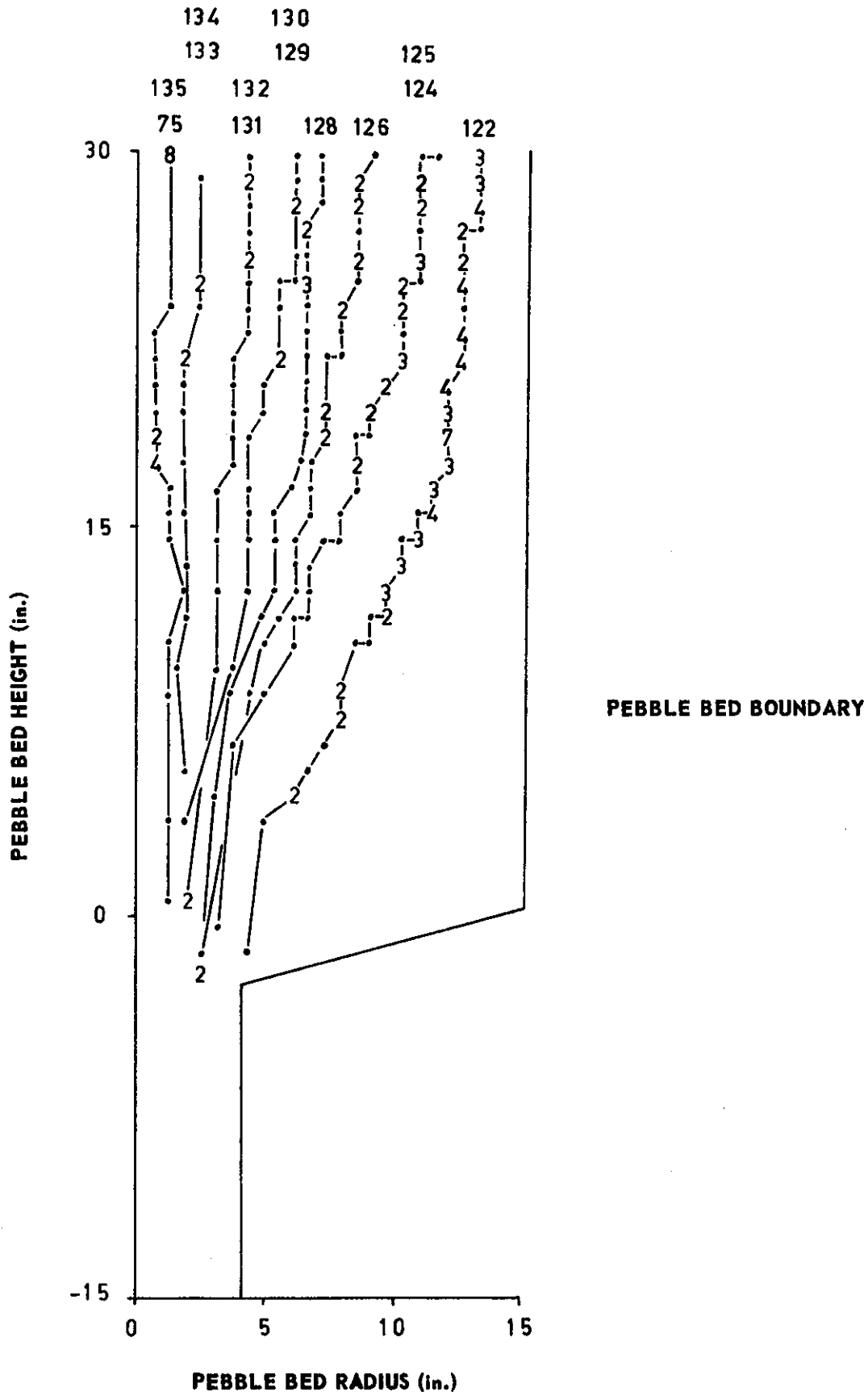

FIGURE 15. GROUP 22.

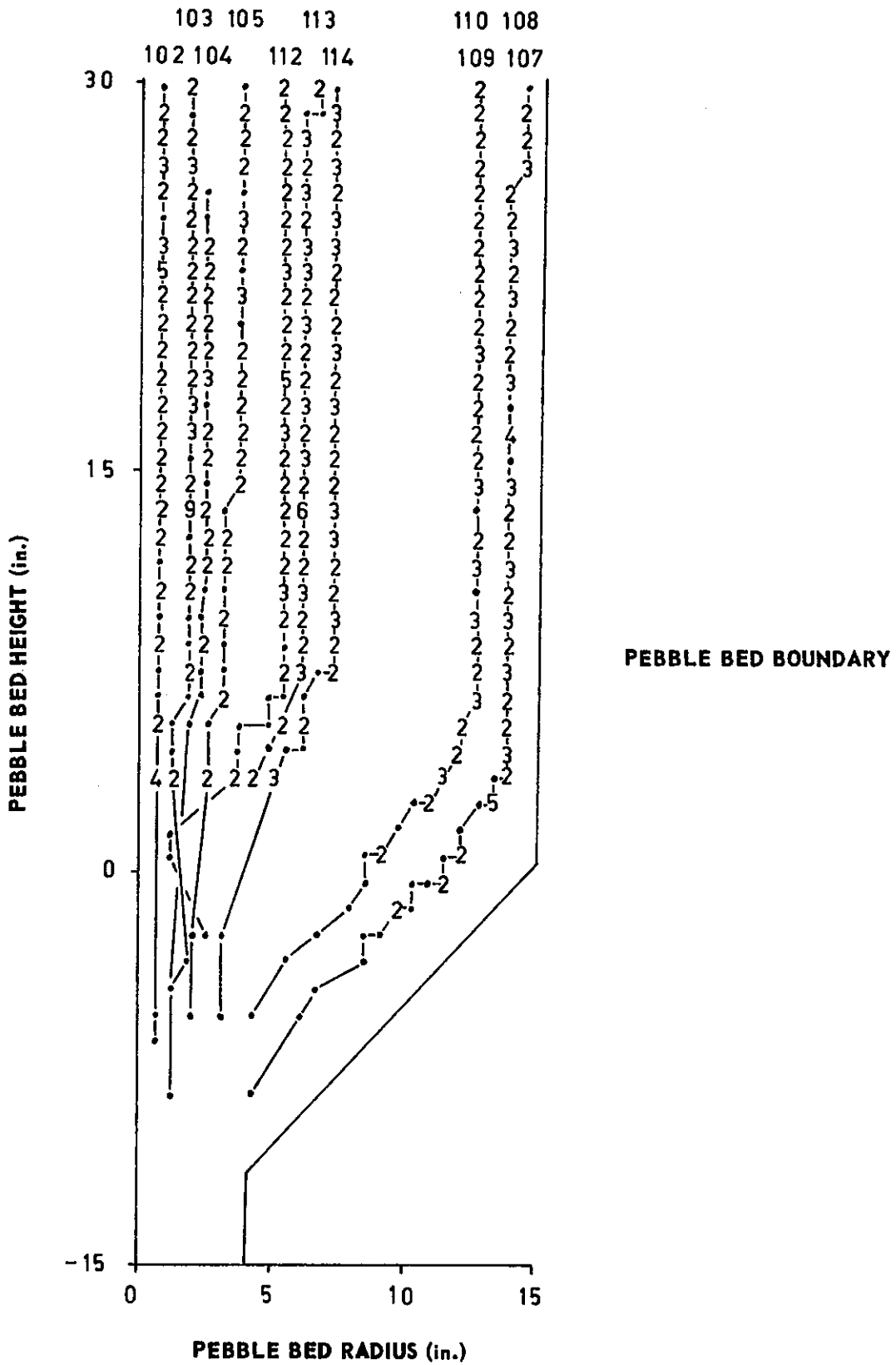

FIGURE 16. GROUP 34.

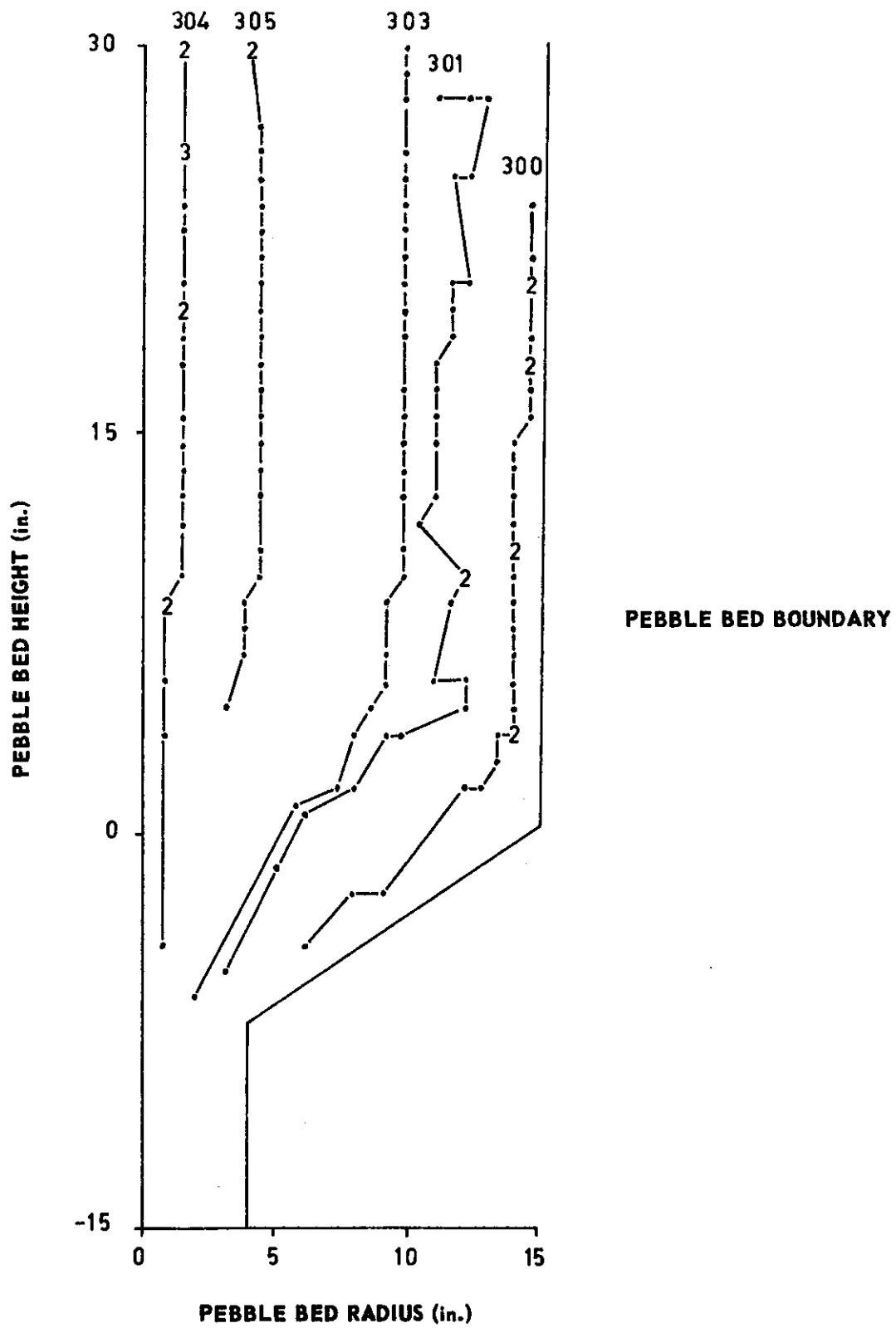

FIGURE 17. GROUP 35.

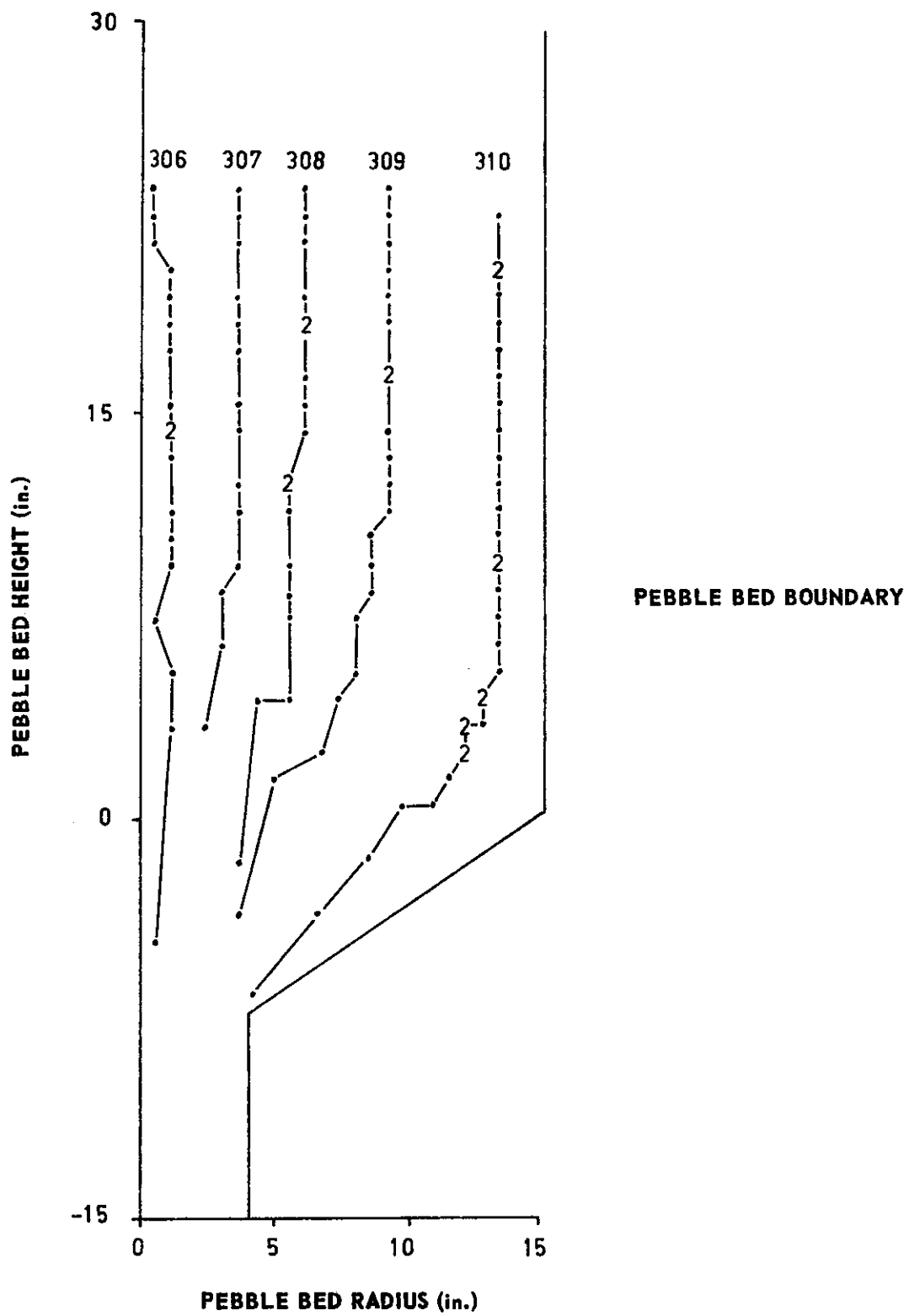

FIGURE 18. GROUP 36.

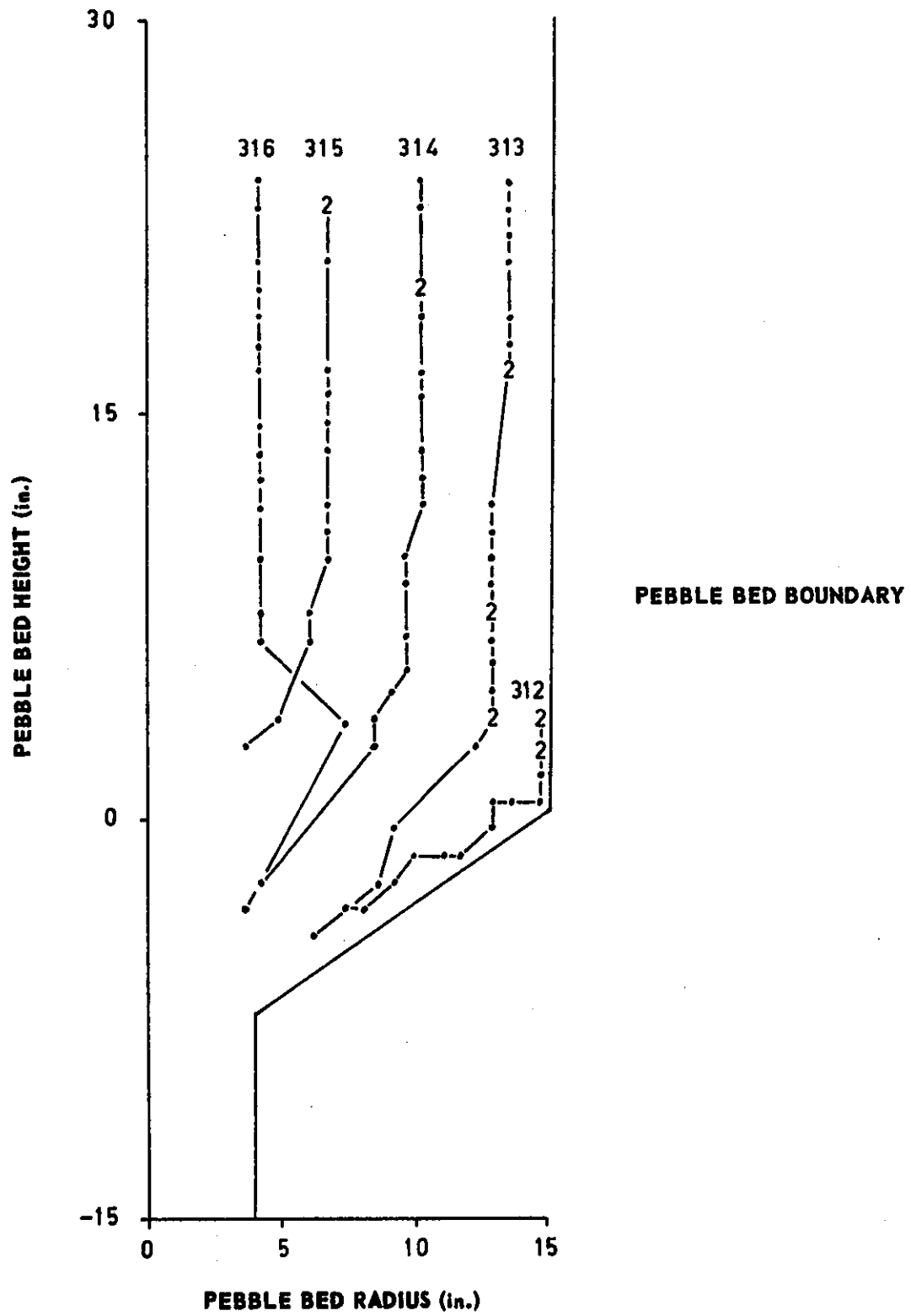

FIGURE 19. GROUP 37.

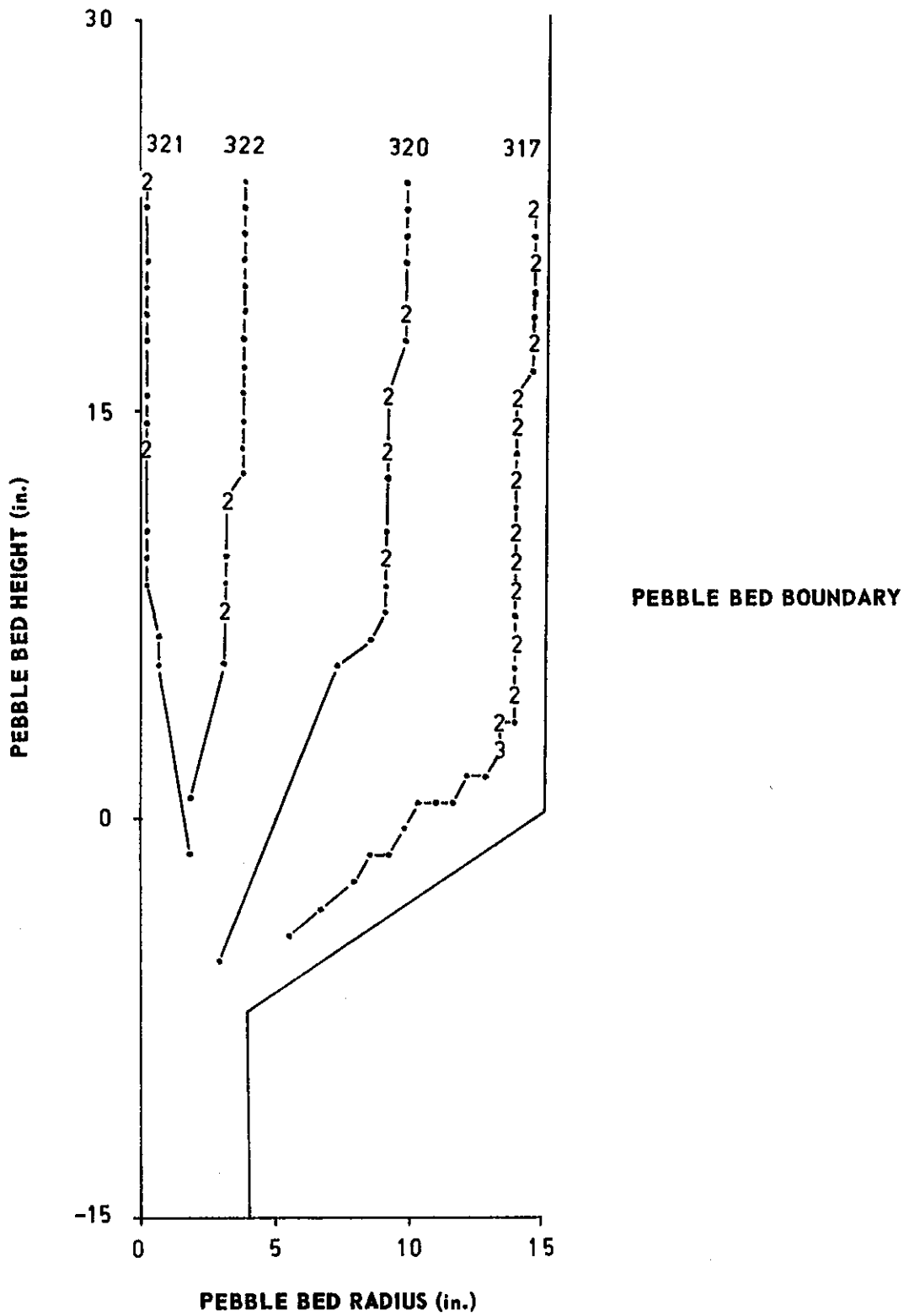

FIGURE 20. GROUP 38.

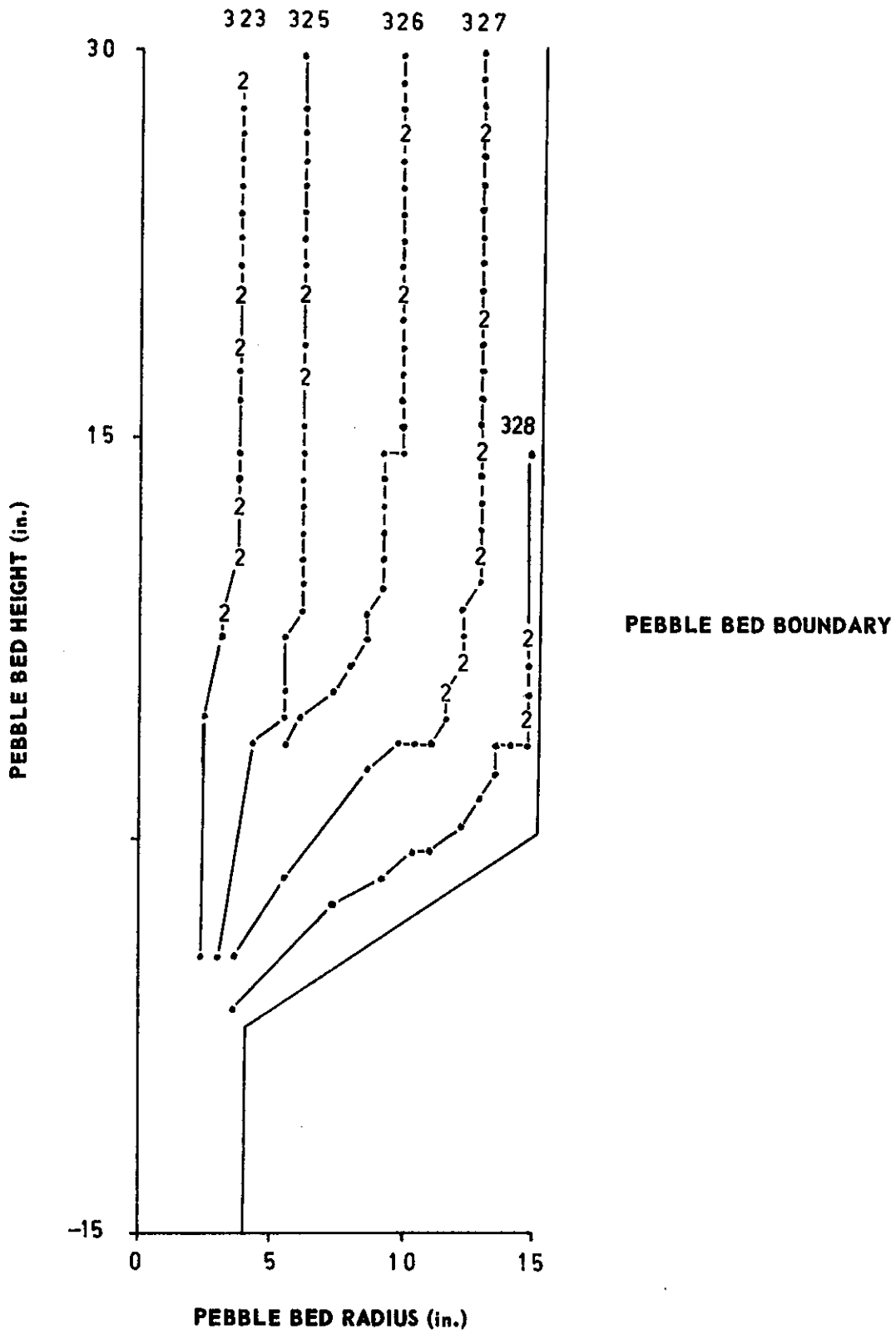

FIGURE 21. GROUP 39.

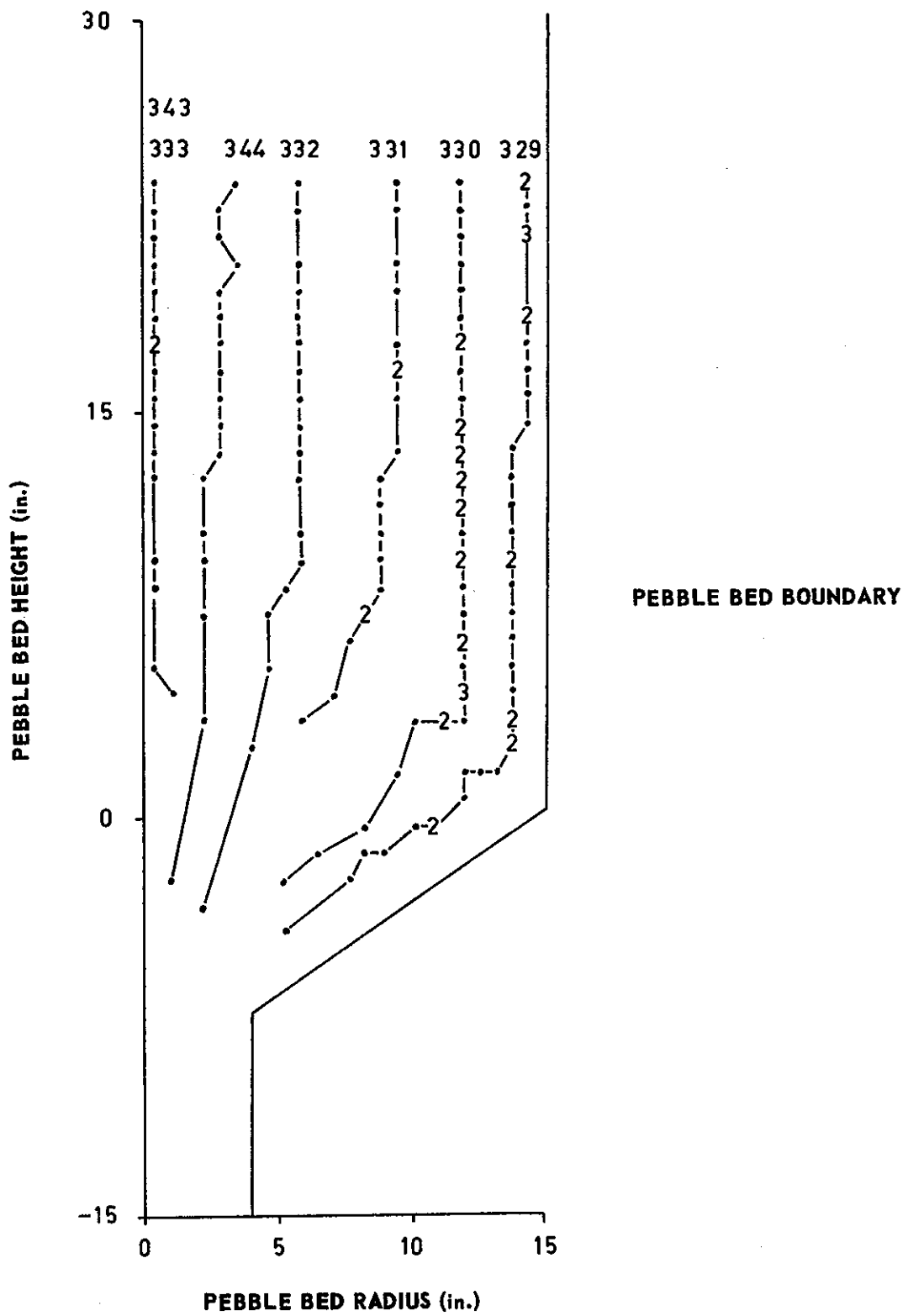

FIGURE 22. GROUP 40.

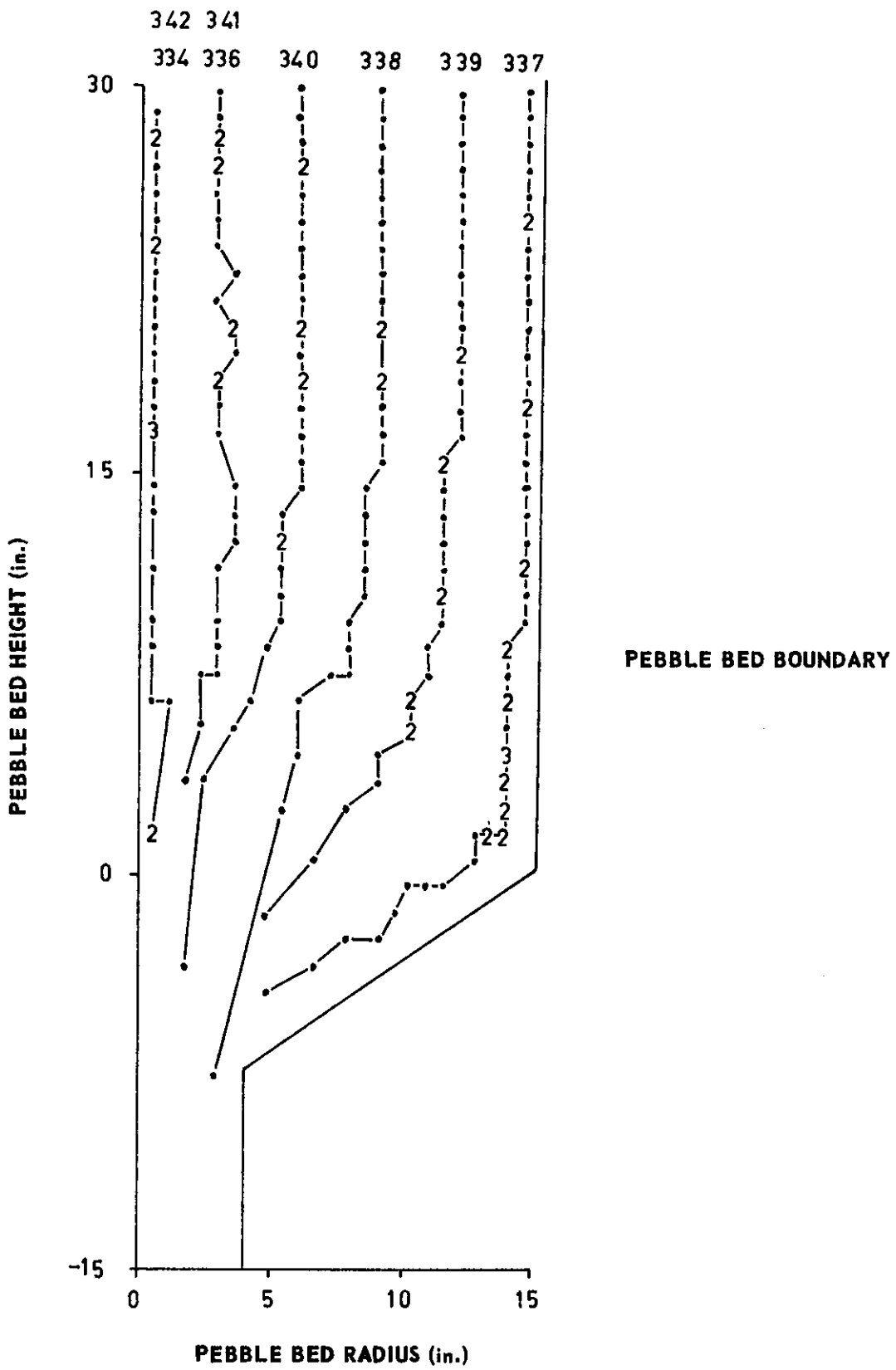

FIGURE 23. GROUP 41.

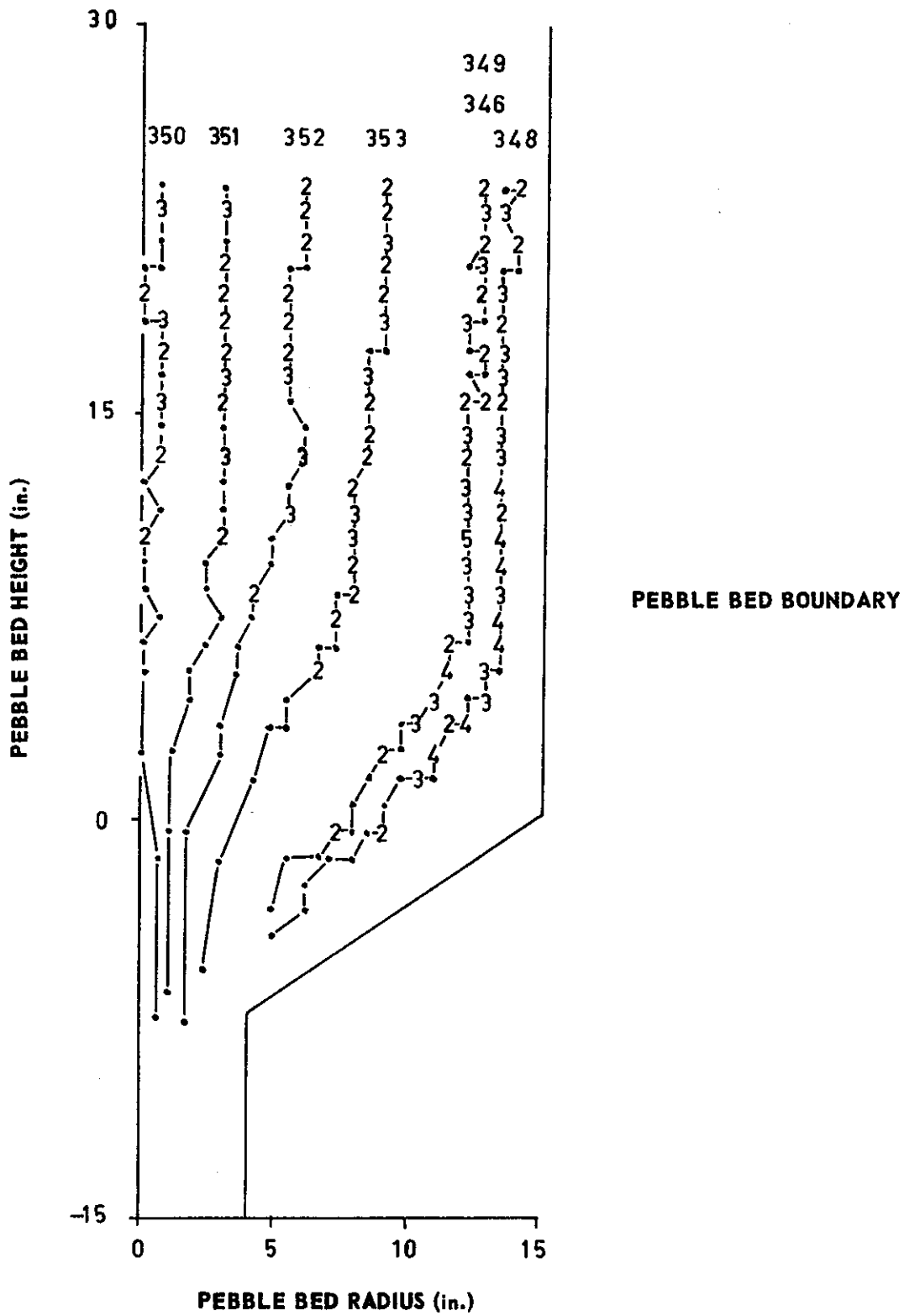

FIGURE 24. GROUP 42.

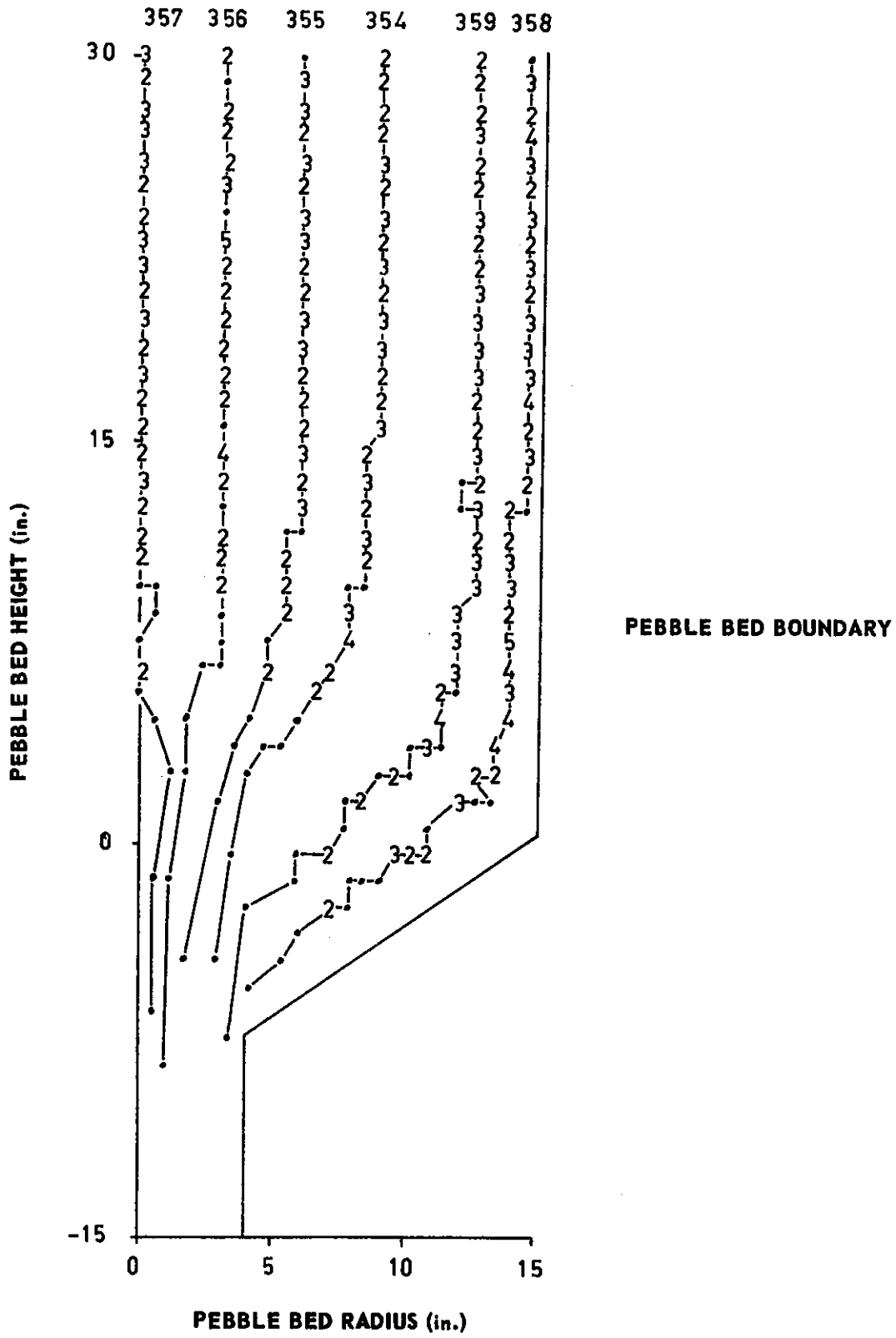

FIGURE 25. GROUP 43.

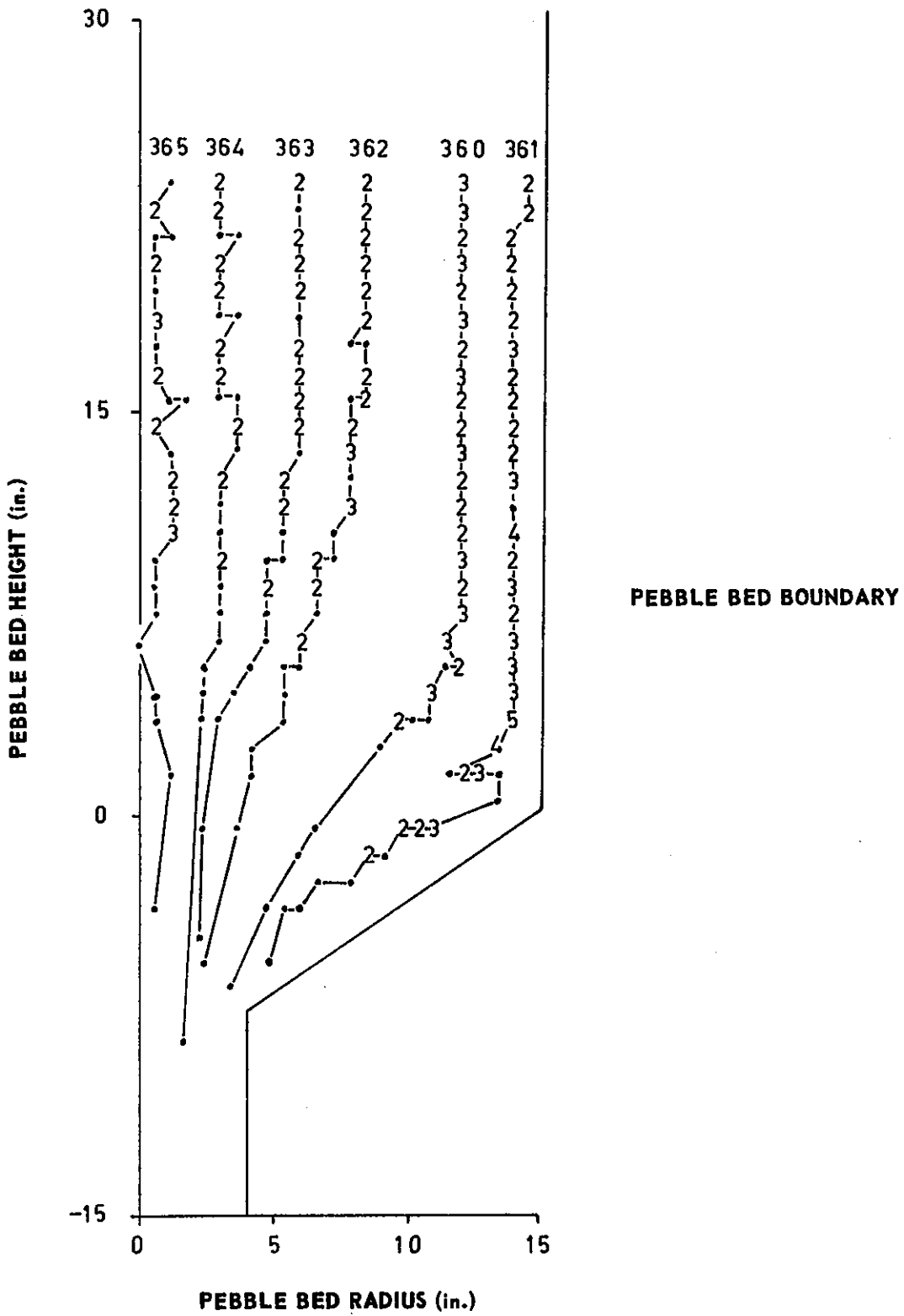

FIGURE 26. GROUP 44.

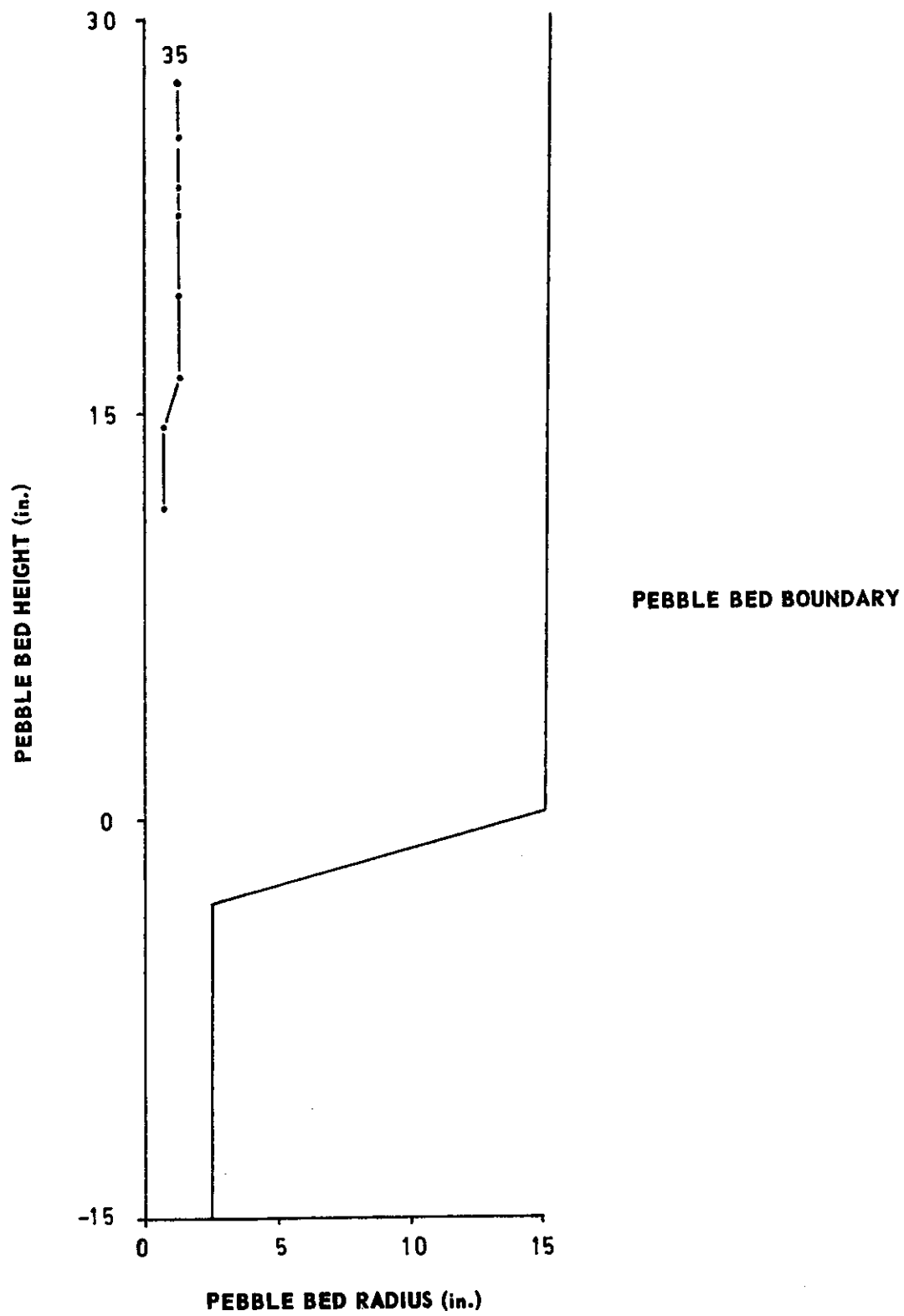

FIGURE 27. GROUP 9.

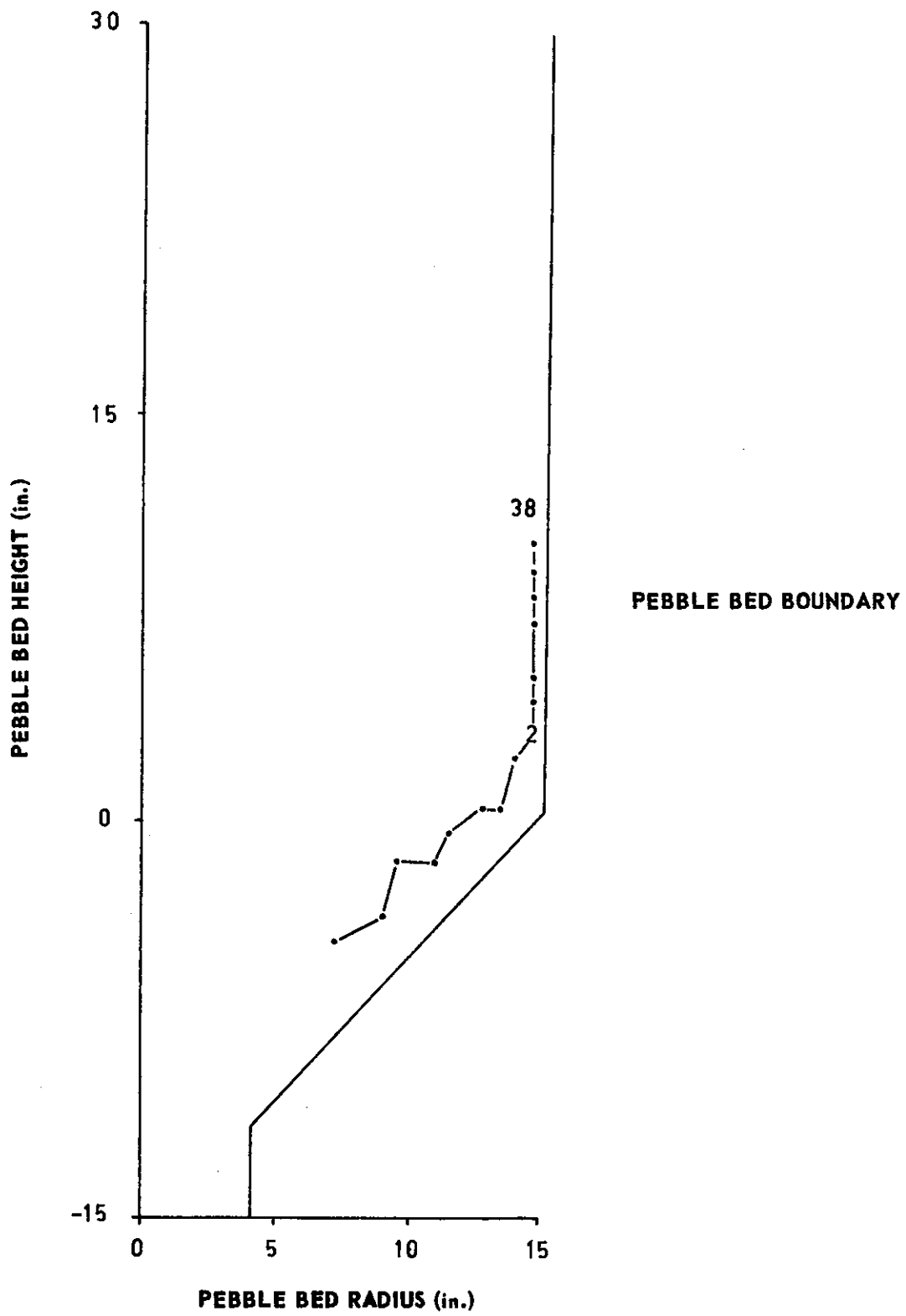

FIGURE 28. GROUP 10.

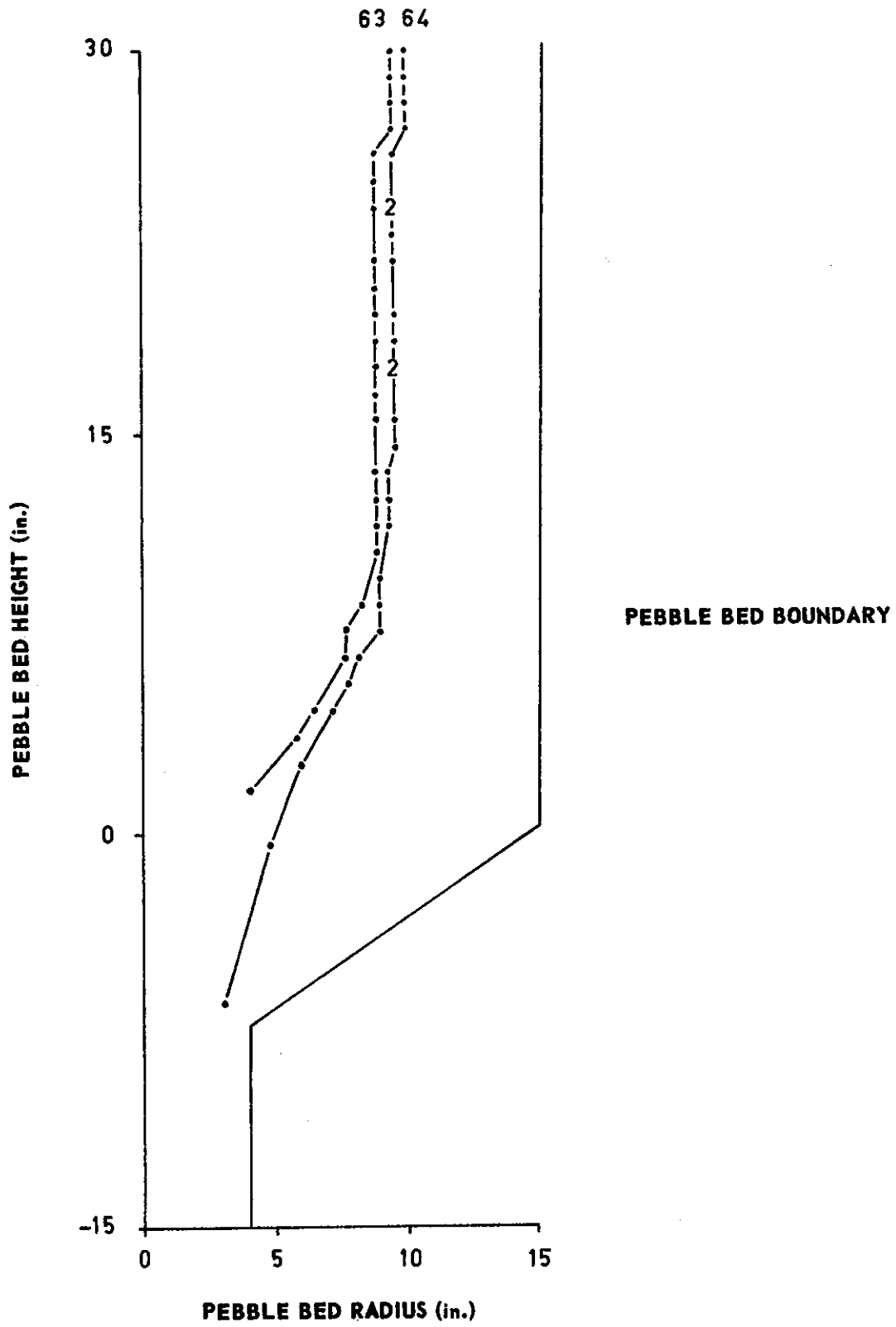

FIGURE 29. GROUP 16.

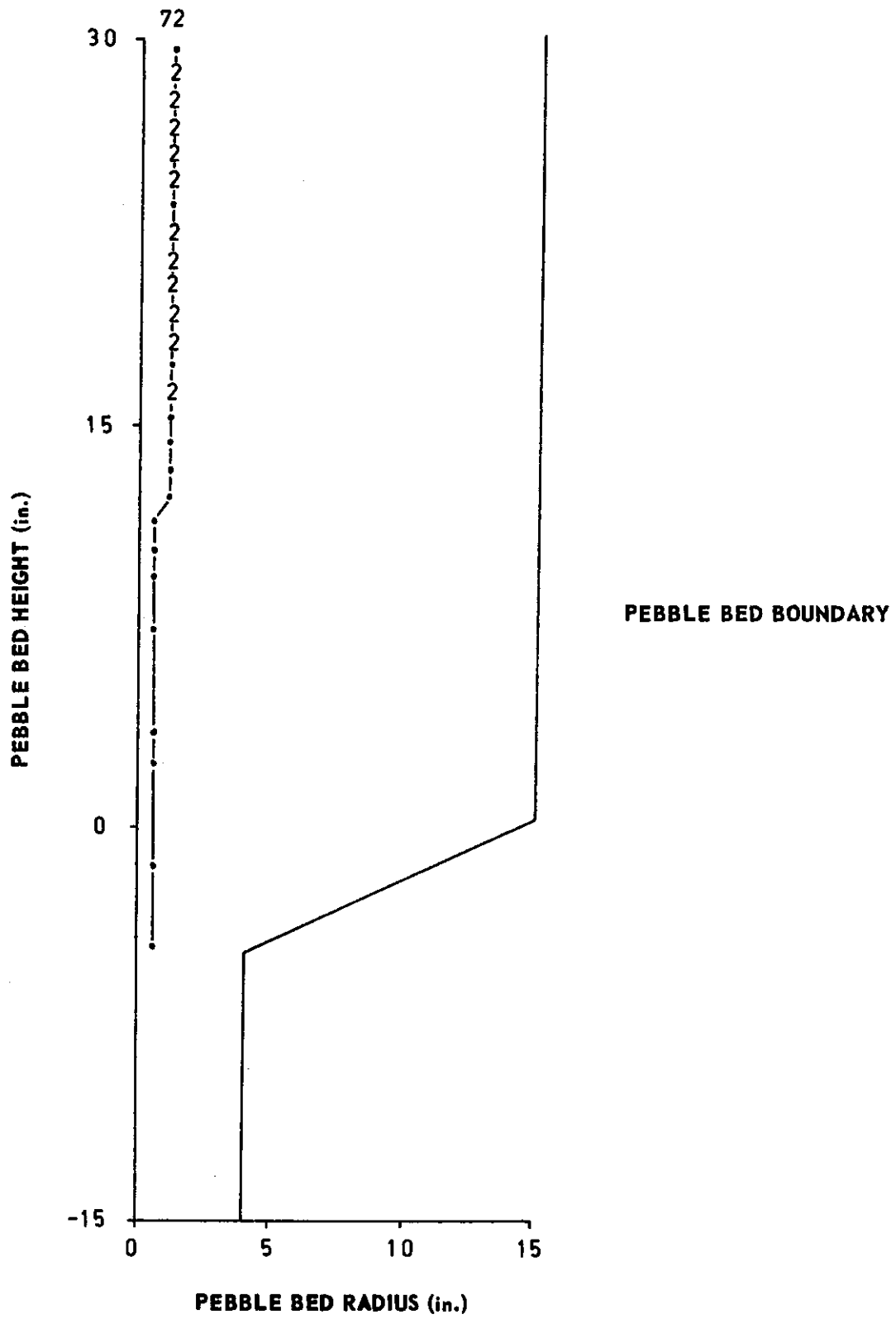

FIGURE 30. GROUP 19.

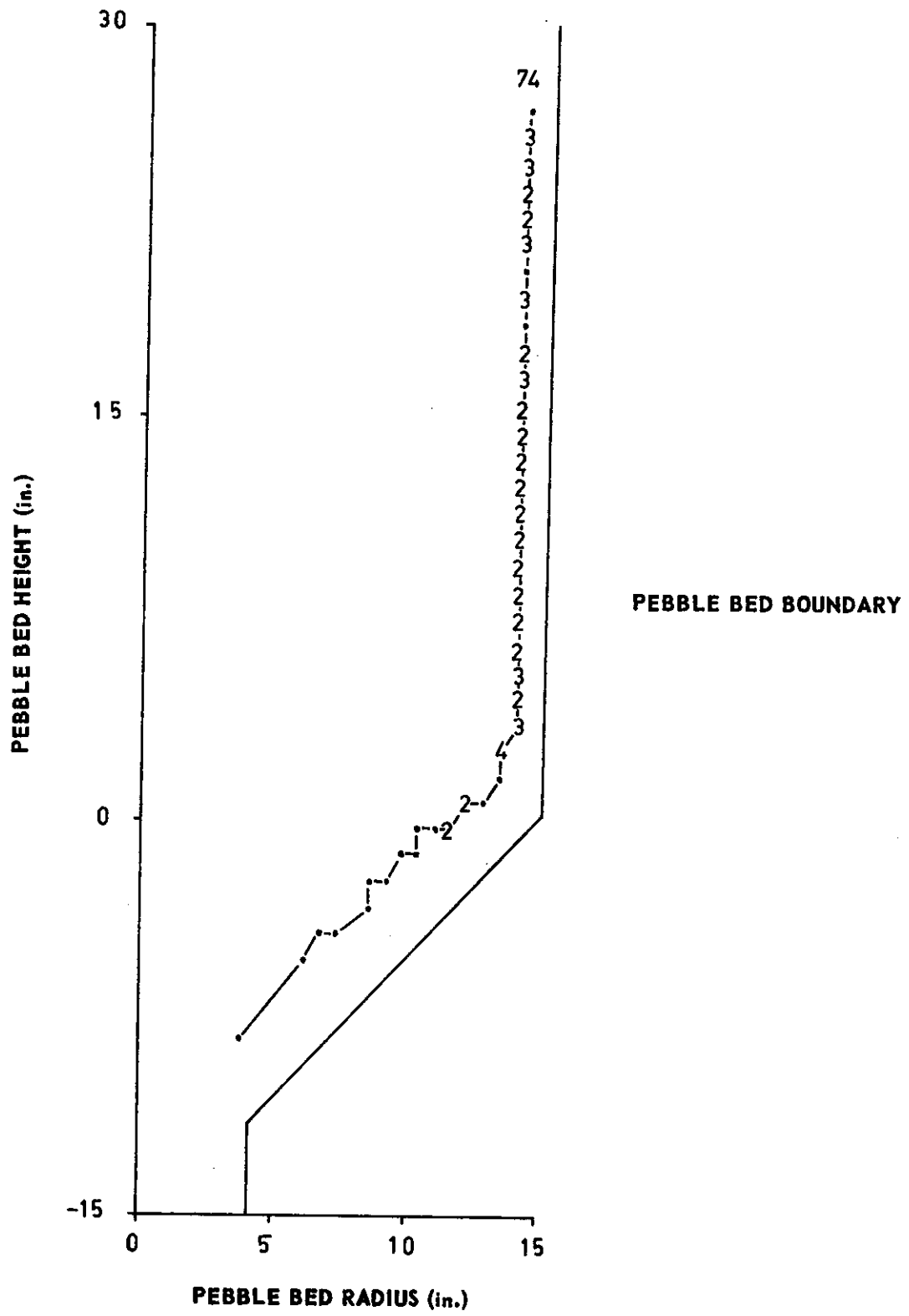

FIGURE 32. GROUP 21.

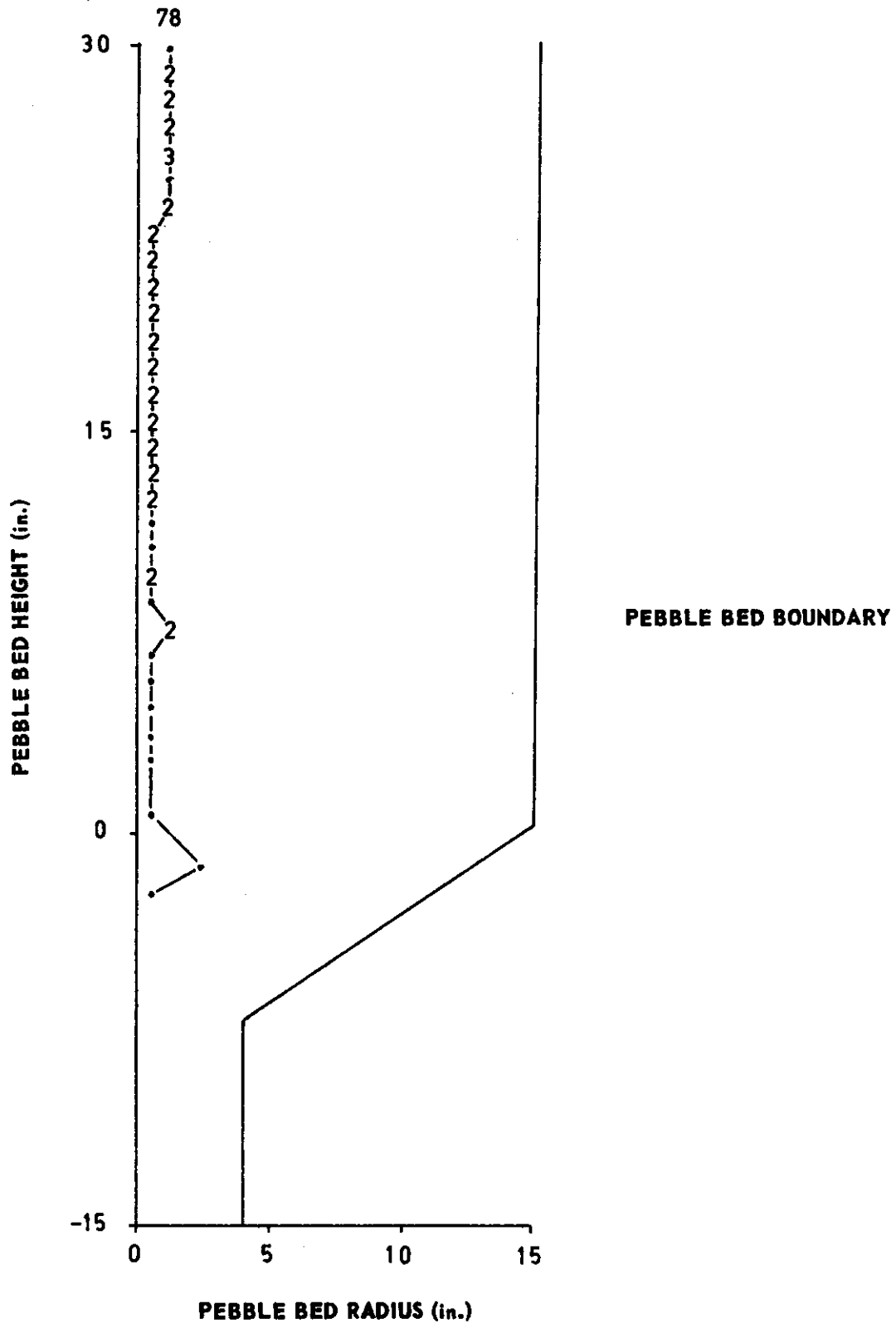

FIGURE 33. GROUP 23.

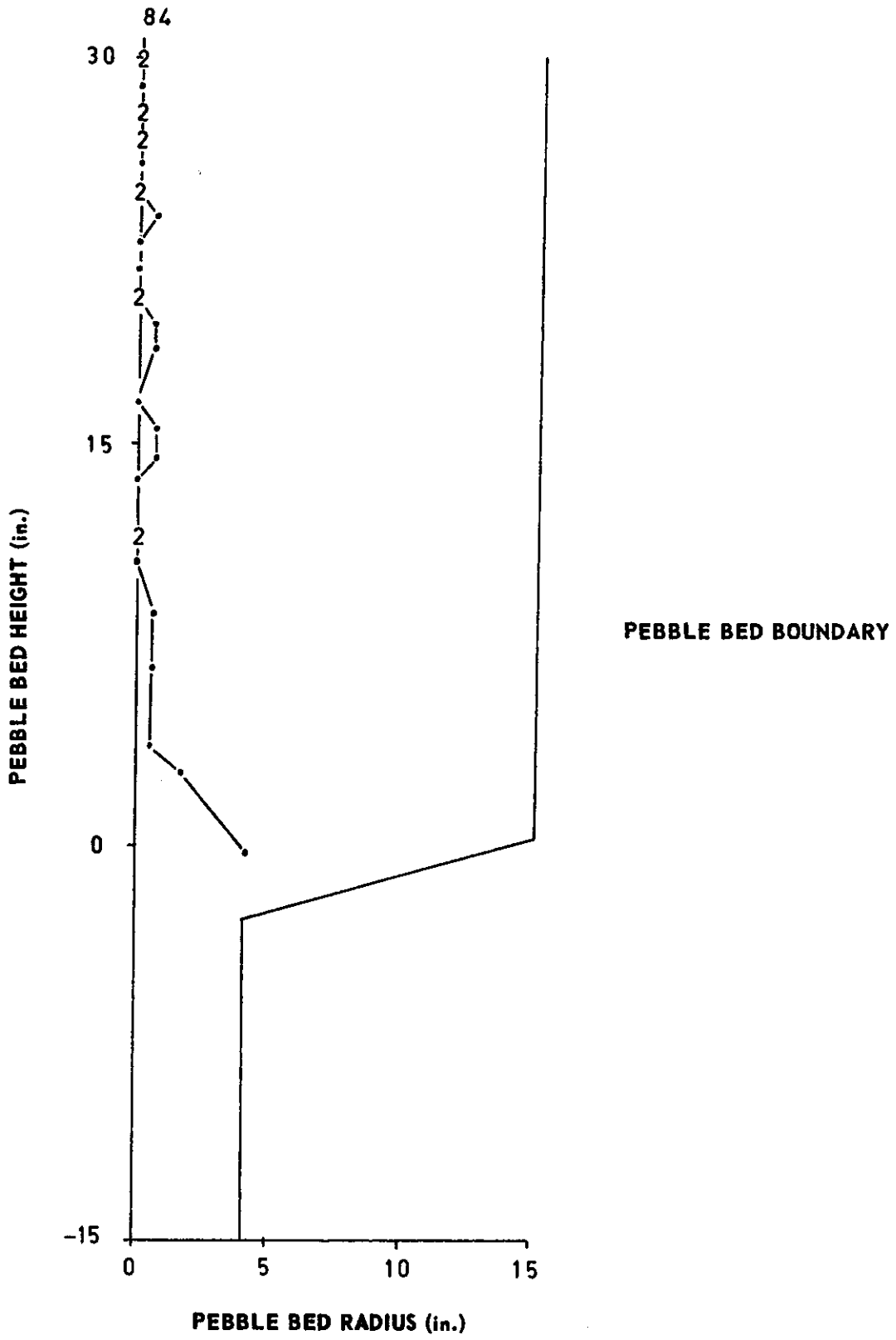

FIGURE 34. GROUP 26.

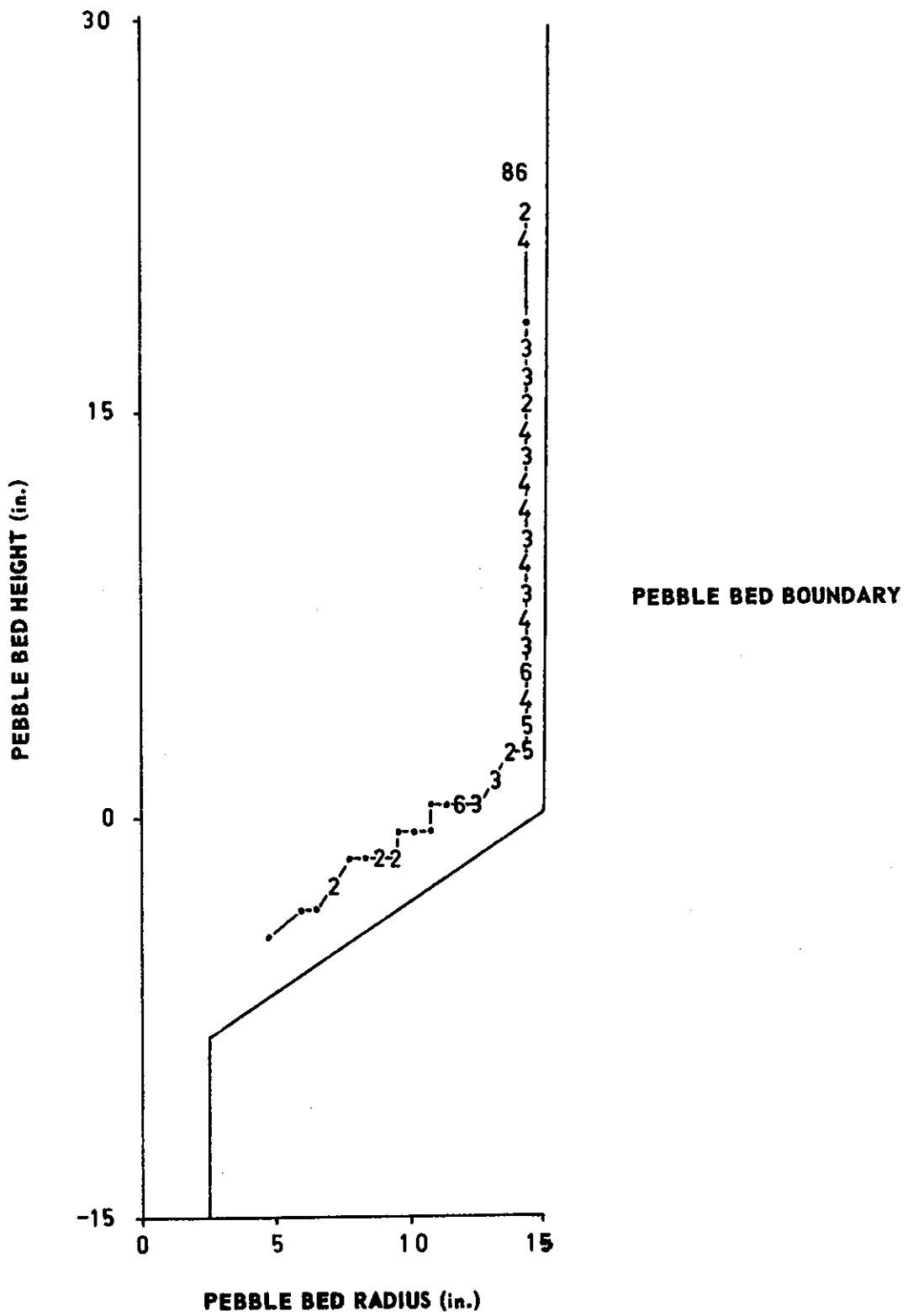

FIGURE 35. GROUP 27.

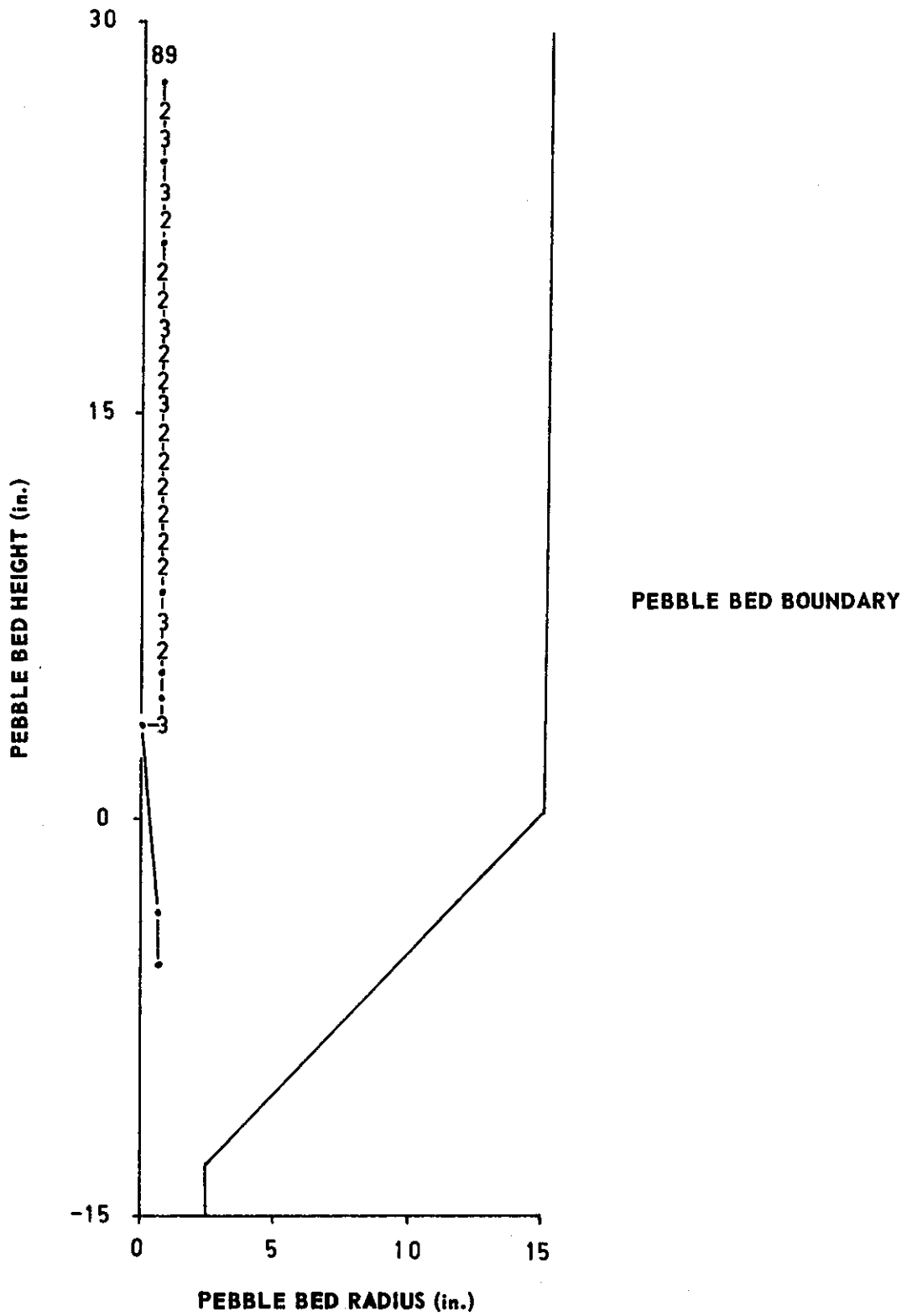

FIGURE 36. GROUP 29.

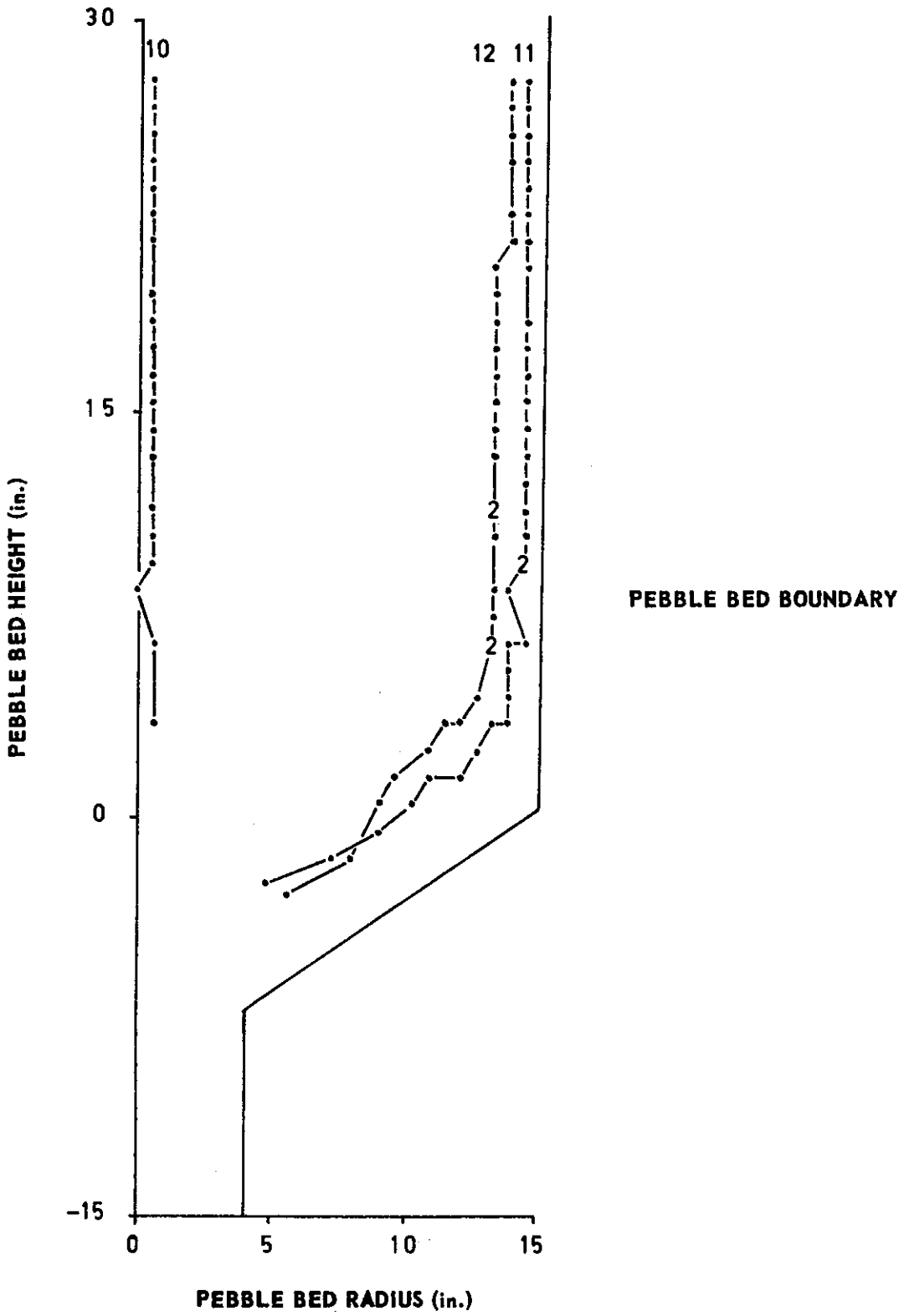

FIGURE 38. GROUP 1.

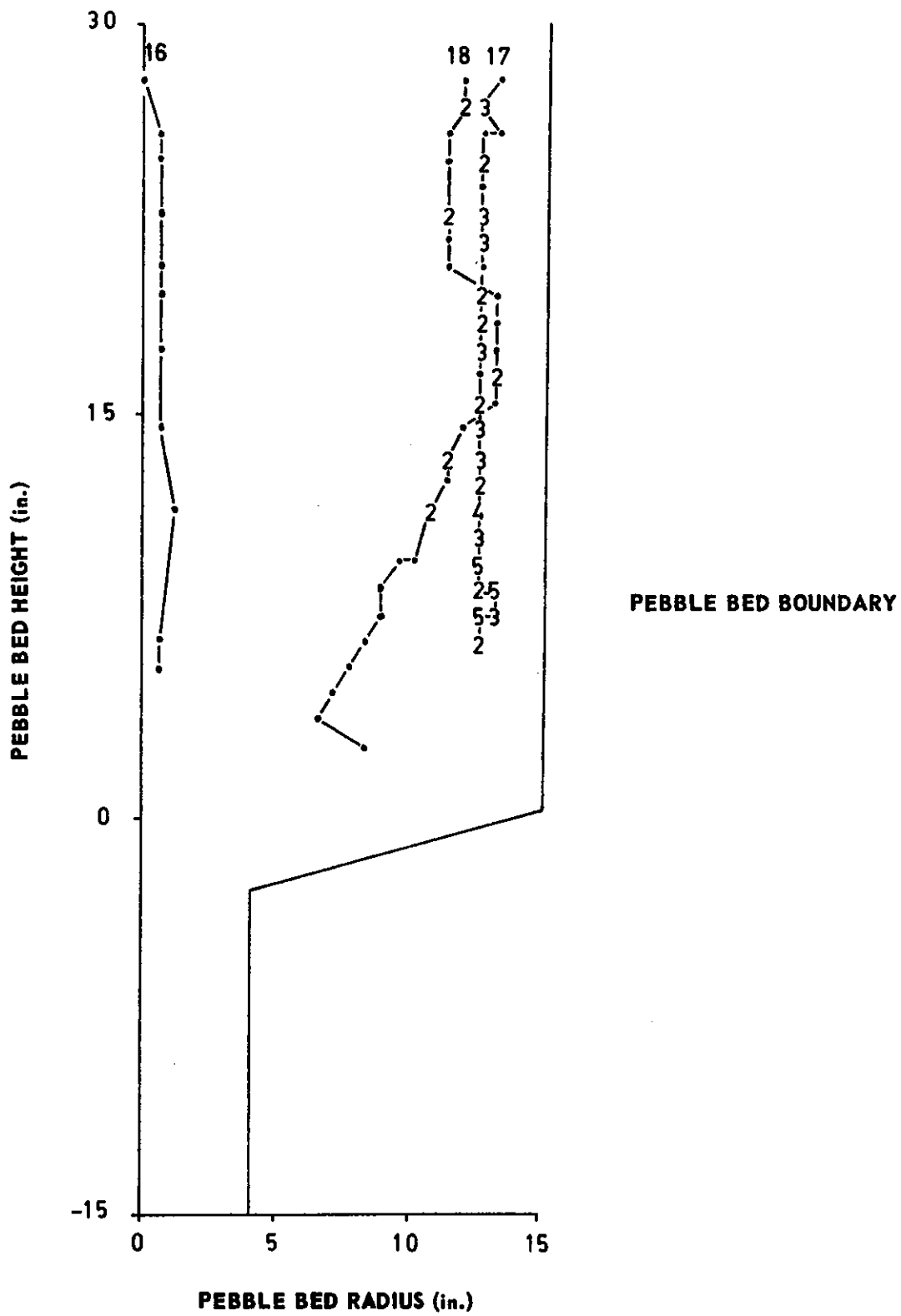

FIGURE 39. GROUP 2.

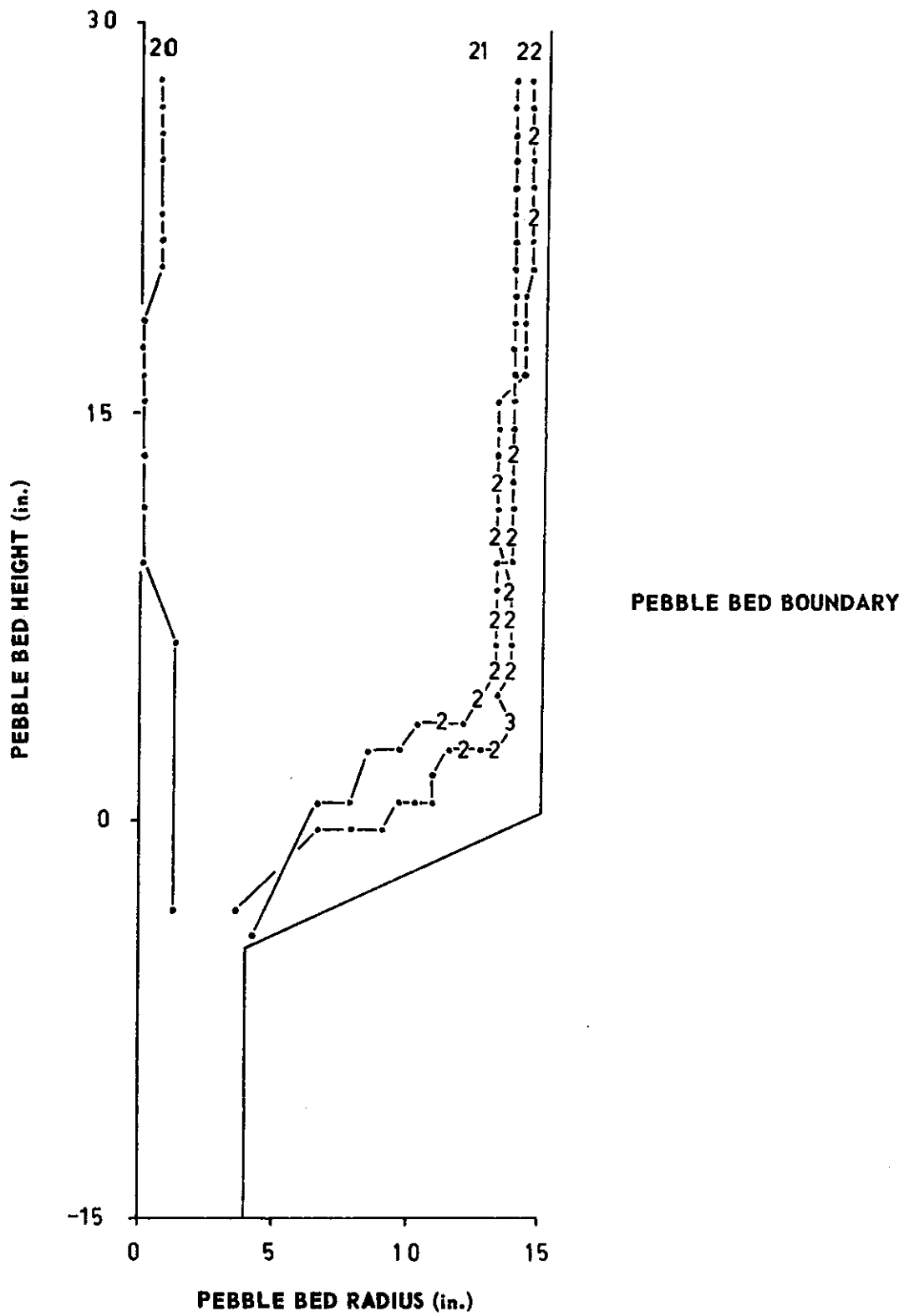

FIGURE 40. GROUP 3.

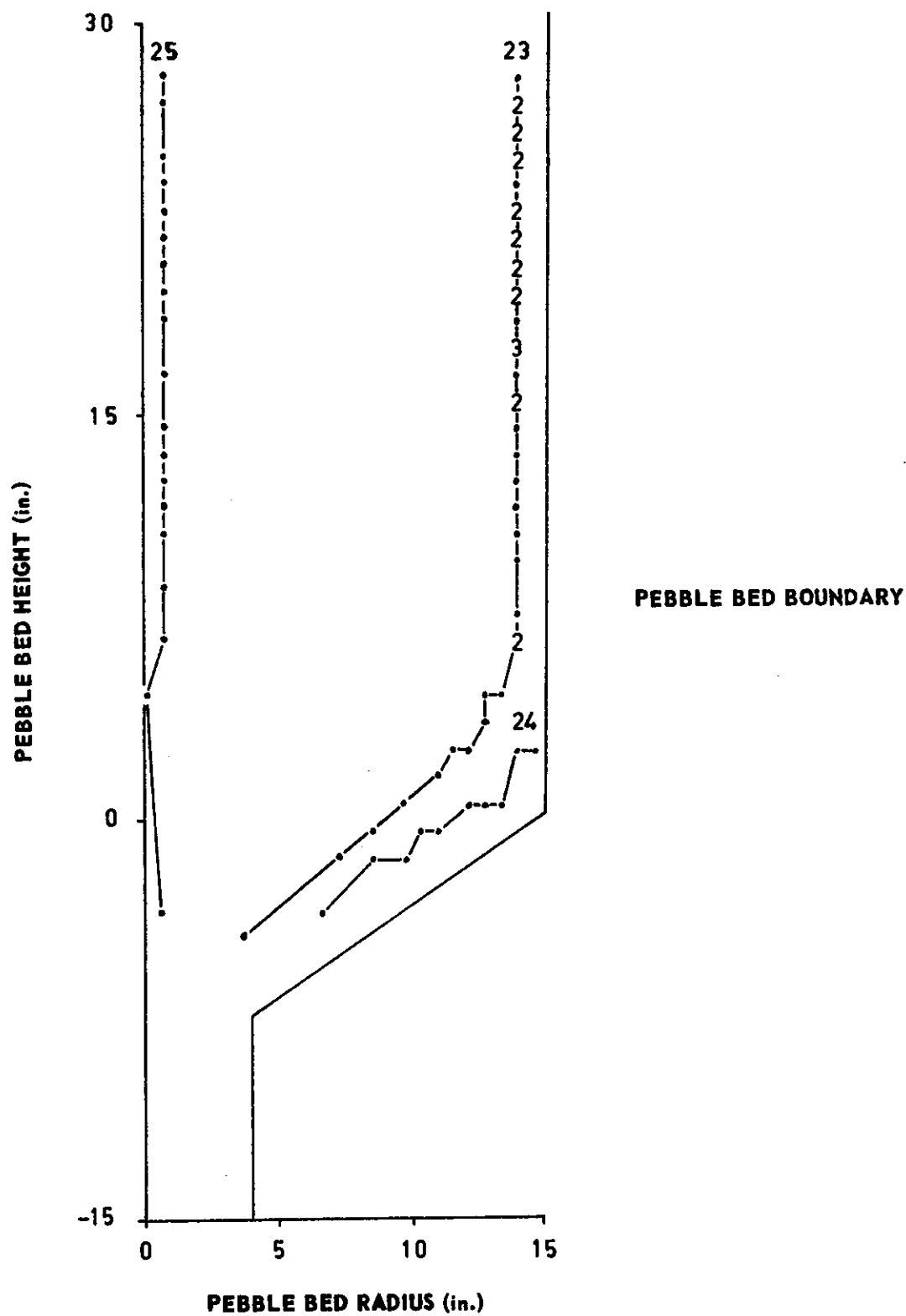

FIGURE 41. GROUP 4.

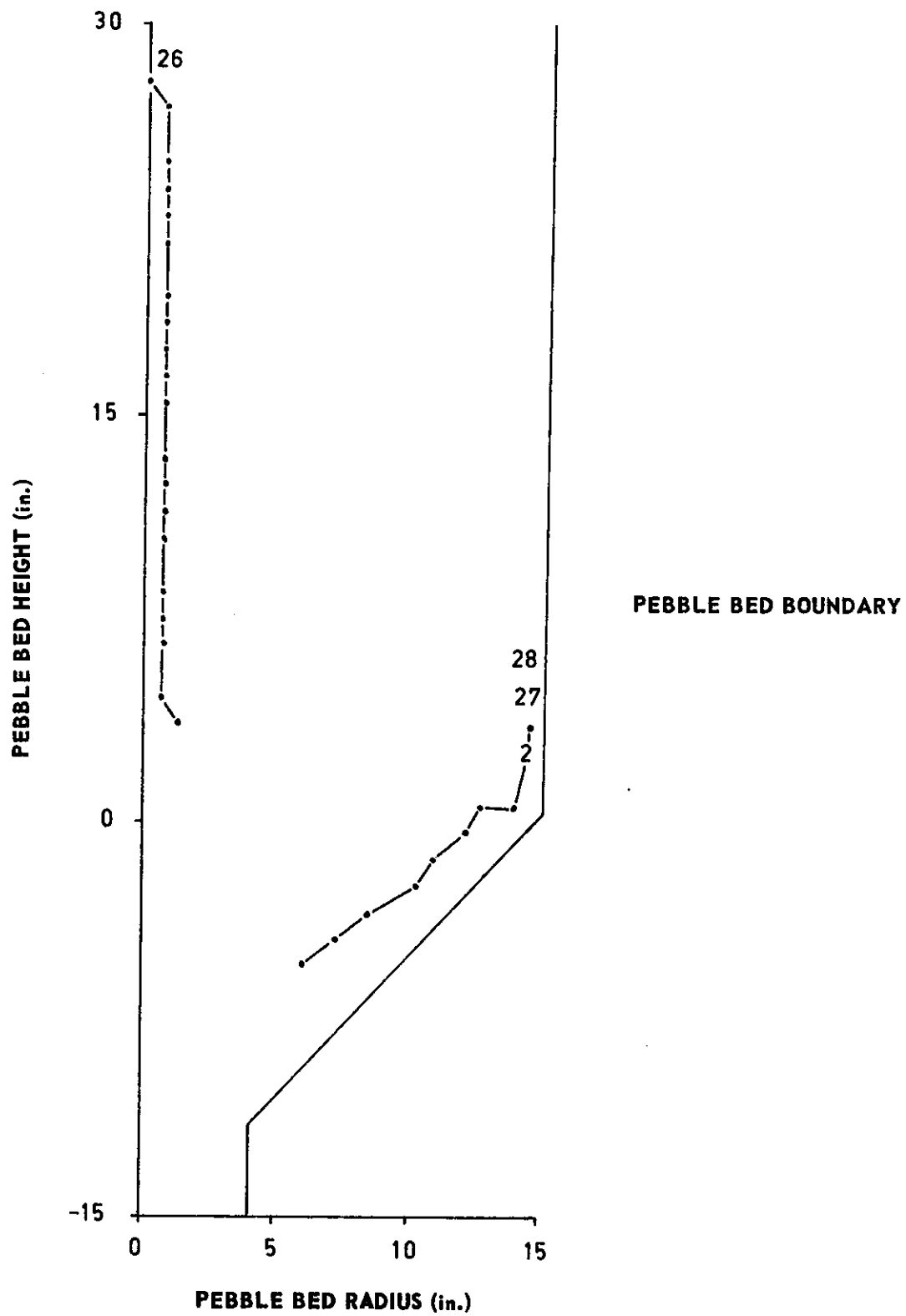

FIGURE 42. GROUP 5.

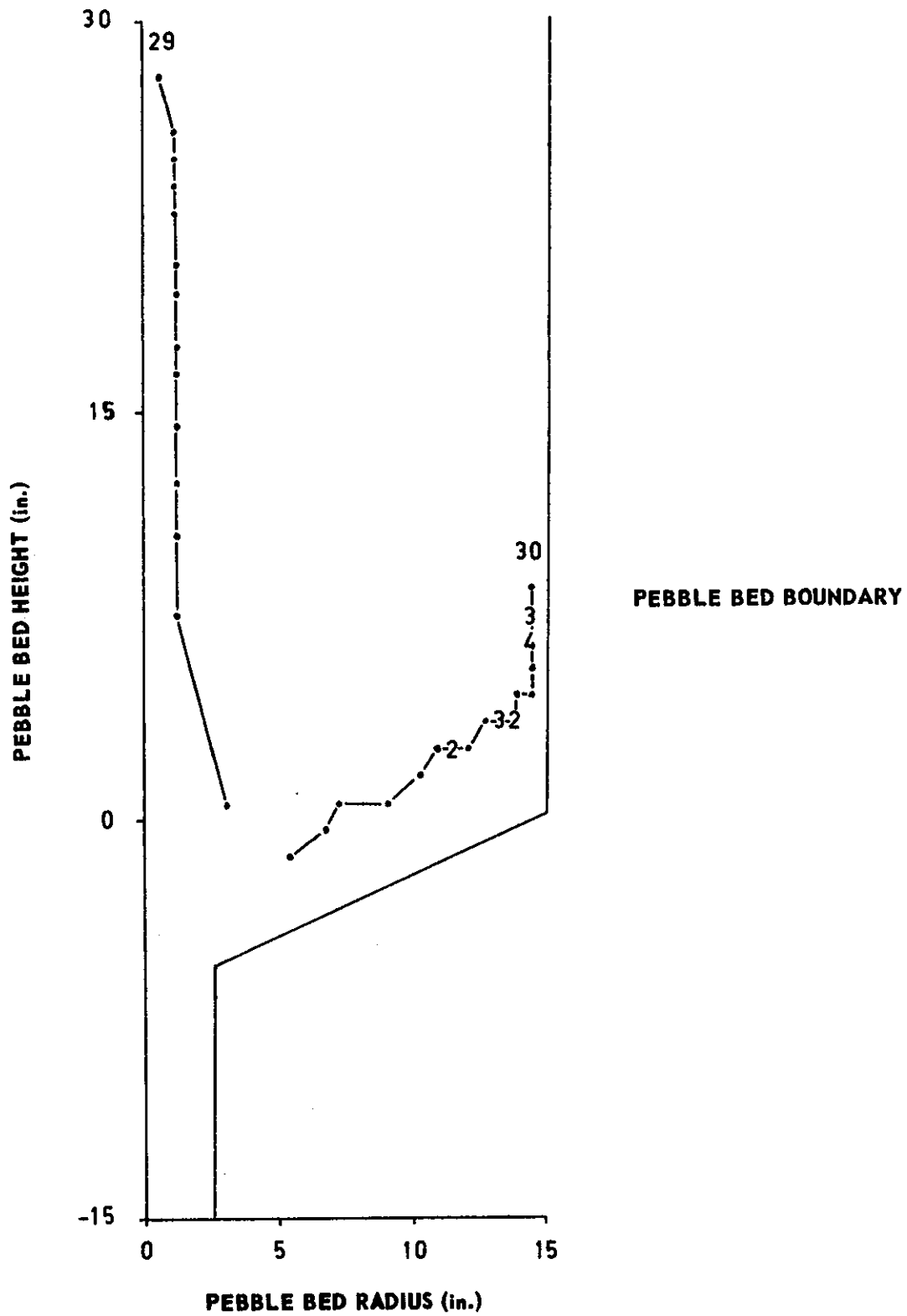

FIGURE 43. GROUP 6.

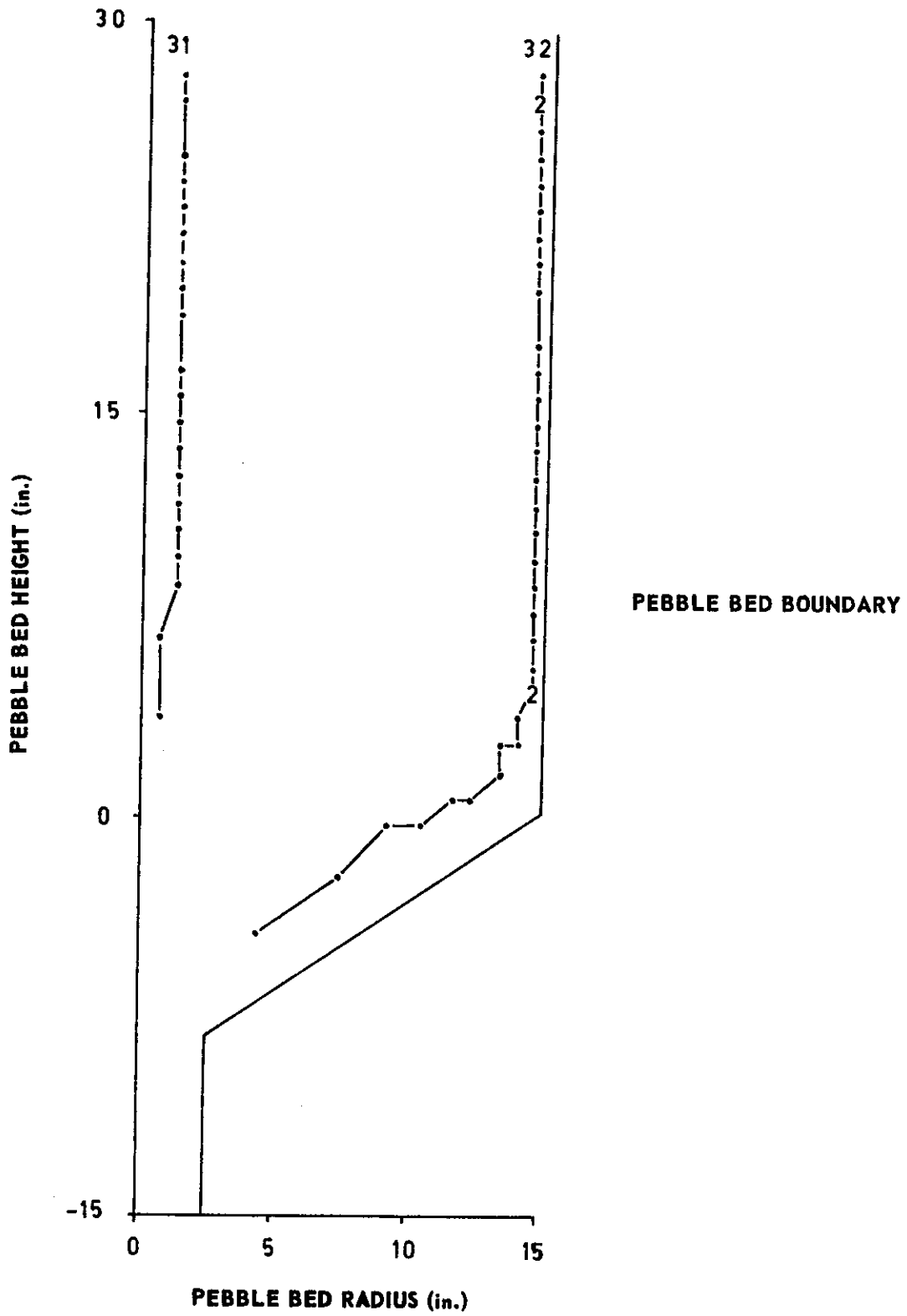

FIGURE 44. GROUP 7.

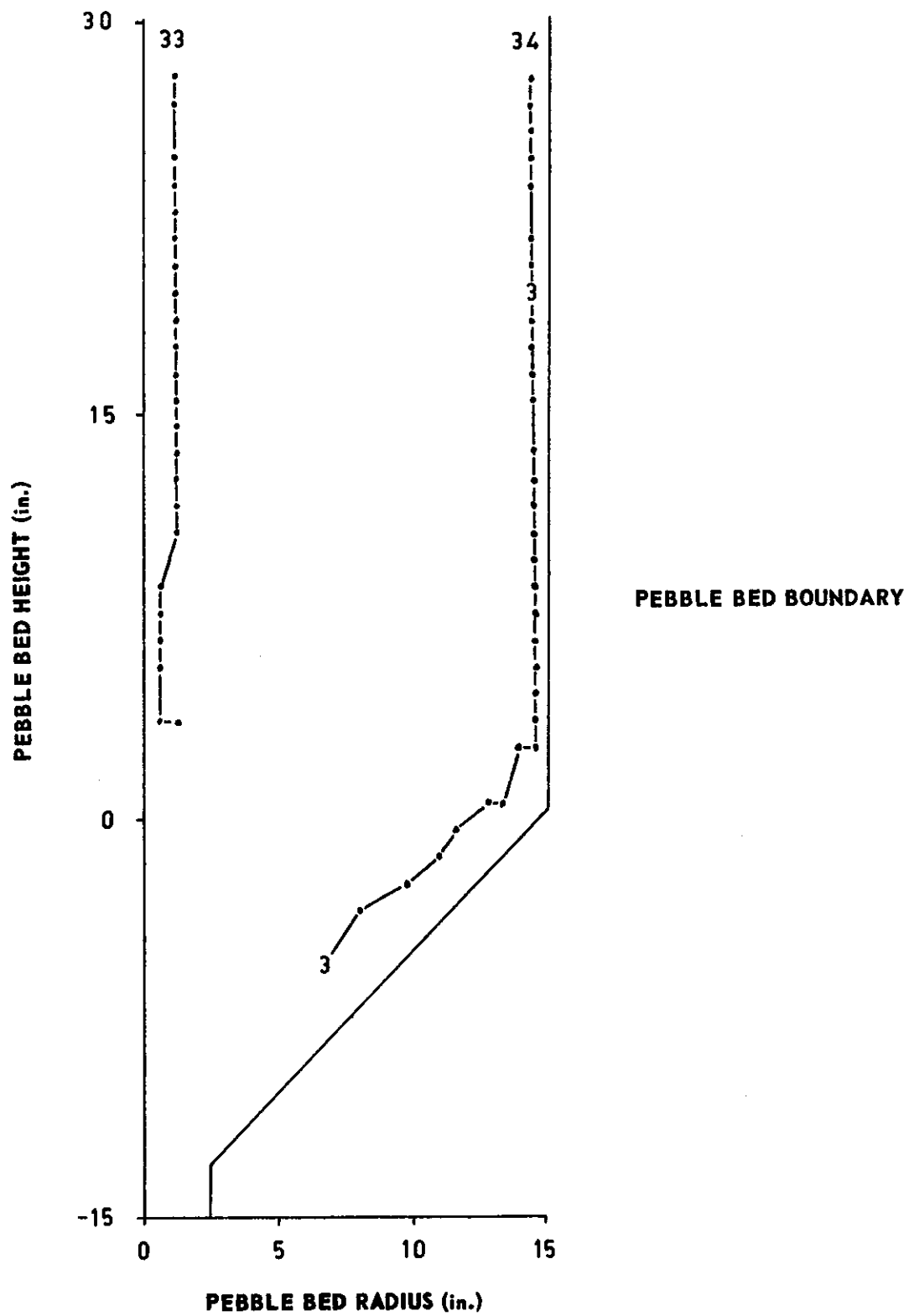

FIGURE 45. GROUP 8.

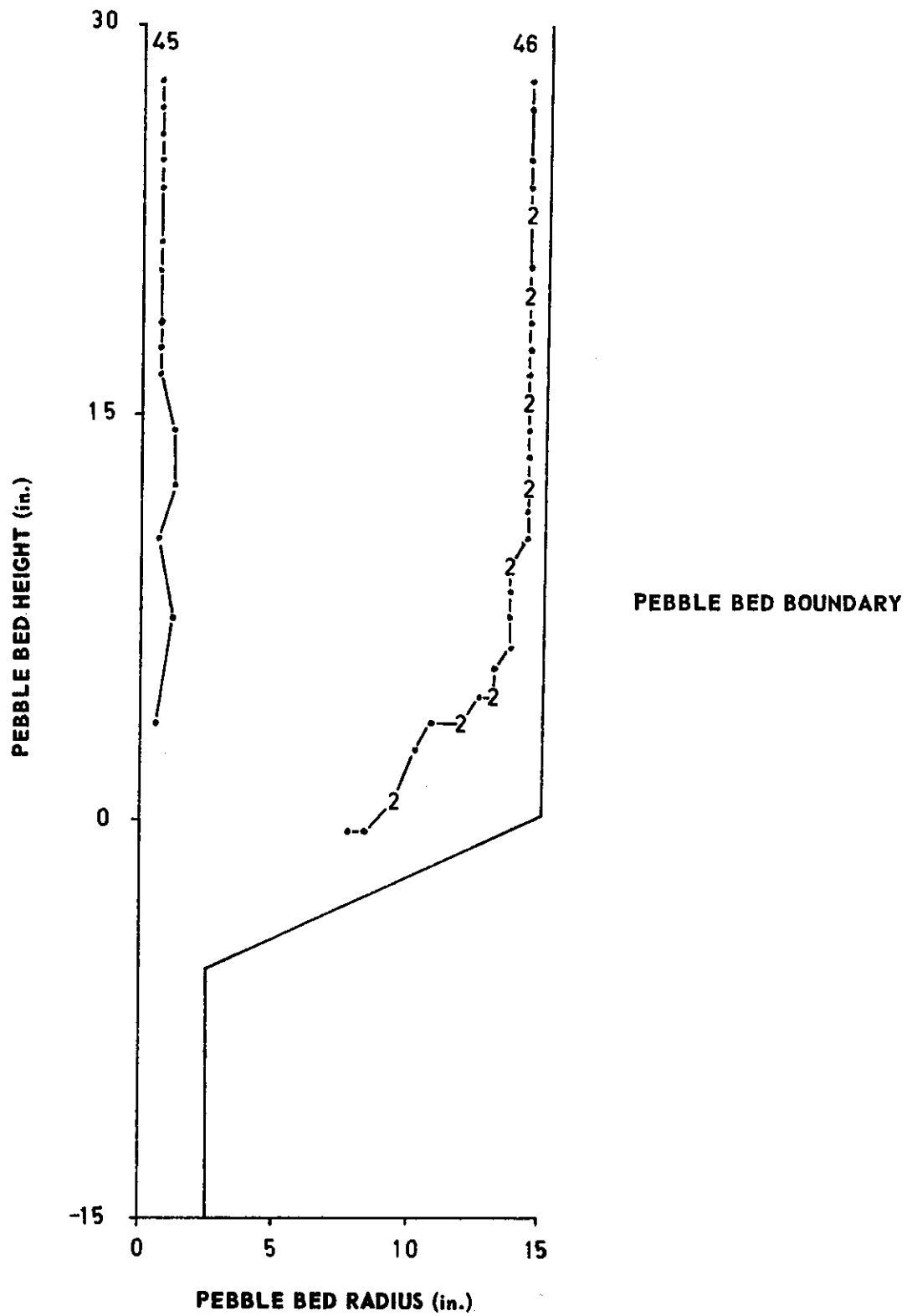

FIGURE 48. GROUP 13.

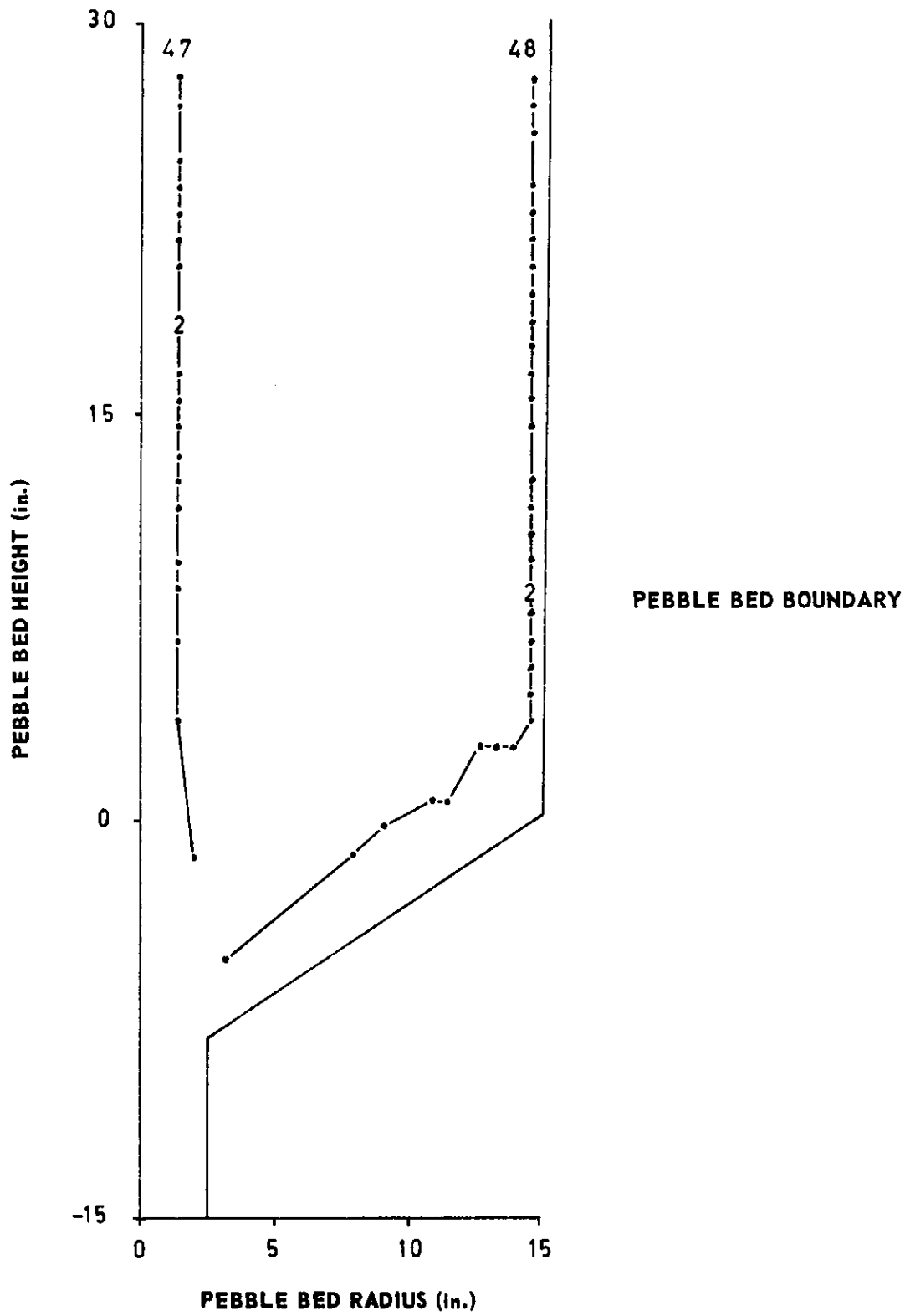

FIGURE 49. GROUP 14.

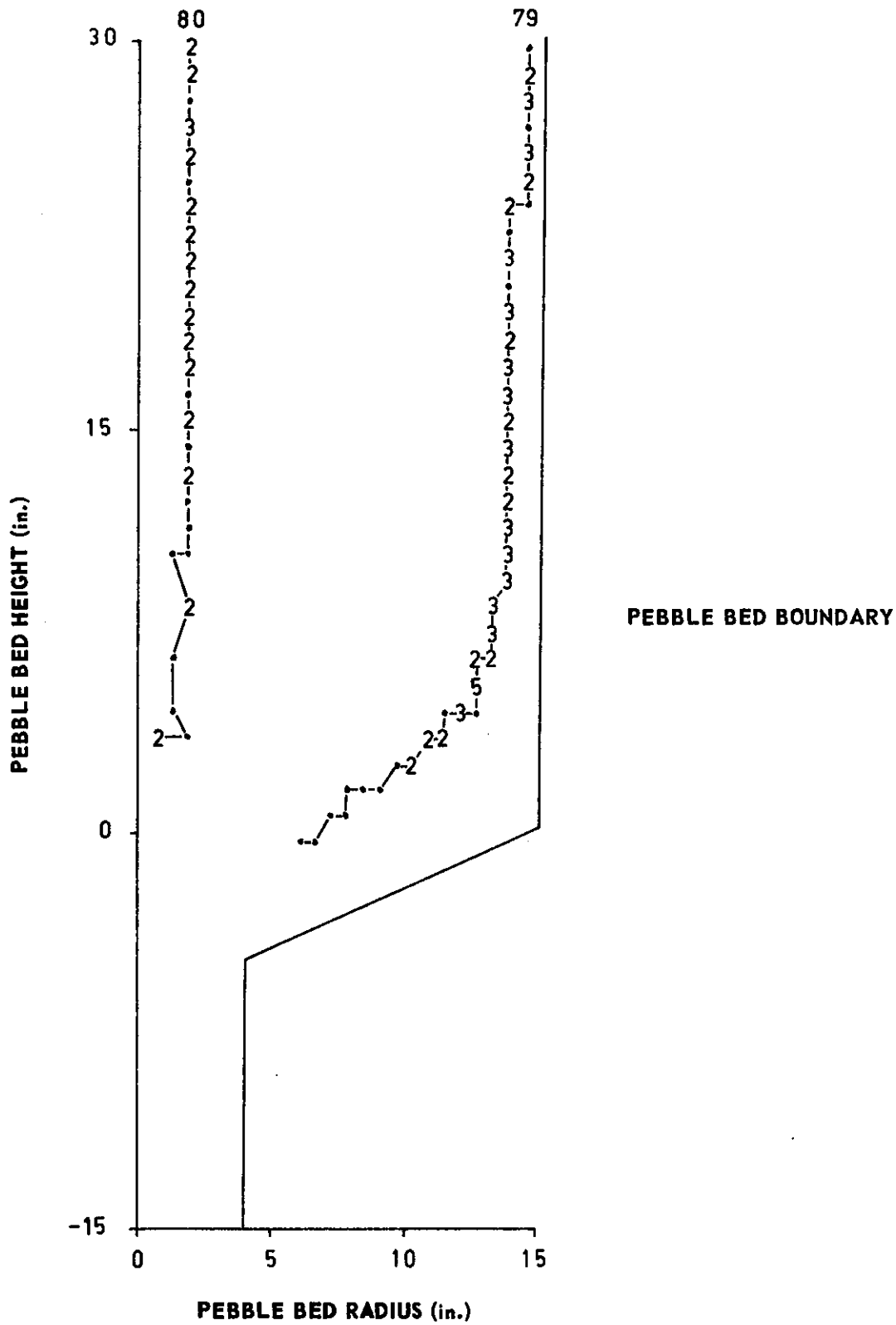

FIGURE 50. GROUP 24.

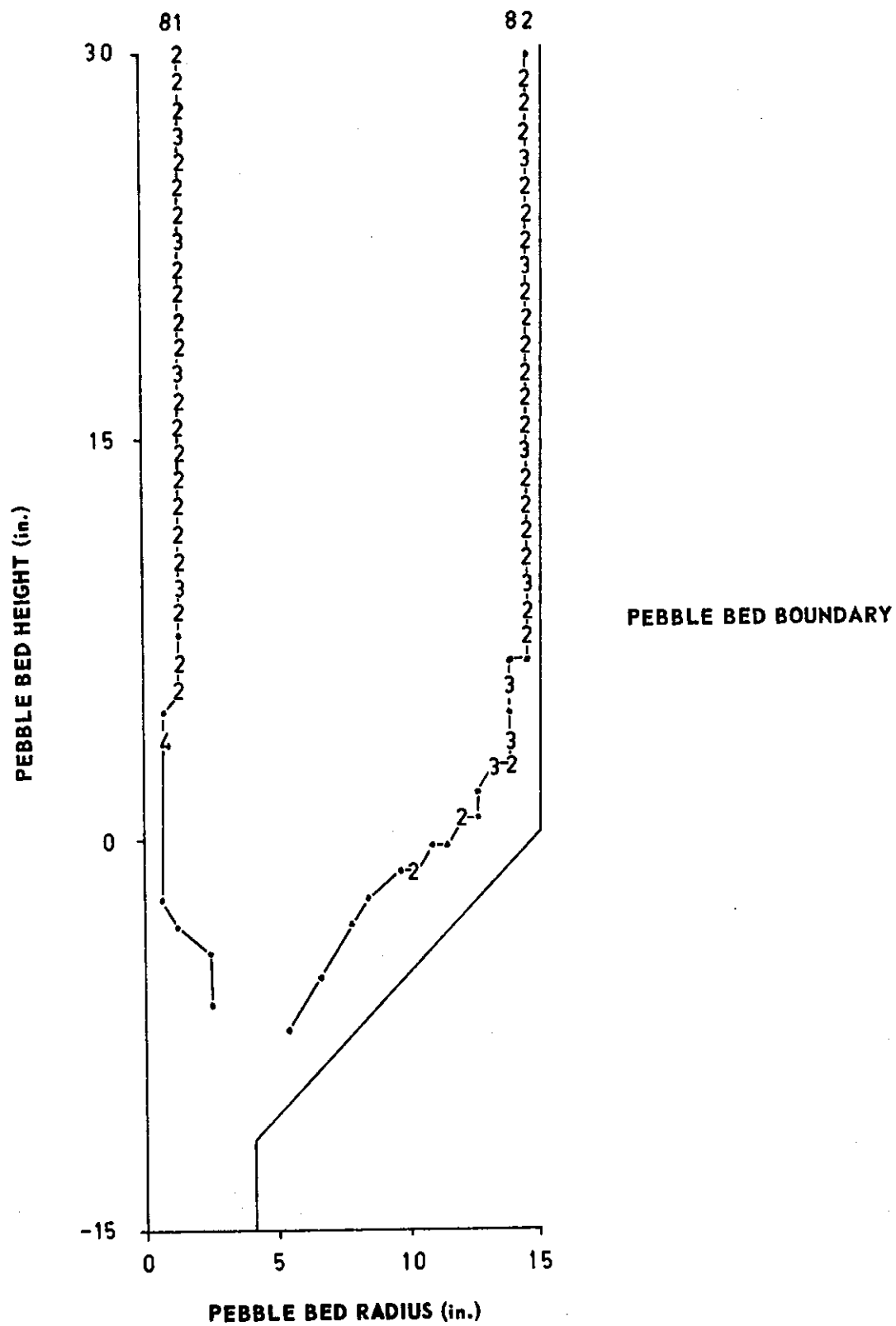

FIGURE 51. GROUP 25.

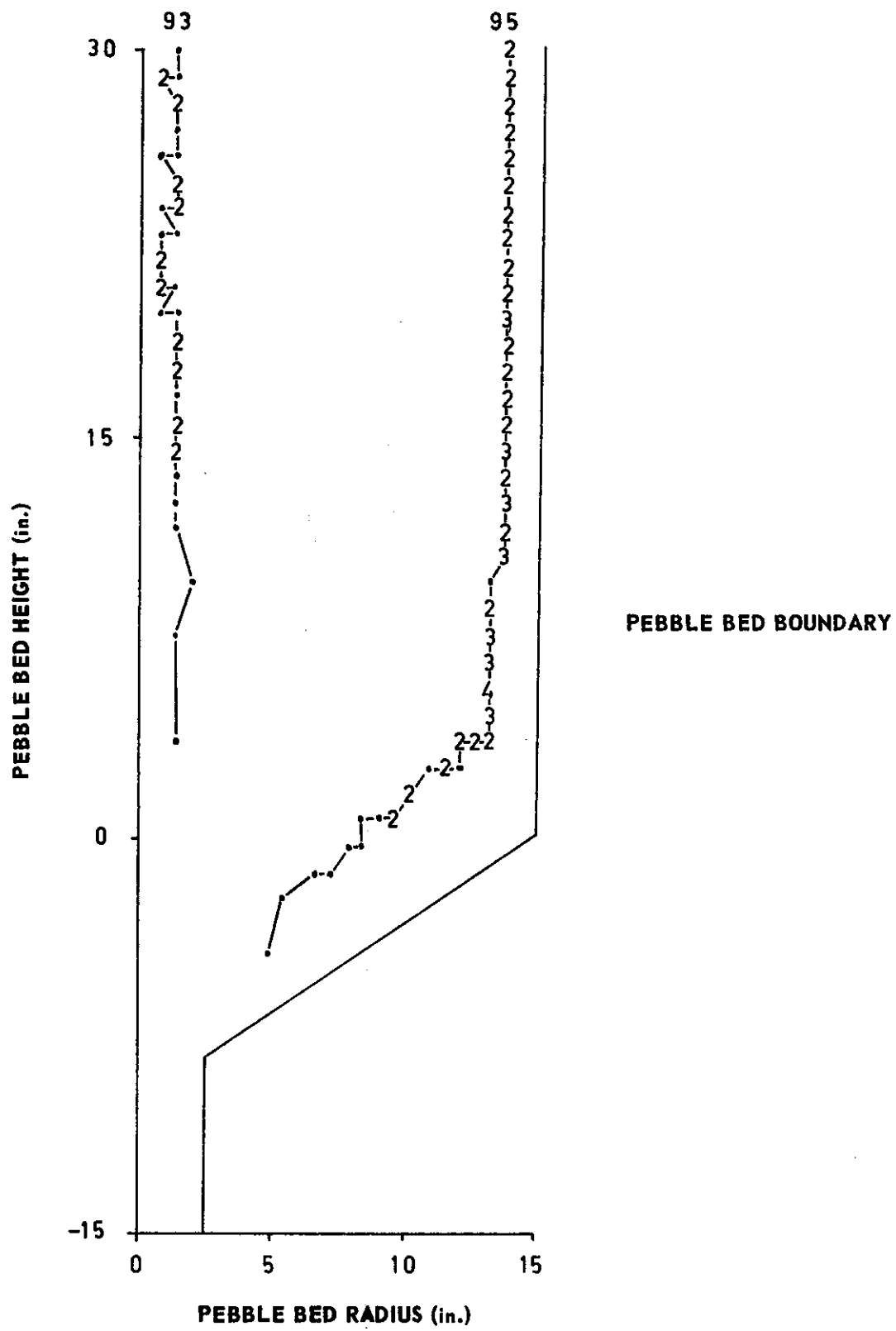

FIGURE 54. GROUP 32.

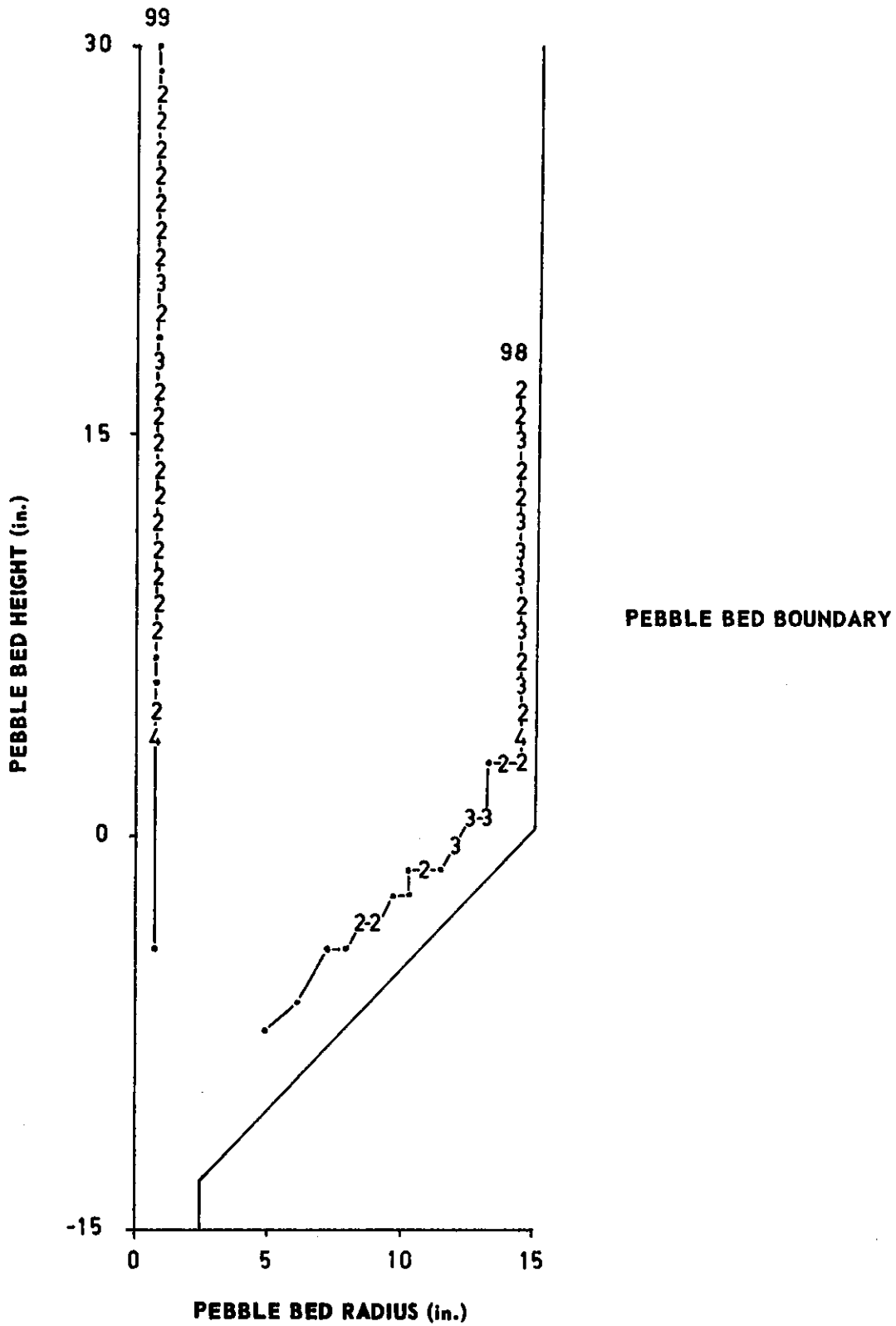
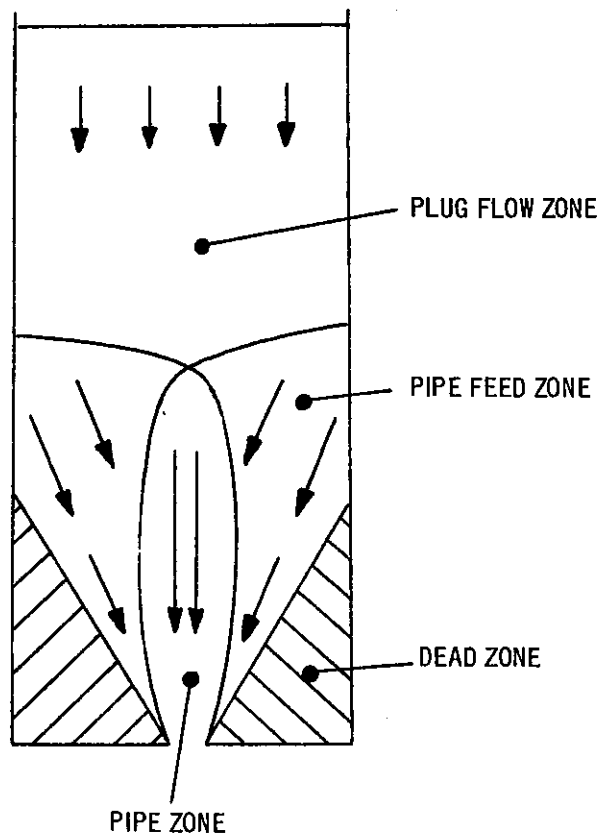

FIGURE 55. GROUP 33.

(ARROWS INDICATE RELATIVE VELOCITIES)



**FIGURE 56. DIAGRAM OF FLOW ZONES AND FLOW PATTERNS
(After Deutsch 1967a)**

FIGURES 57-64

FLOW ZONES

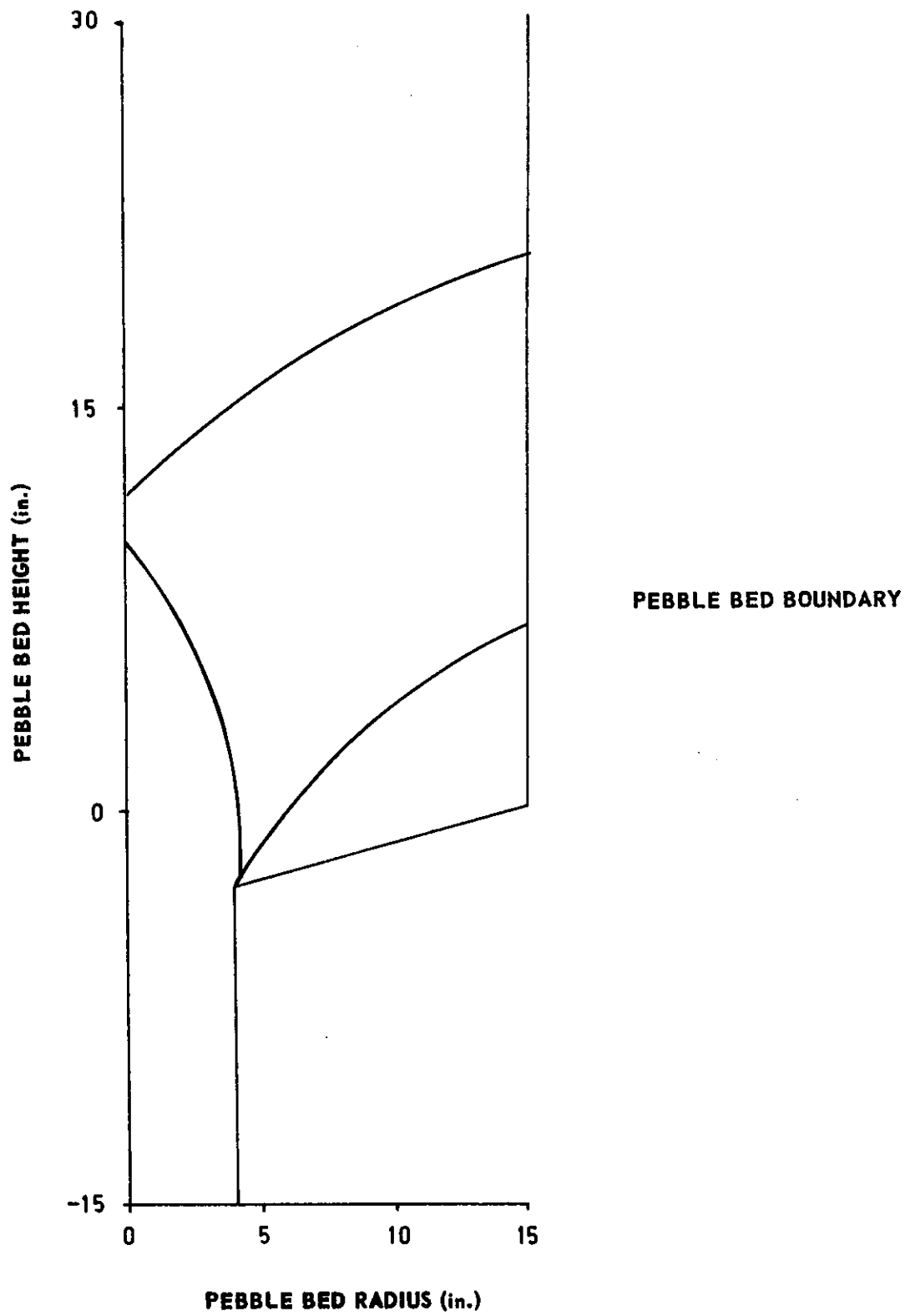

FIGURE 57. BASE ANGLE 15°, EXTRACTOR DIA. 8 in.

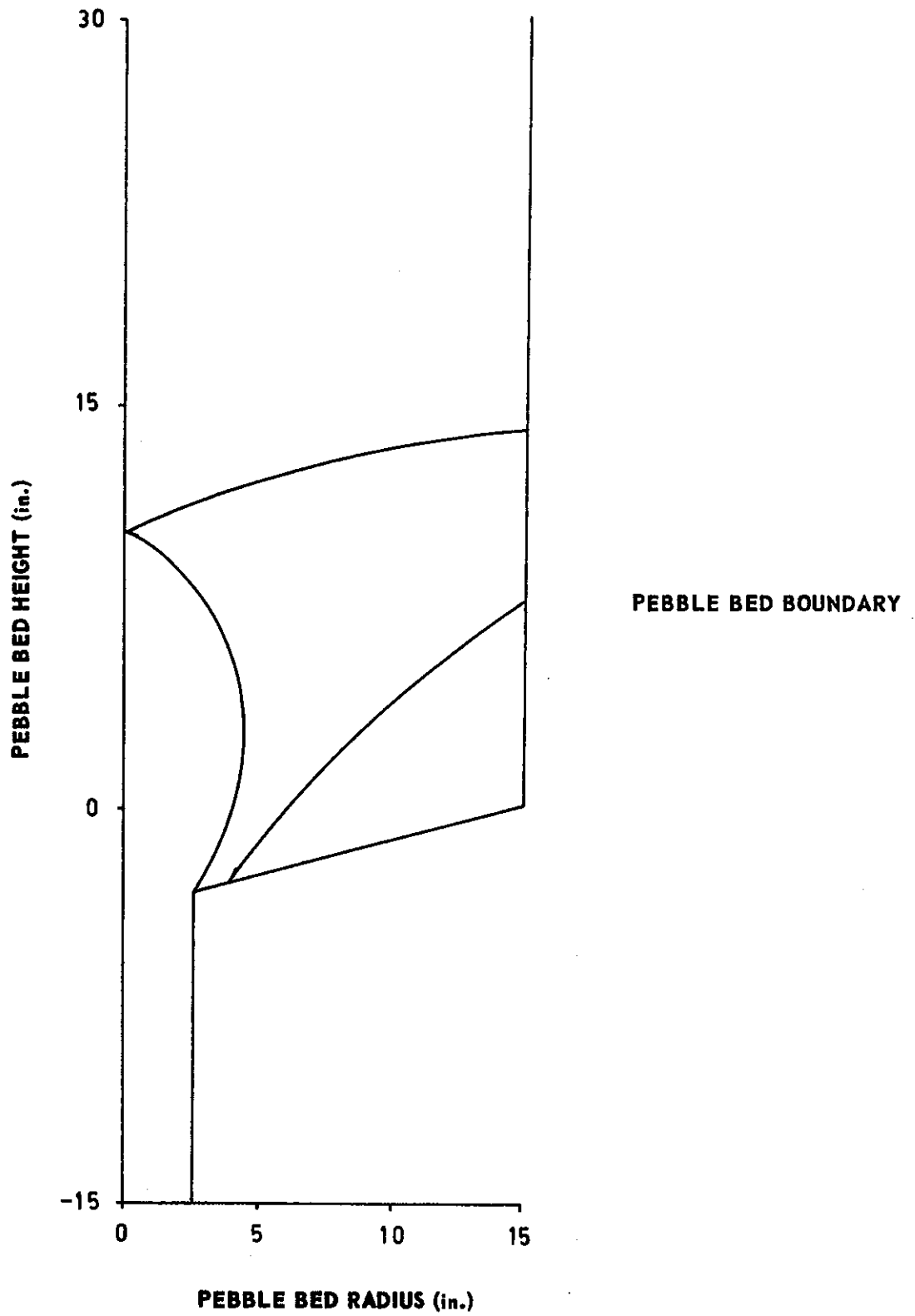

FIGURE 58. BASE ANGLE 15°, EXTRACTOR DIA. 5 in.

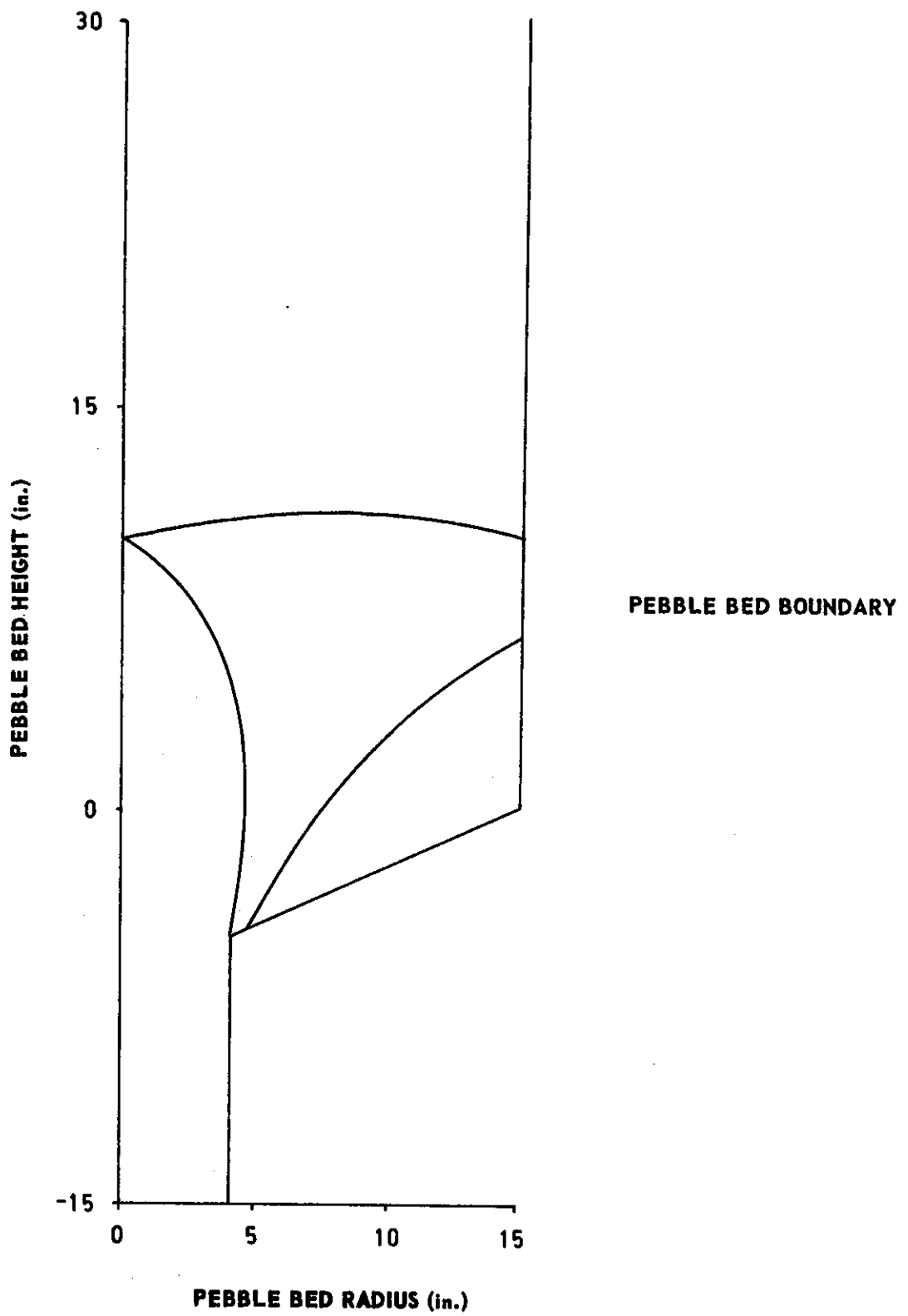

FIGURE 59. BASE ANGLE 25°, EXTRACTOR DIA. 8 in.

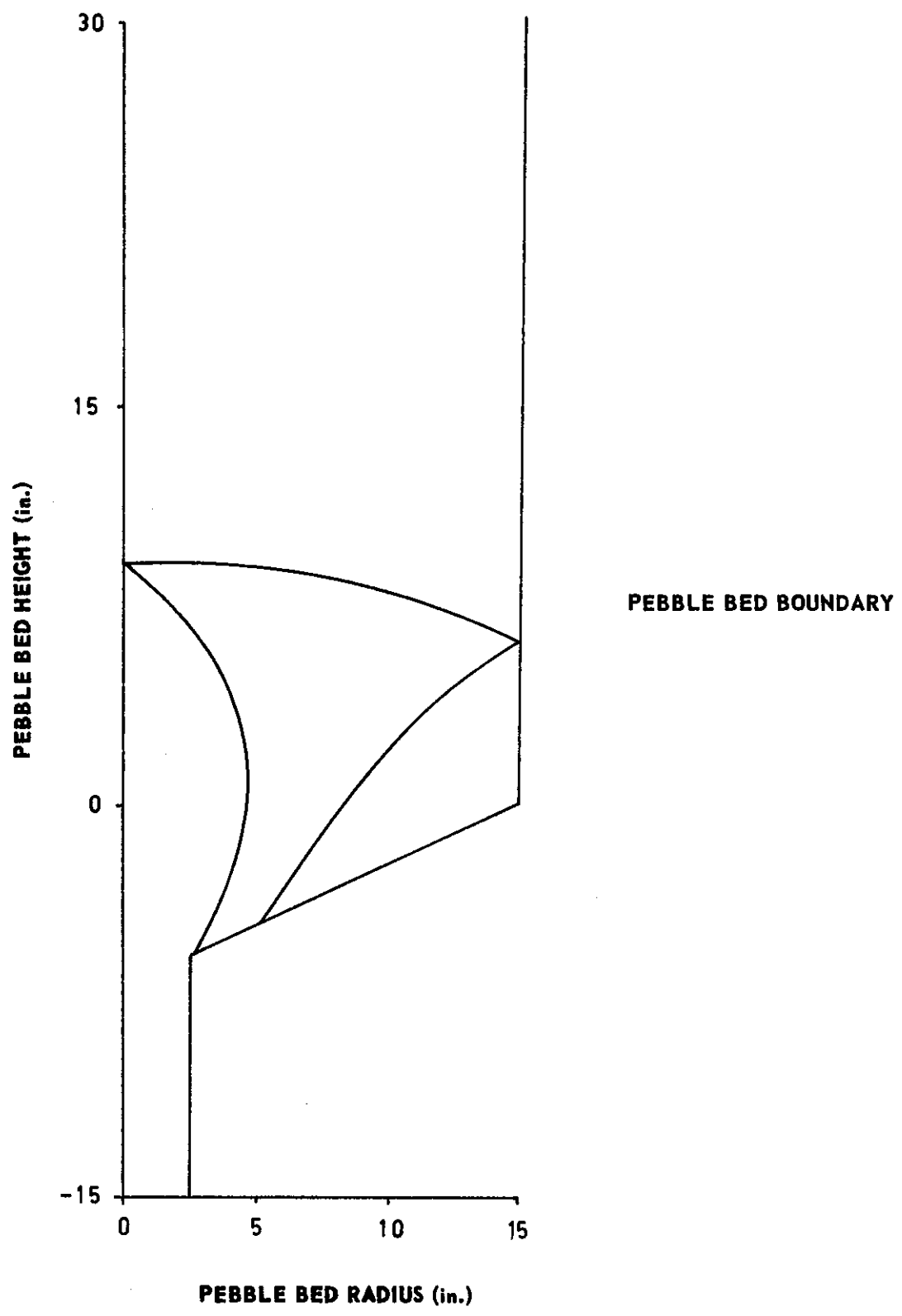

FIGURE 60. BASE ANGLE 25°, EXTRACTOR DIA. 5 in.

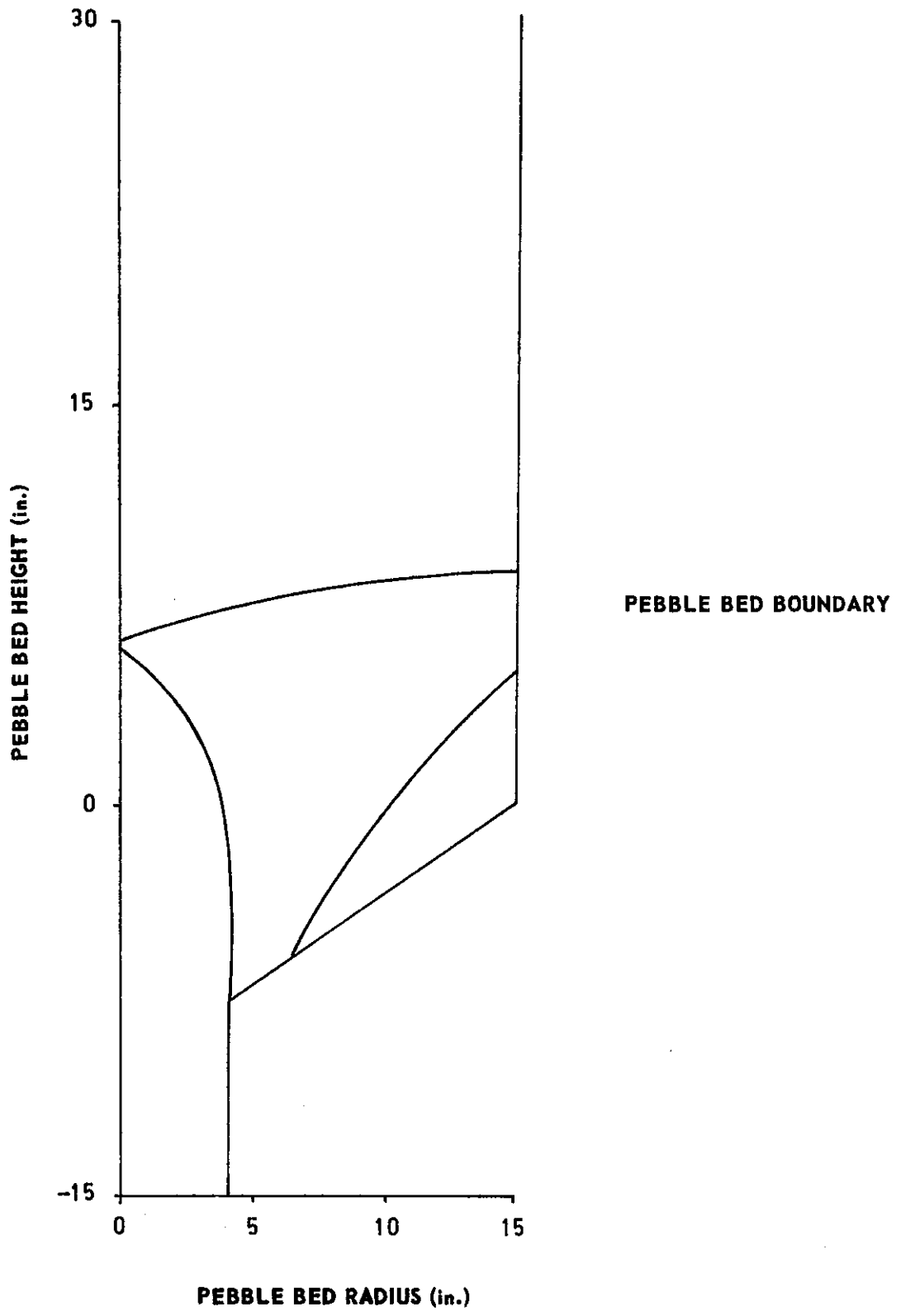

FIGURE 61. BASE ANGLE 35°, EXTRACTOR DIA. 8 in.

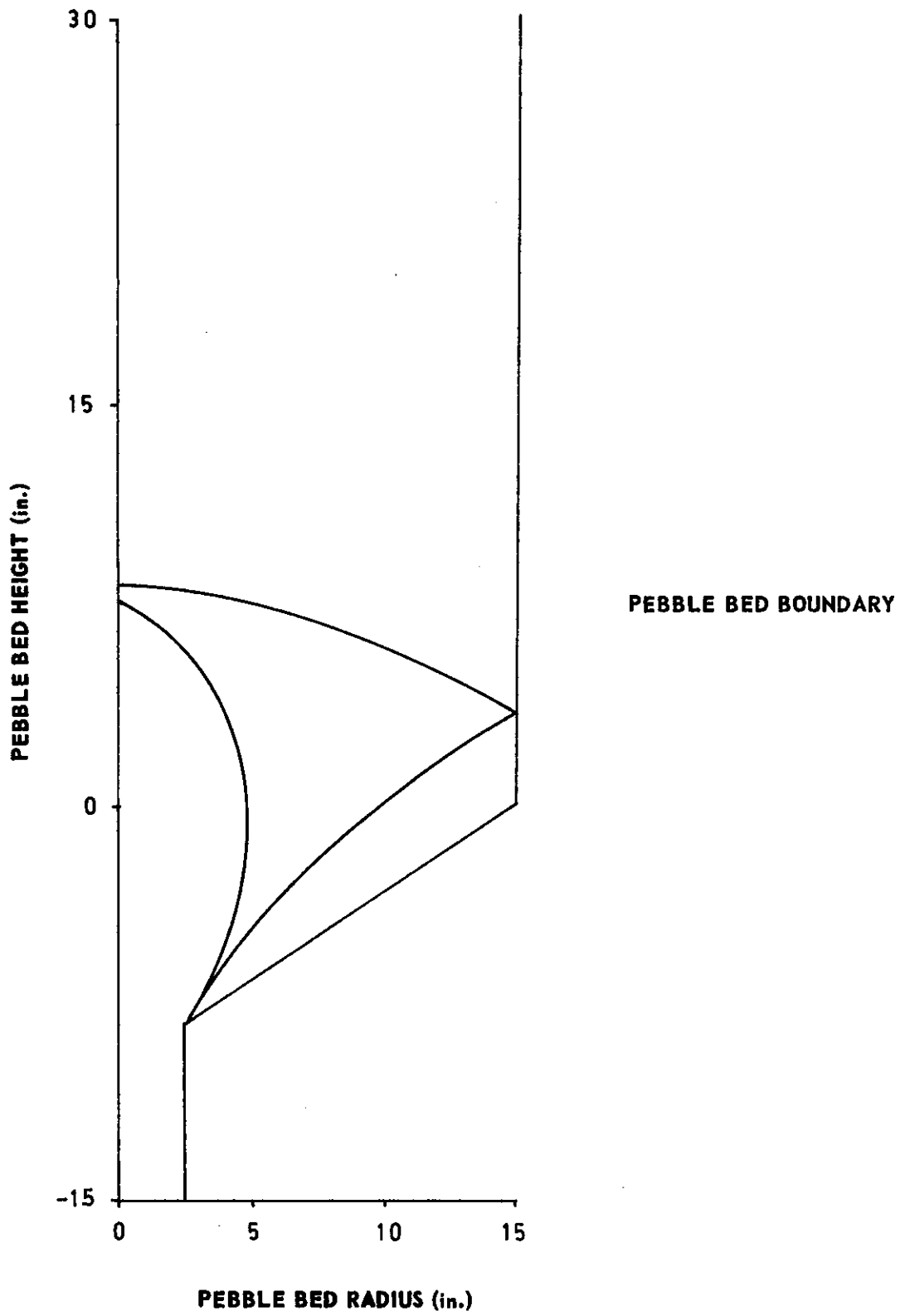

FIGURE 62. BASE ANGLE 35°, EXTRACTOR DIA. 5 in.

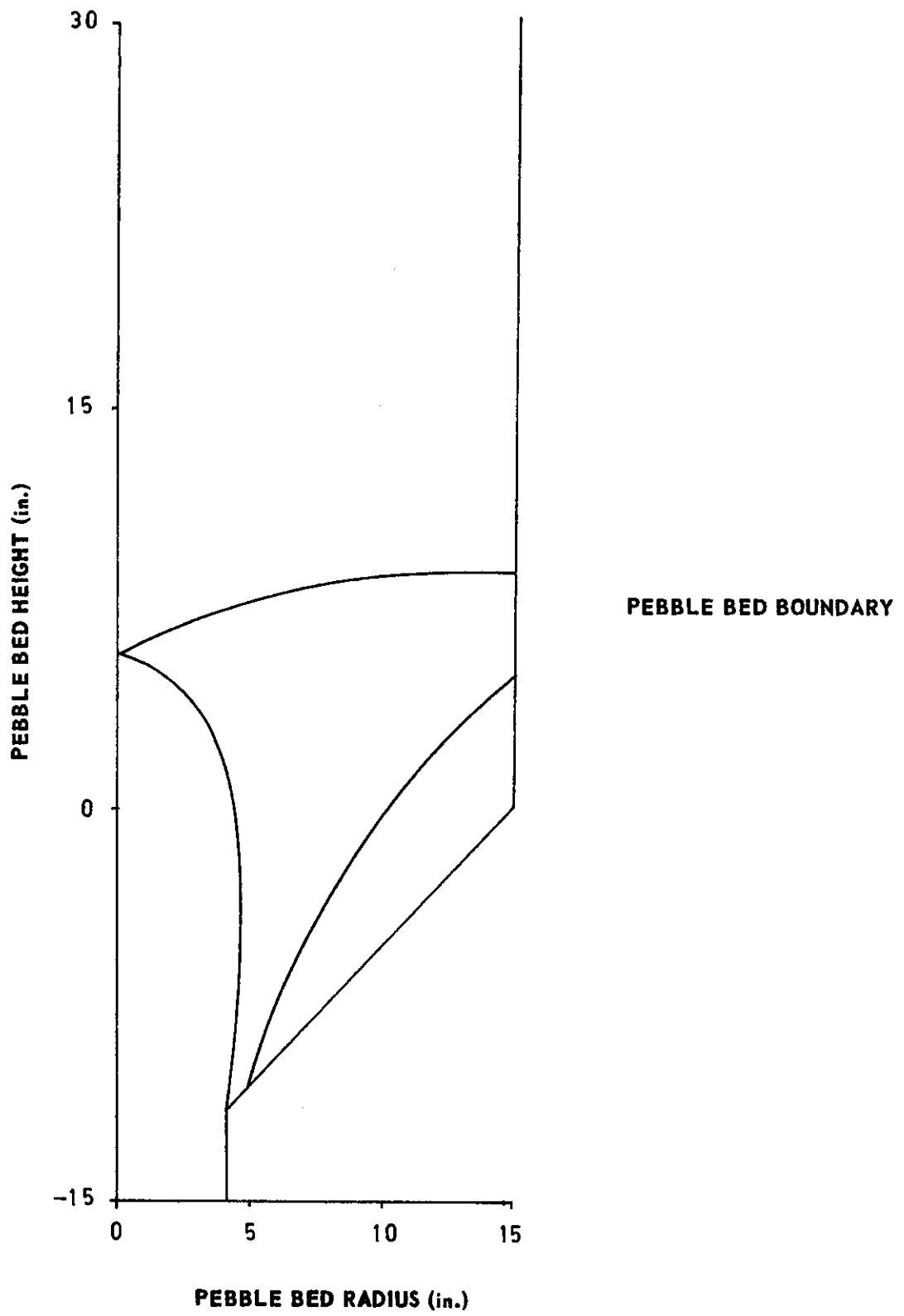

FIGURE 63. BASE ANGLE 45°, EXTRACTOR DIA. 8 in.

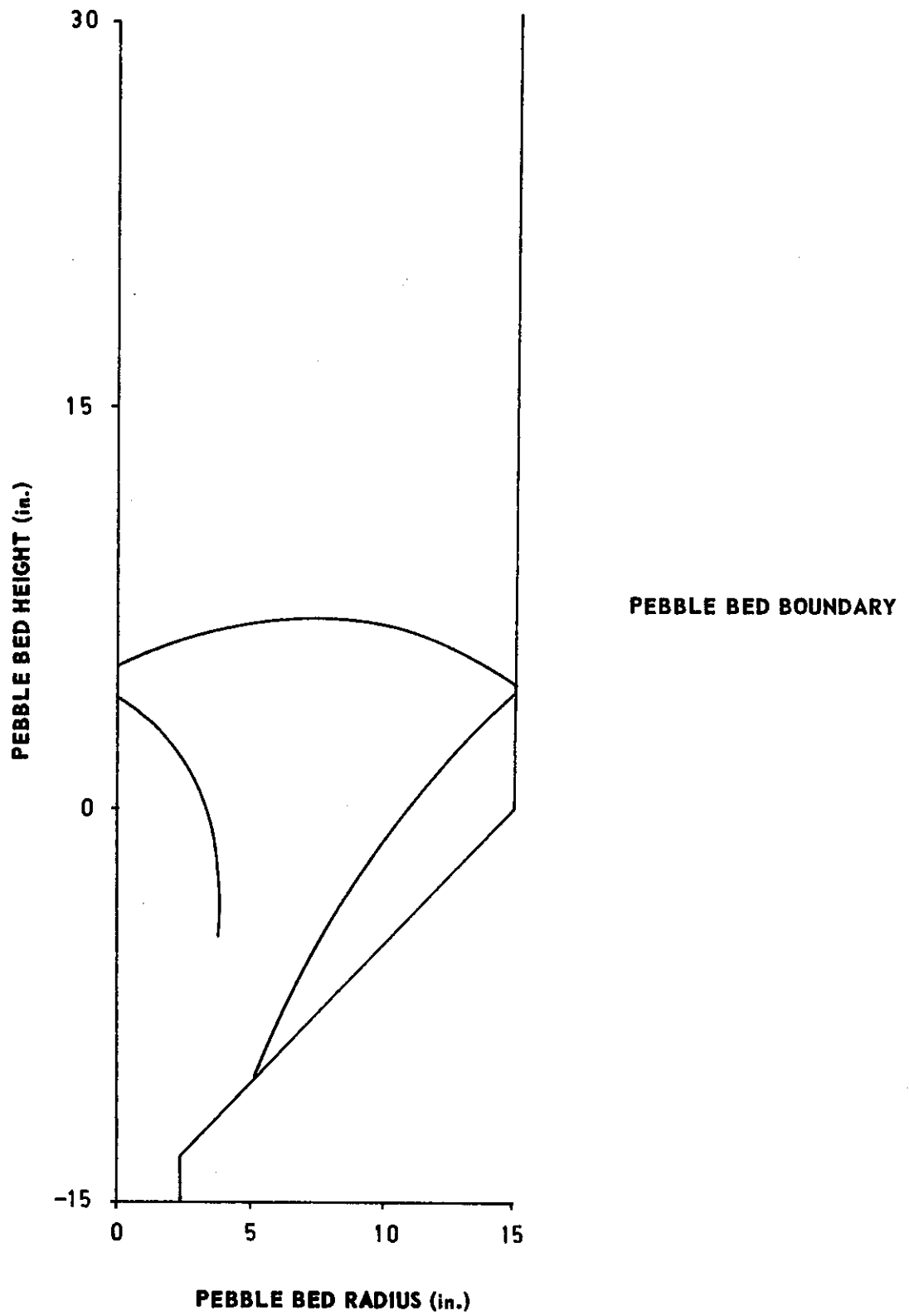

FIGURE 64. BASE ANGLE 45°, EXTRACTOR DIA. 5 in.

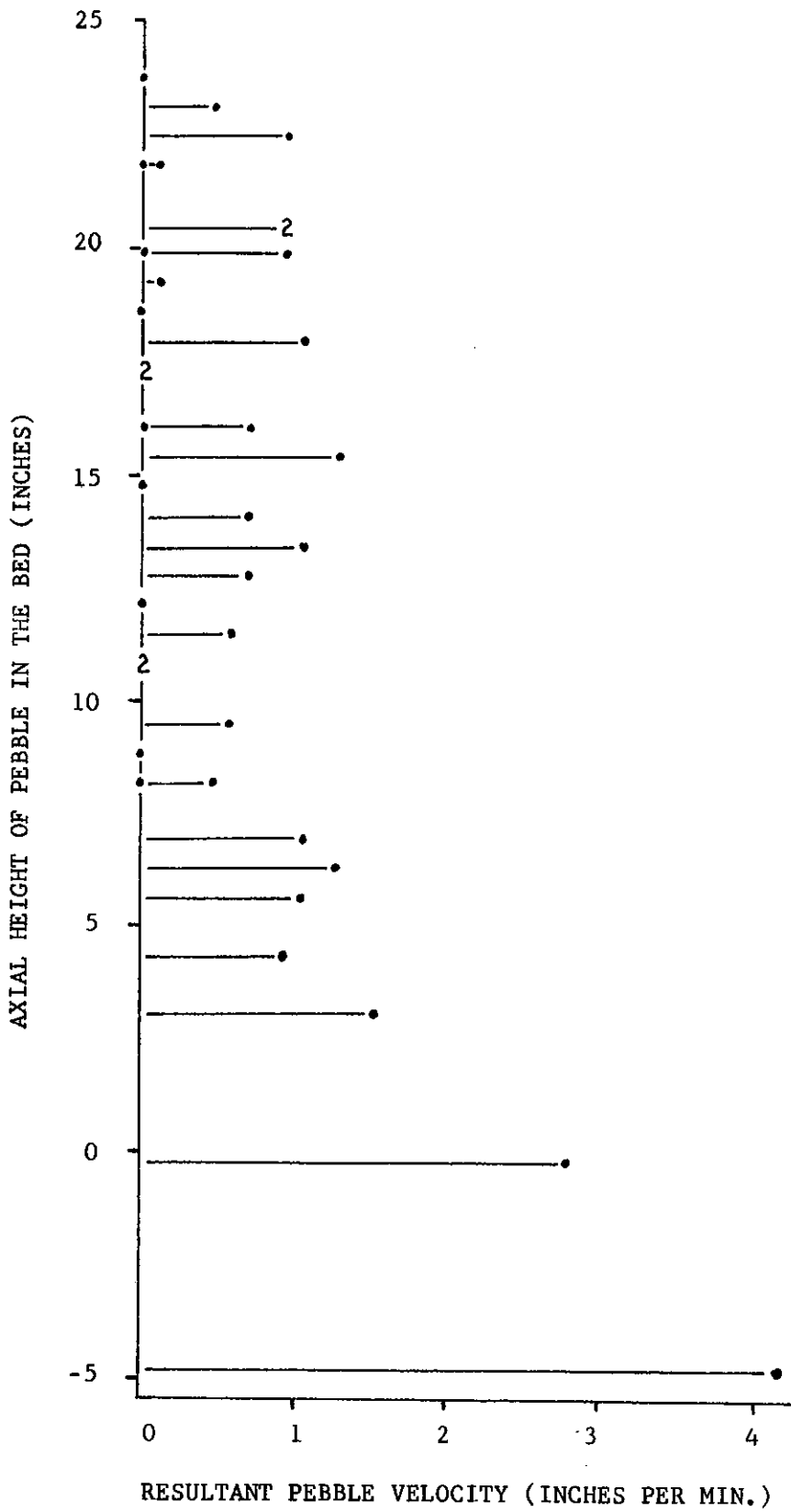

FIGURE 65. PLOT OF RESULTANT PEBBLE VELOCITY VERSUS PEBBLE AXIAL POSITION FOR TRIAL NUMBER 363

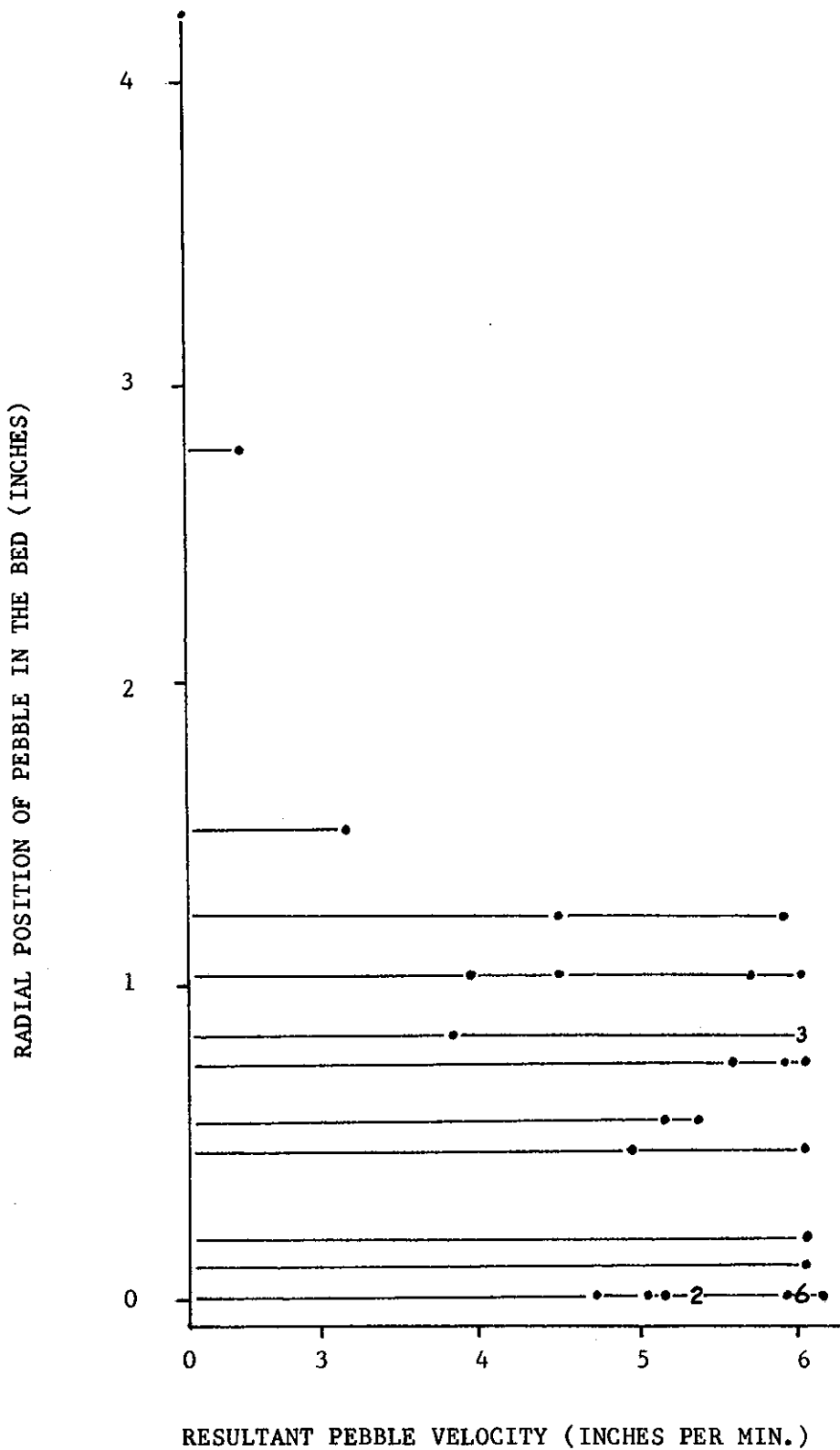
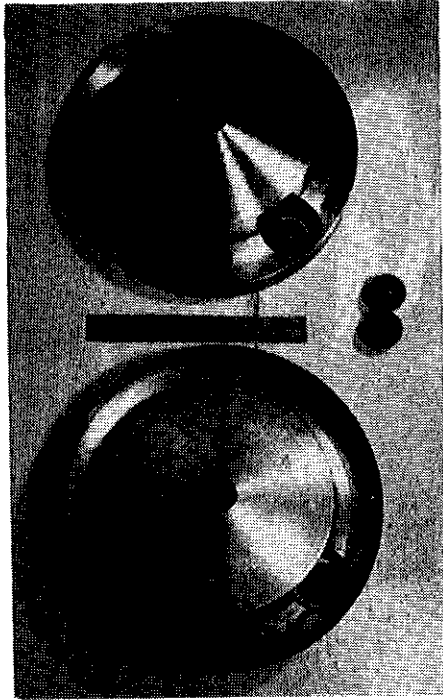
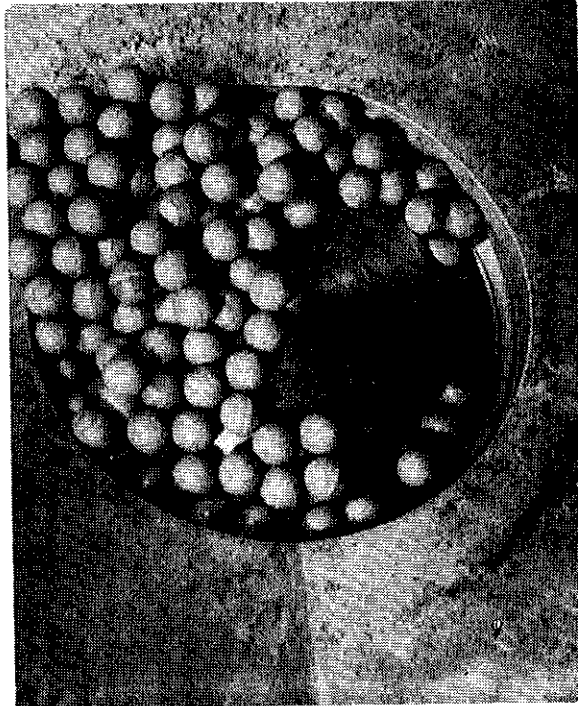

FIGURE 66. PLOT OF RESULTANT PEBBLE VELOCITY VERSUS PEBBLE RADIAL POSITION FOR TRIAL NUMBER 363



(a) Top - High Position Extractor
Bottom - Low Position Extractor



(b) 8 inch Extractor Showing Outlet and
0.75 inch Diameter Spherical Pebbles.

FIGURE 67. PEBBLE EXTRACTORS

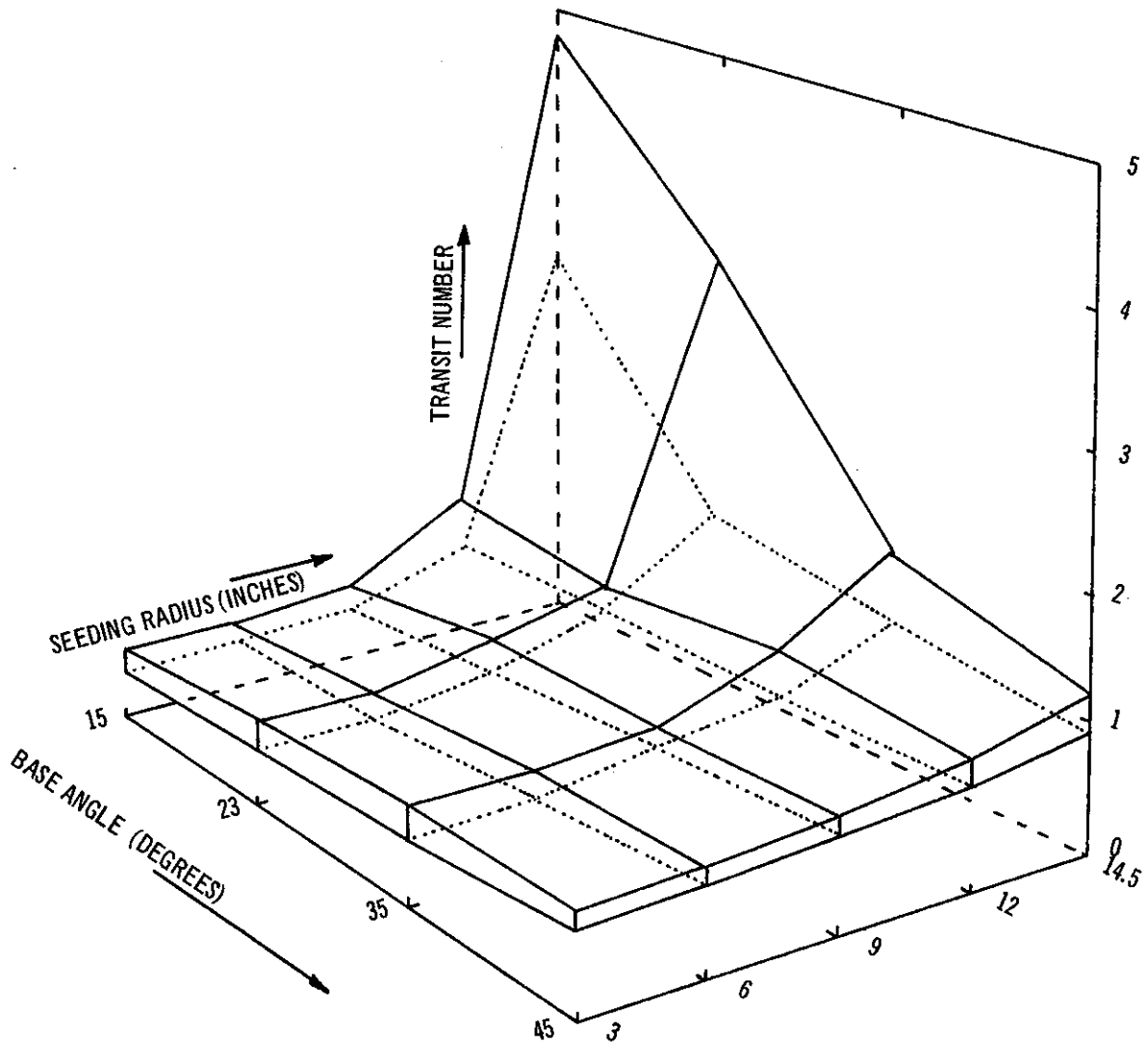

FIGURE 68. RANGE OF TRANSIT NUMBER SPECTRAL MEANS FOR VARYING BASE ANGLE AND SEEDING RADIUS

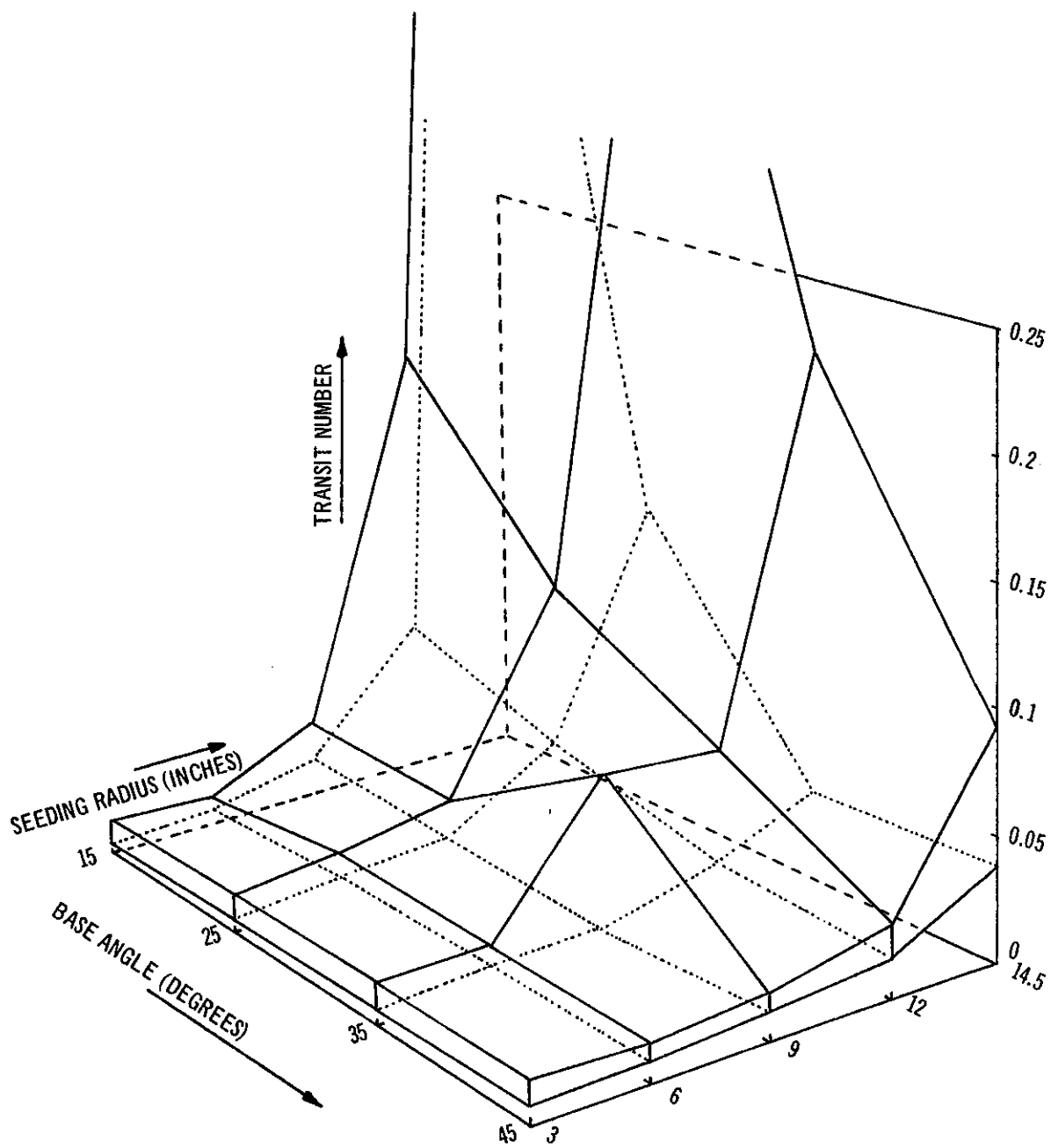

FIGURE 69. RANGE OF TRANSIT NUMBER SPECTRAL STANDARD DEVIATIONS FOR VARYING BASE ANGLE AND SEEDING RADIUS

FIGURES 70-82

TRANSIT NUMBERS VERSUS RADIAL SEEDING POSITIONS

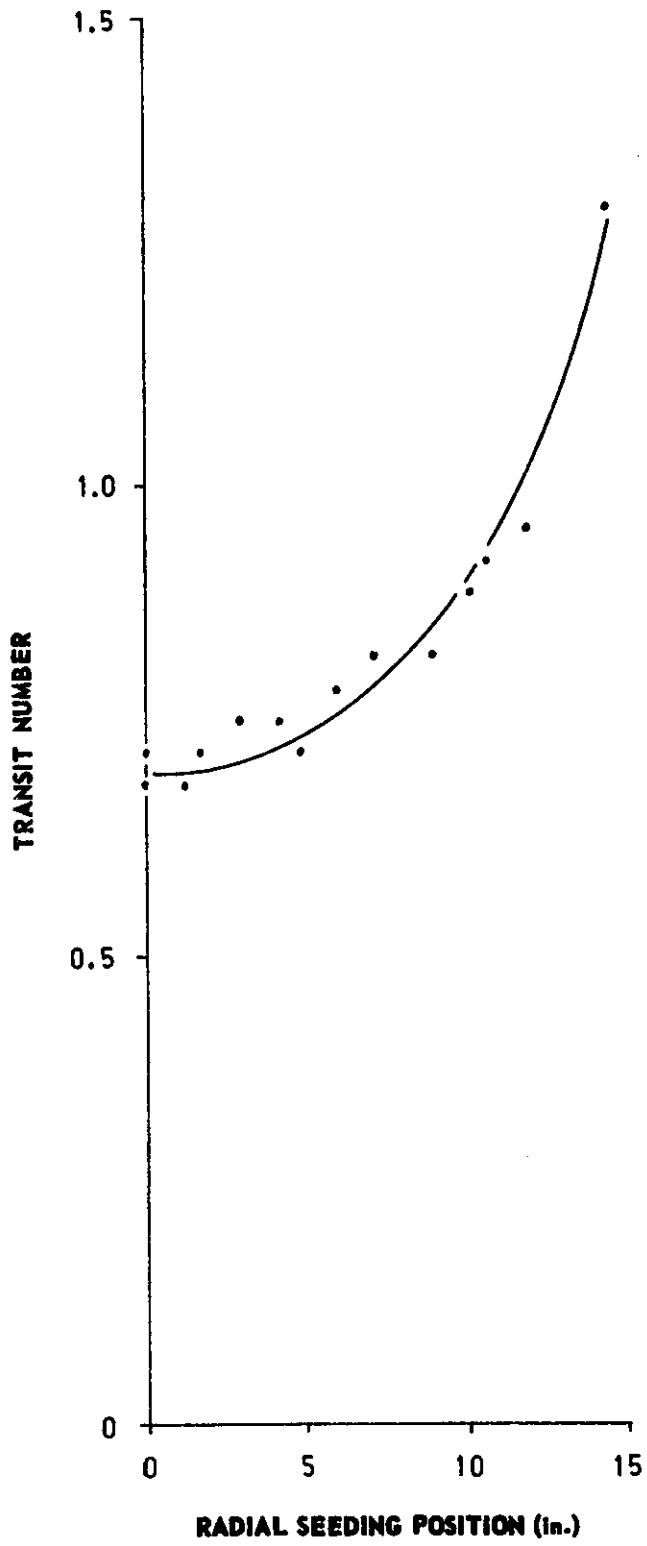

FIGURE 70. GROUP 18.

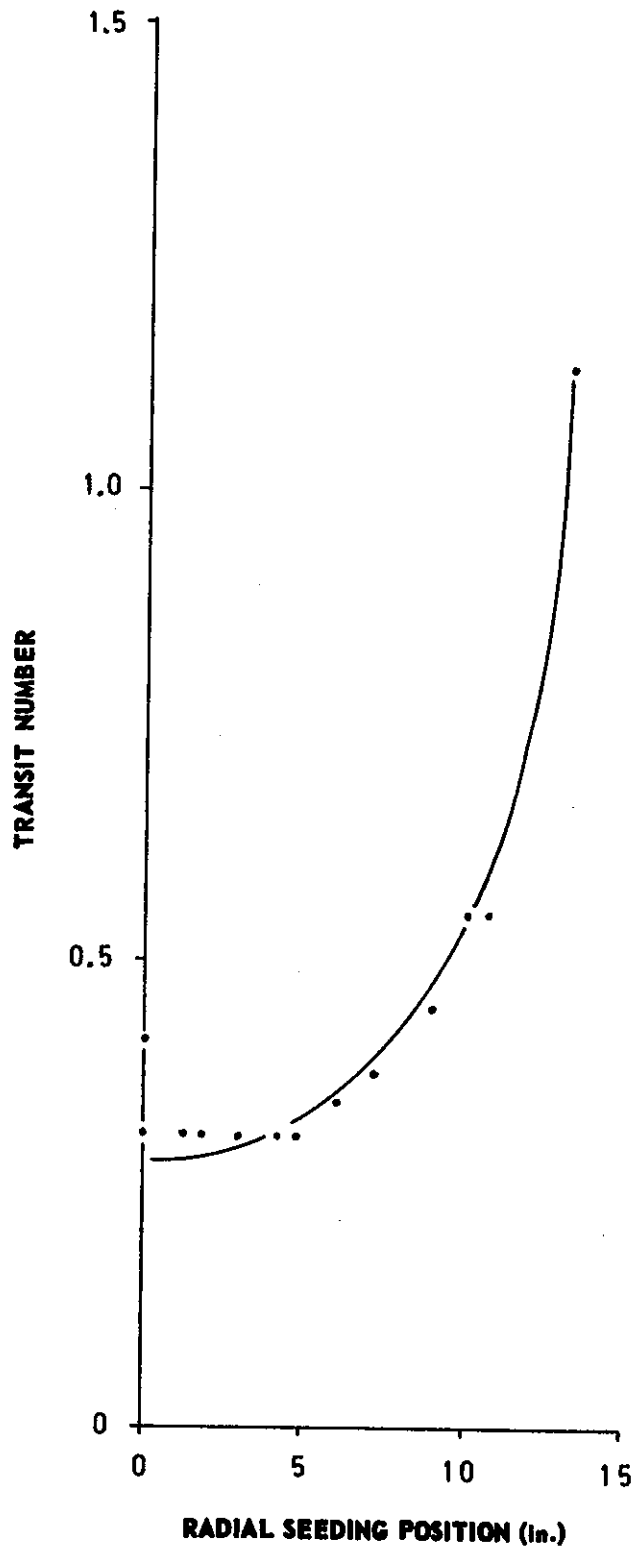

FIGURE 71. GROUP 22.

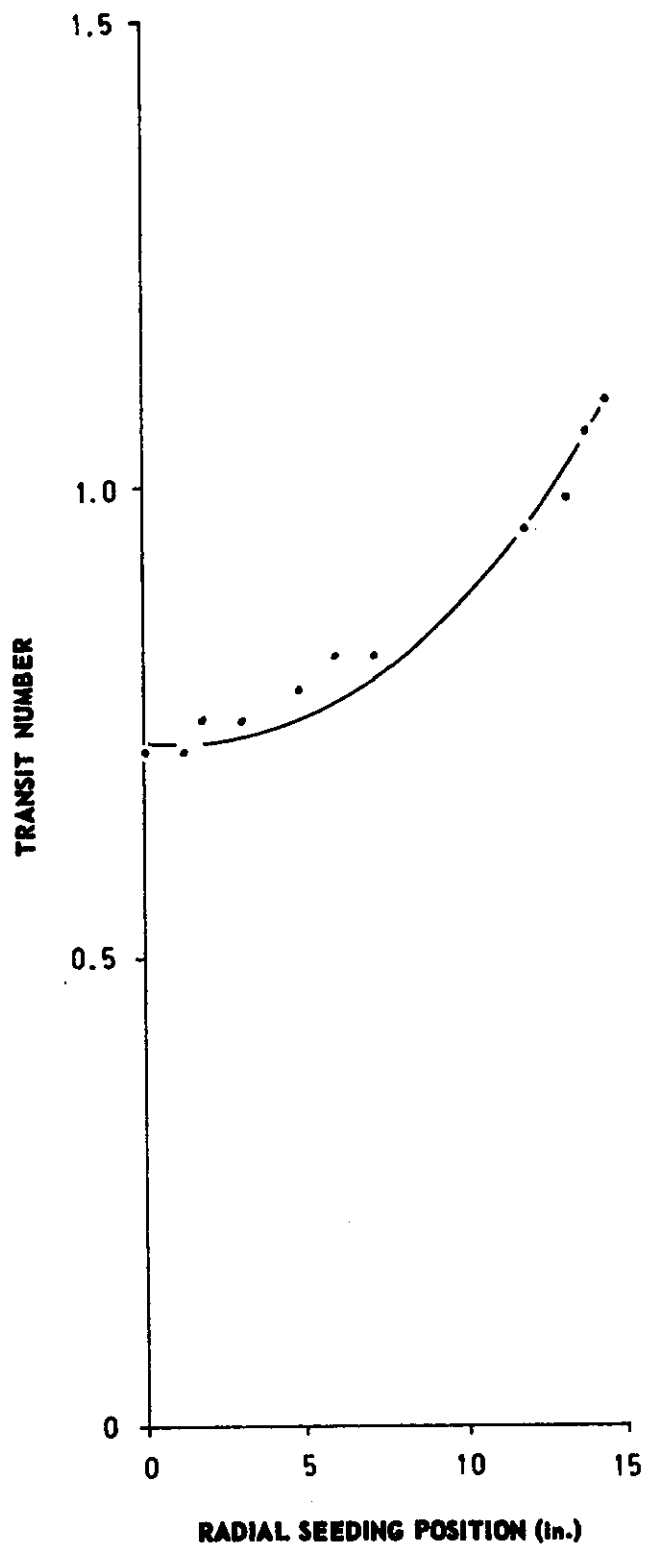

FIGURE 72. GROUP 34.

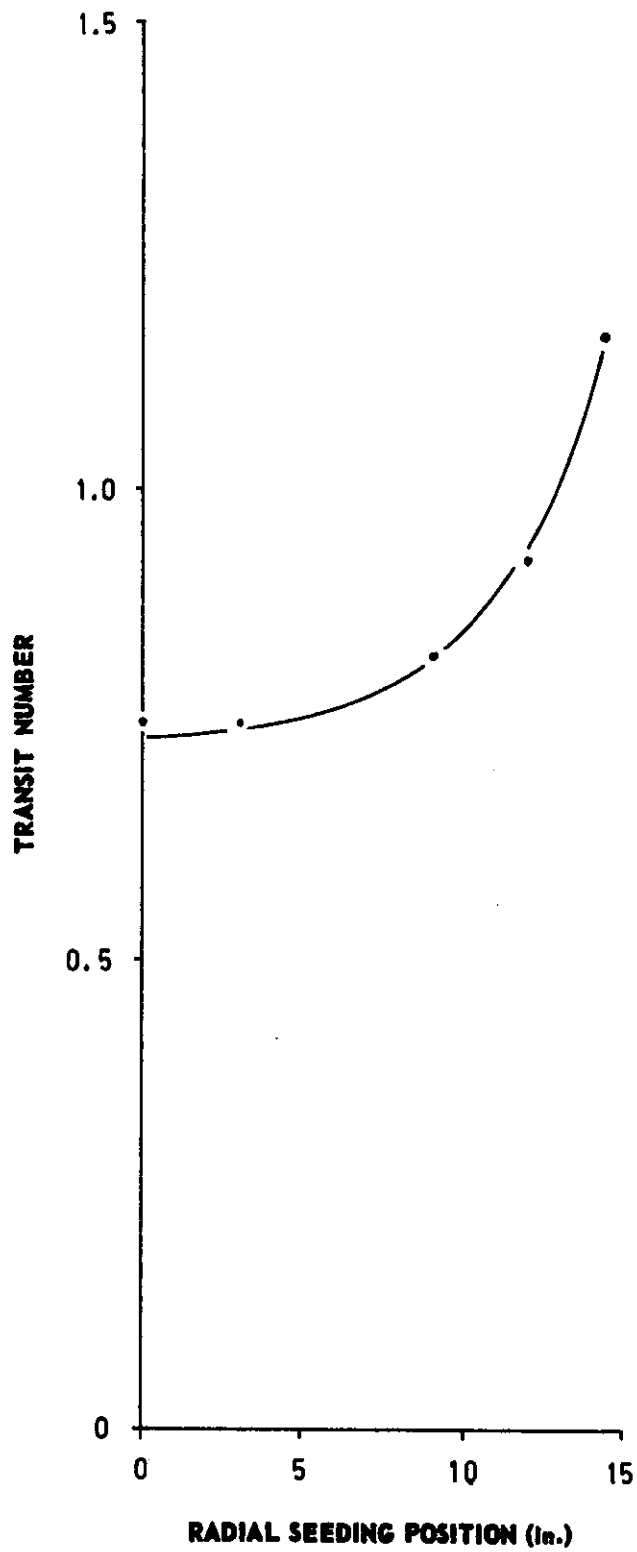

FIGURE 73. GROUP 35.

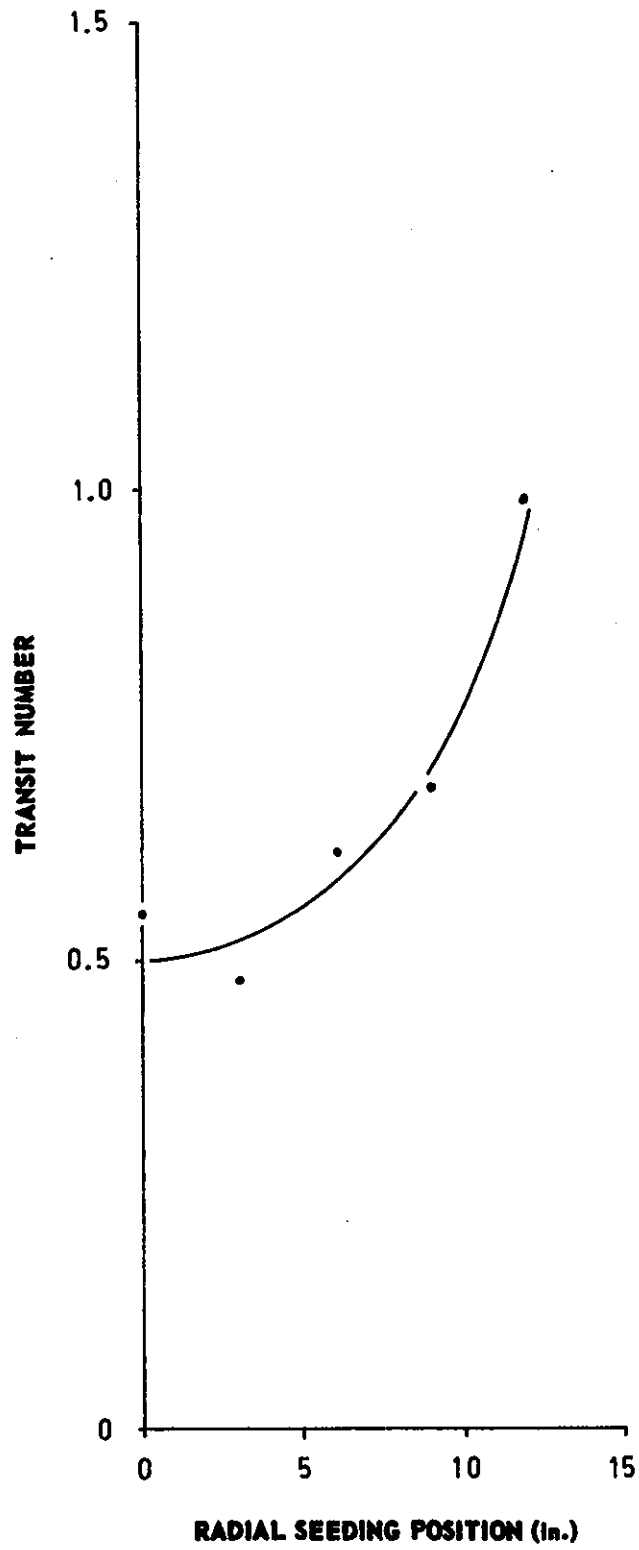

FIGURE 74. GROUP 36.

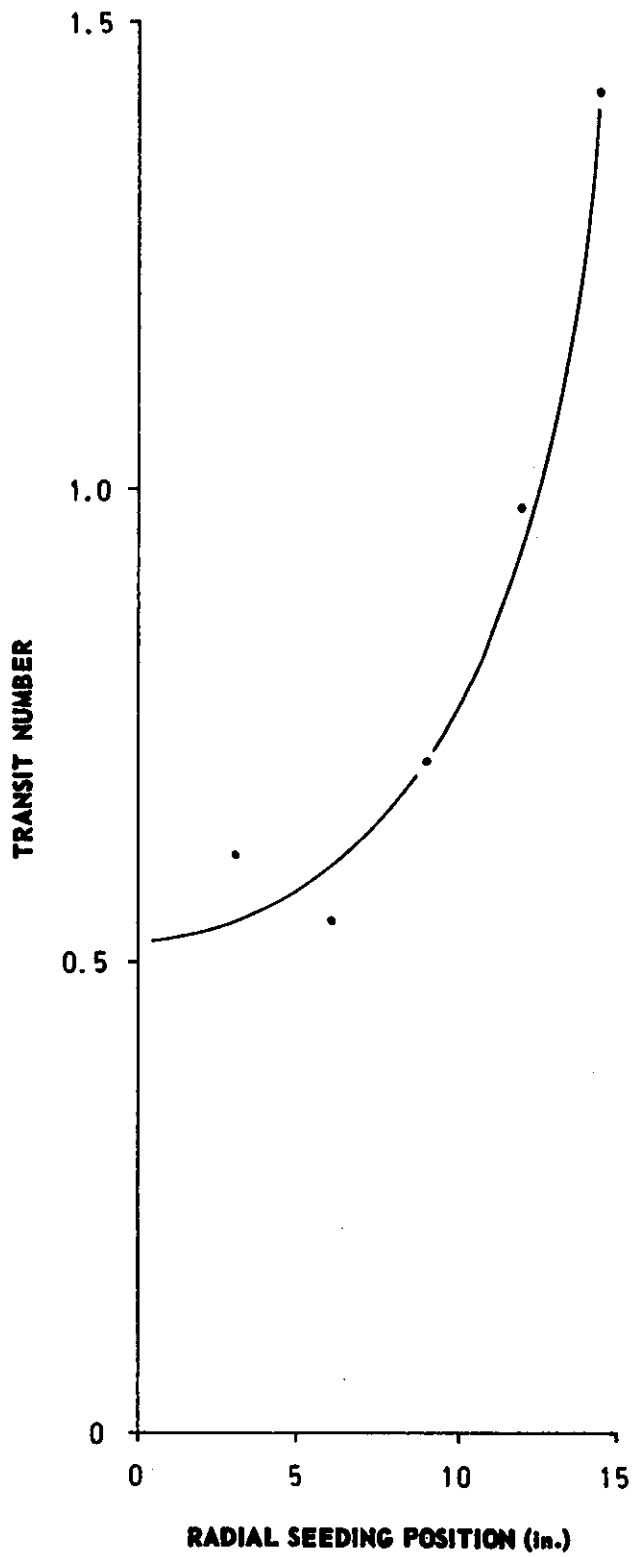

FIGURE 75. GROUP 37.

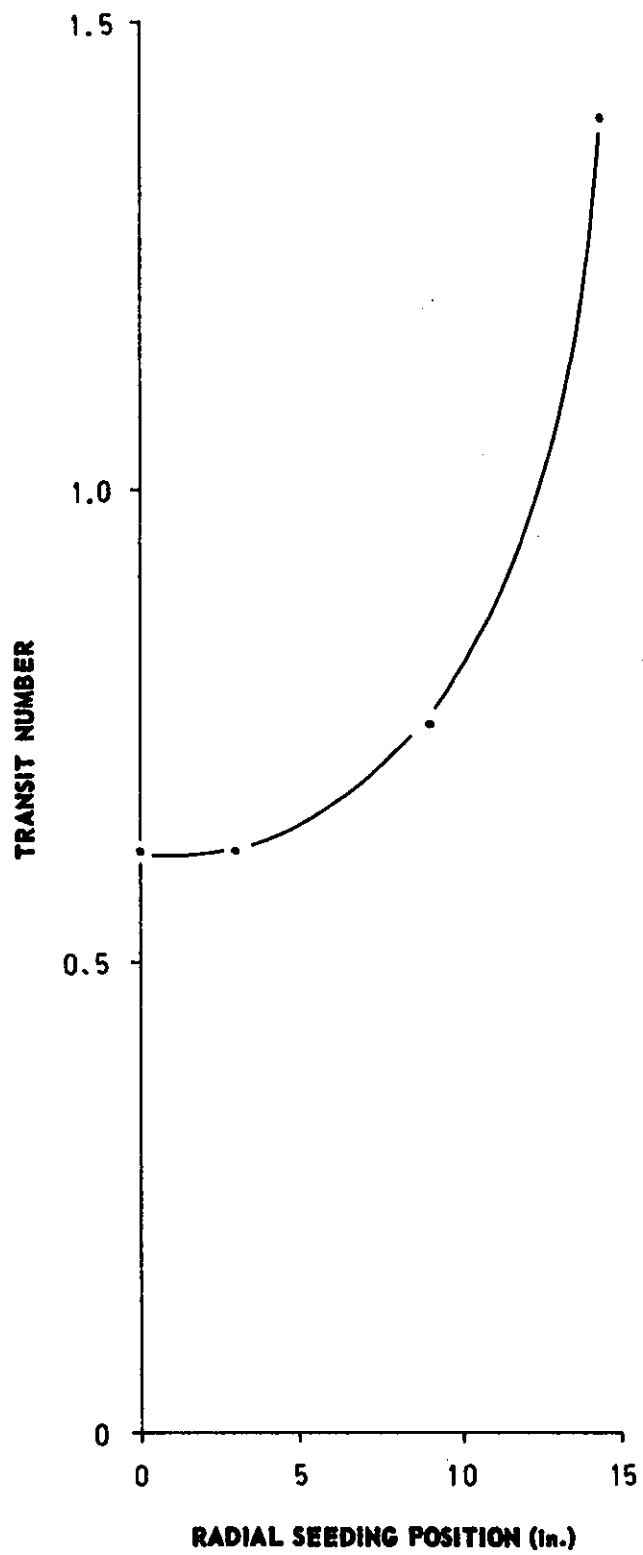

FIGURE 76. GROUP 38.

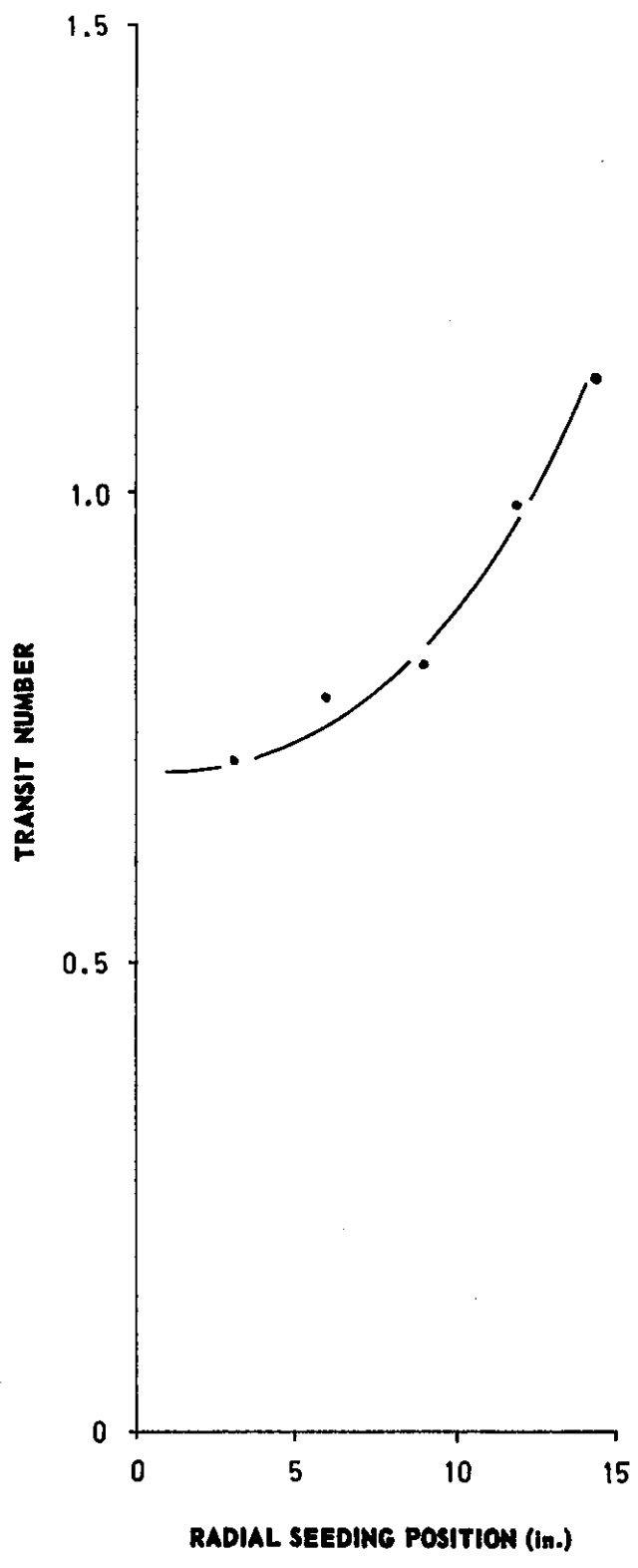

FIGURE 77. GROUP 39.

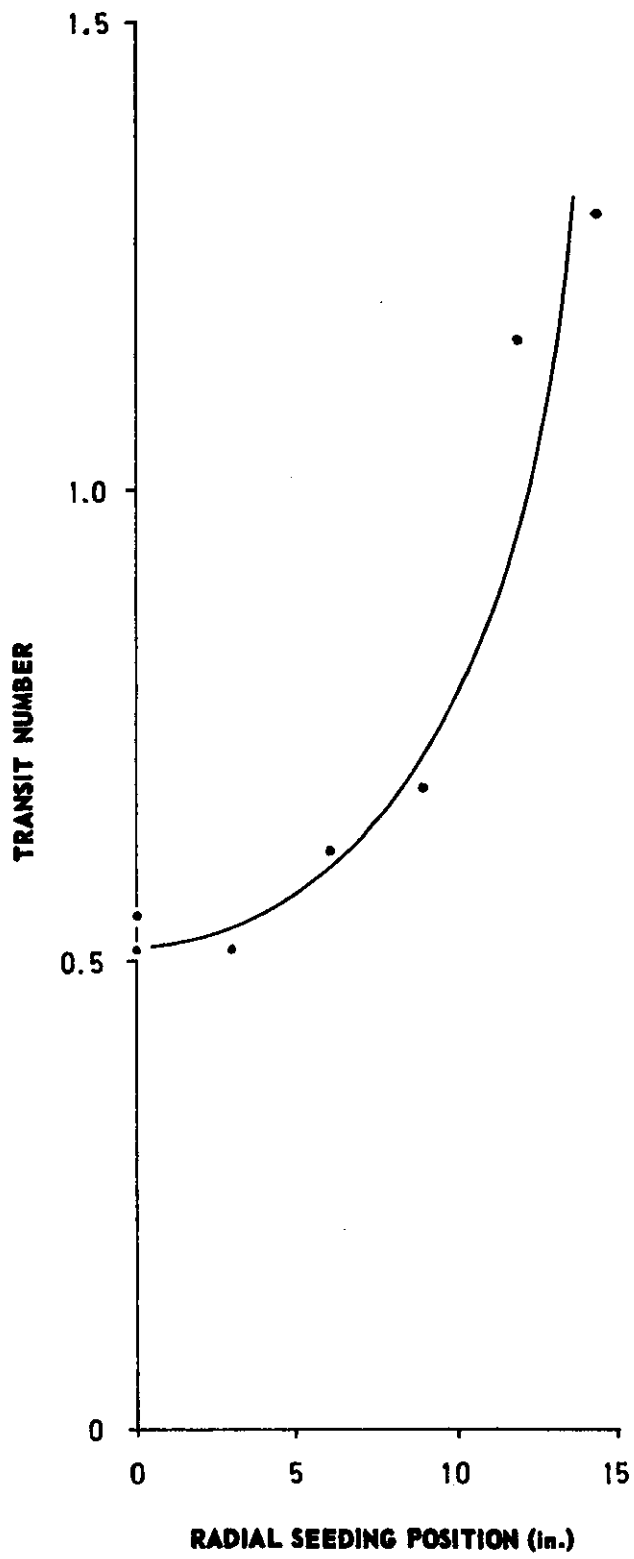

FIGURE 78.GROUP 40.

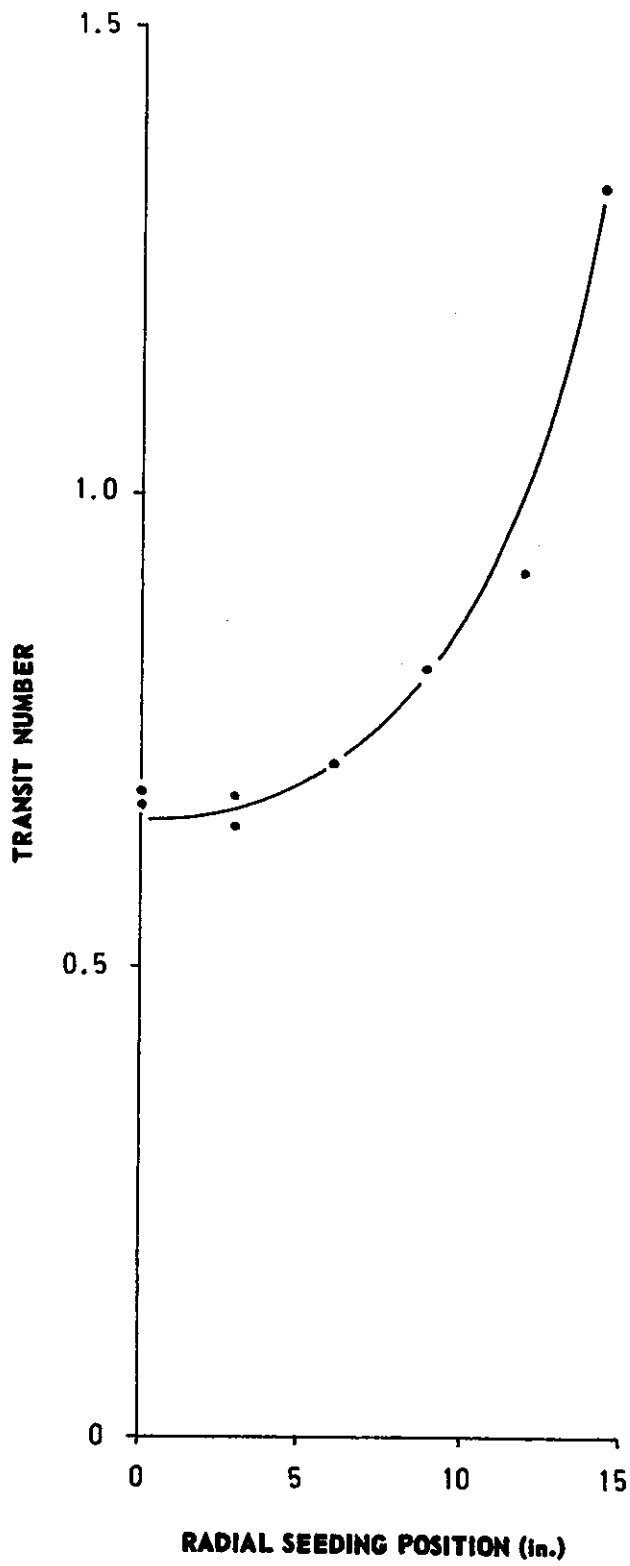

FIGURE 79. GROUP 41.

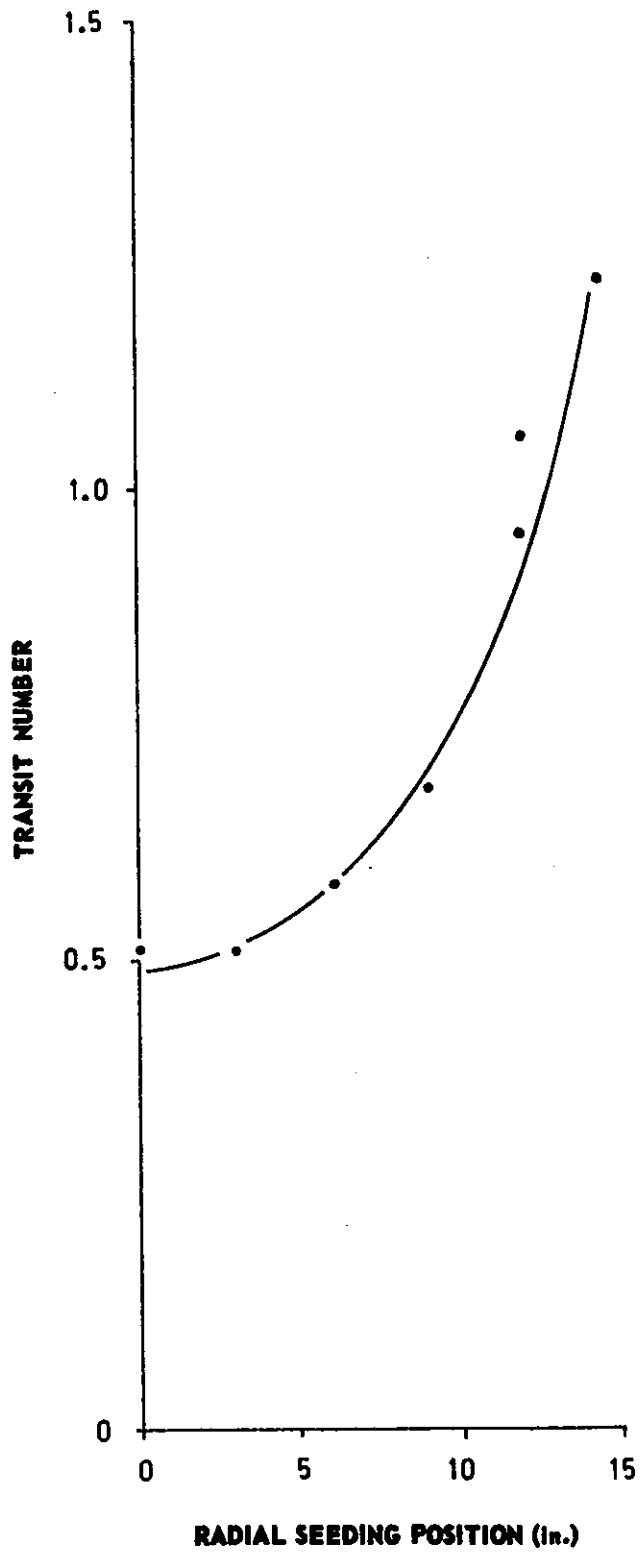

FIGURE 80. GROUP 42.

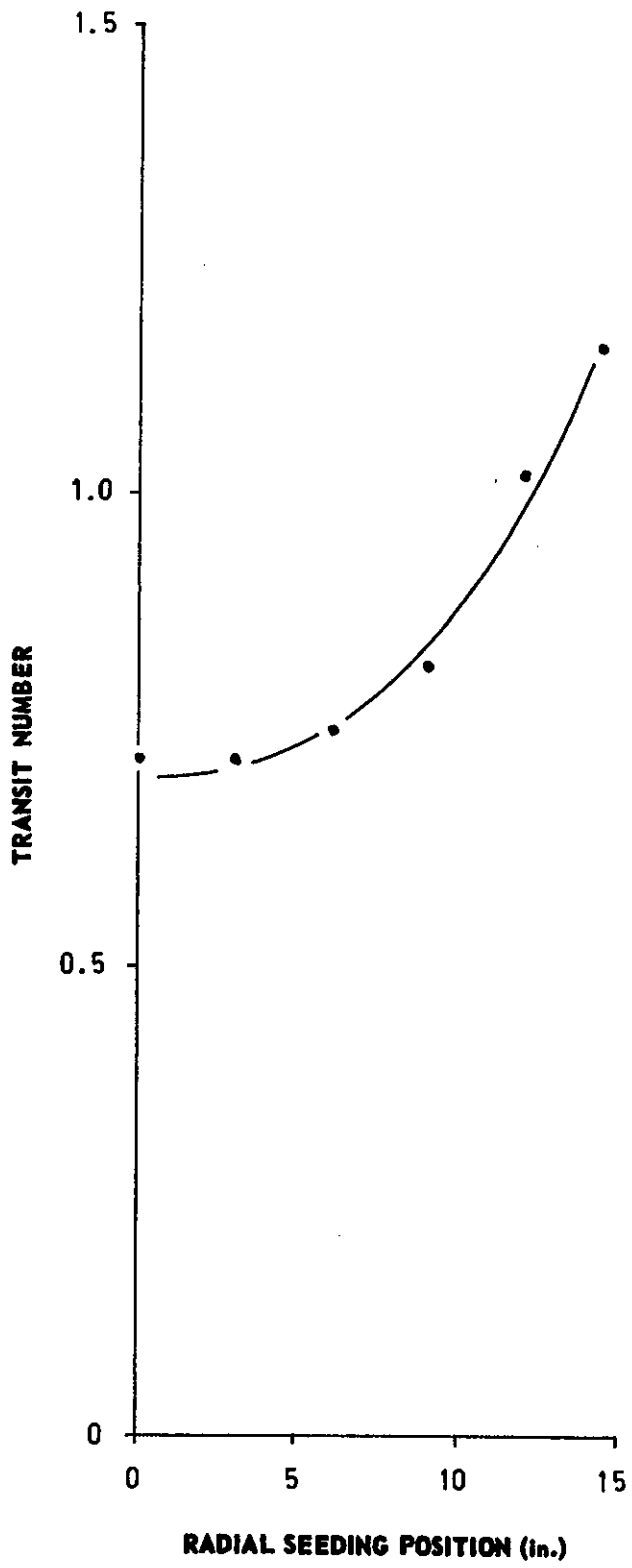

FIGURE 81. GROUP 43.

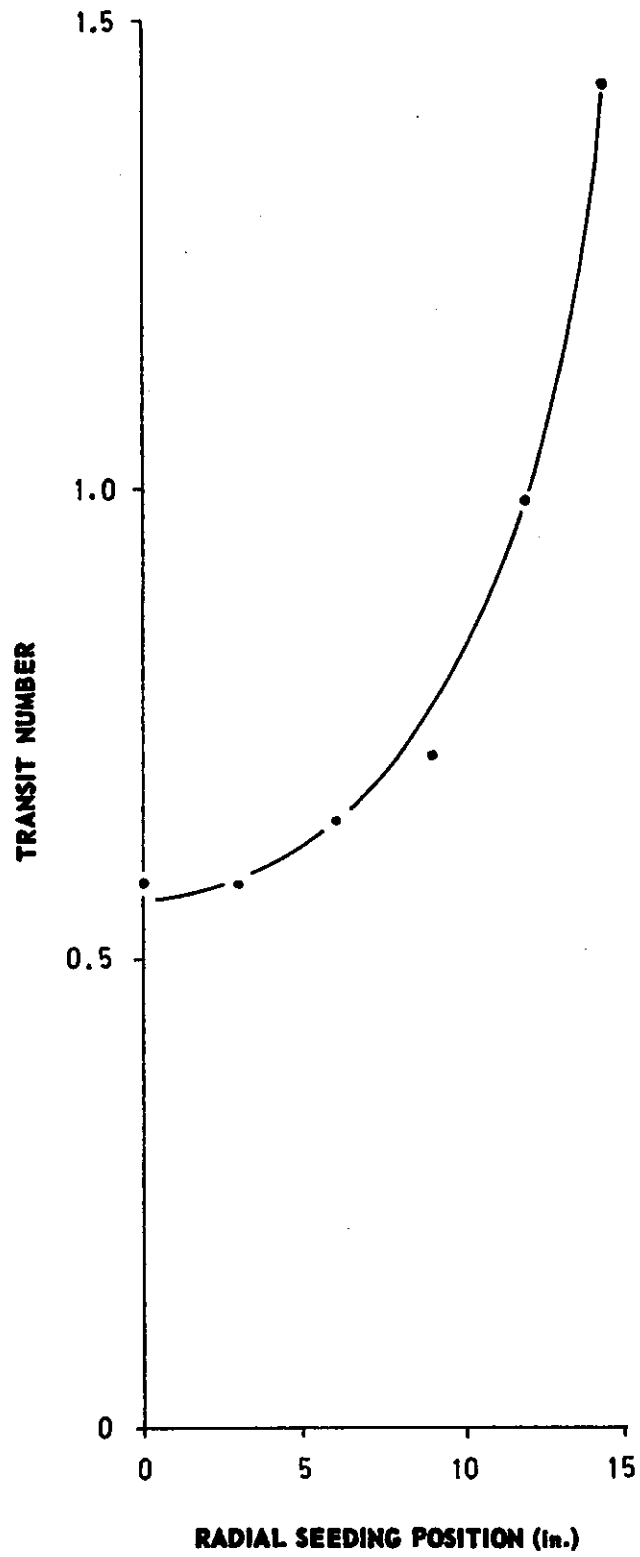

FIGURE 82. GROUP 44.

APPENDIX A

NOTATION

D Vessel diameter

D_p Pebble diameter

H Height of the cylindrical section of the pebble bed at the start of recirculation.

APPENDIX B
PAPER TAPE CODE

NUMERAL / SYMBOL	CODE
1	11101
2	11001
3	10000
4	01010
5	00001
6	10101
7	11100
8	01100
9	00011
0	01101
CR (CARRIAGE RETURN)	00010
SPACE	00100
NEGATIVE SIGN -	11000
POSITIVE SIGN +	10001
FIGURES	11011
LETTERS	11111
LINE FEED	01000

IN THE CODE,
1 = PUNCHED HOLE
0 = NO PUNCHED HOLE

APPENDIX C

EXAMPLE OF TRACKER PRINTED OUTPUT

TRIAL NUMBER							TRIAL DATE (1 MAY 1968)
HEADING RECORD	→	563	01568				
DATA RECORD	→	000020	249	288	248	①	MODE
		000040	245	288	248	1	
TIME	→	000060	245	288	248	1	
(SECONDS)		000080	245	288	248	1	
		000120	245	294	248	1	
		000100	245	294	248	1	
		000140	246	294	248	1	
		000160	246	294	248	1	
		000180	246	300	248	1	
THETA 1	→	000200	246	300	248	1	THETA 2
(VOLTS)		000220	246	300	248	1	(VOLTS)
		000240	246	305	248	1	
		000260	246	305	248	1	
		000280	246	306	248	1	
		000300	245	305	248	1	
		000320	246	310	248	1	
		000340	246	310	248	1	
HEIGHT	→						
(VOLTS)							

APPENDIX D

PROGRAM DC1 - PEBBLE TRACKING PROGRAM

C	1	DC1	
C	2	DC1	
C	3	DC1	
C	4	DC1	
C	5	DC1	
C	6	DC1	
C	7	DC1	
C	8	DC1	
C	9	DC1	
C	10	DC1	
C	11	DC1	
C	12	DC1	
C	13	DC1	
C	14	DC1	
C	15	DC1	
C	16	DC1	
C	17	DC1	
C	18	DC1	
C	19	DC1	
C	20	DC1	
C	21	DC1	
C	22	DC1	
C	23	DC1	
C	24	DC1	
C	25	DC1	
C	26	DC1	
C	27	DC1	
C	28	DC1	
C	29	DC1	
C	30	DC1	
C	31	DC1	
C	32	DC1	
C	33	DC1	
C	34	DC1	
C	35	DC1	
C	36	DC1	
C	37	DC1	
C	38	DC1	
C	39	DC1	

	START

AR	= RADIAL POSITION OF SEEDED PEBBLE (INCHES).
ATHET	= ANGULAR POSITION OF SEEDED PEBBLE (DEGREES).
AZ	= AXIAL POSITION OF SEEDED PEBBLE (INCHES).
BALT2	= NUMBER OF PEBBLES RECIRCULATED.
DELT	= TIME (MINUTES).
DI6	= PEBBLE BED HEIGHT (INCHES).
DI13	= SEEDING INVENTORY (PEBBLES).
DI14	= RECIRCULATION RATE (PEBBLES/MINUTE).
DI15	= EXIT INVENTORY (PEBBLES).
DI16	= BED INVENTORY (PEBBLES).
HEIGHT	= AXIAL POSITION OF SEEDED PEBBLE (VOLTS).
HT2	= AXIAL POSITION OF SEEDED PEBBLE (INCHES).
IAT	= TIME (SECONDS).
ID	= TRIAL PARAMETERS.
IMAX	= NUMBER OF DATA RECORDS ON PAPER TAPE.
IT	= CONTINUOUS TIME (SECONDS).
ITIME	= CONTINUOUS TIME ON PAPER TAPE (SECONDS).
JAL	= NUMBER OF SELECTED RECORDS.
MAXLE	= NUMBER OF RECORDS ON TAPE LESS EXTRANEIOUS RECORDS.
OT	= RADIAL COORDINATE (Y AXIS) OF SEEDED PEBBLE (INCHES).
PT	= RADIAL COORDINATE (X AXIS) OF SEEDED PEBBLE (INCHES).
RAD	= RADIAL POSITION OF SEEDED PEBBLE (INCHES).
RD2	= RADIUS FOR EACH SELECTED RECORD (INCHES).
SDI	= SEEDED PEBBLE TRANSIT NUMBER.
T1	= TIME FOR EACH SELECTED RECORD (MINUTES).
T3	= 10 TIMES THE ANGULAR POSITION (DEGREES) OF THE SEEDED PEBBLE, FIRST USAGE.
T3	= ANGULAR POSITION OF THE SEEDED PEBBLE (RADIAN), SECOND USAGE.
T4	= 10 TIMES THE ANGULAR POSITION (DEGREES) OF THE SEEDED PEBBLE, FIRST USAGE.
T4	= ANGULAR POSITION OF THE SEEDED PEBBLE (RADIAN), SECOND USAGE.
THET2	= ANGULAR POSITION OF THE SEEDED PEBBLE (DEGREES).
THETA	= ANGULAR POSITION OF THE SEEDED PEBBLE (DEGREES).
THETA1	= ANGULAR POSITION OF THE SEEDED PEBBLE (VOLTS).
THETA2	= ANGULAR POSITION OF THE SEEDED PEBBLE (VOLTS).

```

RAD(I) = SQRT(OT**2+PT**2)
THETA(I) = ATAN2(PT,OT)*180./PI
Z(I)=HEIGHT(I)
Z(I)=(79.5-Z(I)/10.)*0.5
1 CONTINUE
C
IF(ID(2).EQ.1)BD=1.0
IF(ID(2).EQ.2)BD=0.75
HOB = ID(6)
IF(ID(9).EQ.1)BA=15,
IF(ID(9).EQ.2)BA=25,
IF(ID(9).EQ.3)BA=35,
IF(ID(9).EQ.4)BA=45,
DO 4005 I=1,IMAX
C IS PEBBLE HIGHER THAN PEBBLE BED HEIGHT OR LOWER THAN THE
C BASE CONE VERTEX OR OUTSIDE THE VESSEL OR IS PEBBLE DIRECTLY
C BELOW ANY PART OF THE CONE?
IF(Z(I).GT.HOB.OR.Z(I).LT.(-15.*TAN(2.*PI*BA/360.)).OR.RAD(I).GT.1DC1
15.-BD/2..OR.
22.*PI*BA/360.))+15.-BD/(2.*SIN(2.*PI*BA/360.)))Z(I)=888.88
4005 CONTINUE
C
DELETE ALL EXTRANEIOUS RECORDS
K1 = 0
DO 3 I = 1,IMAX
IF(Z(I).EQ.888.88)GO TO 3
K1 = K1+1
AZ(K1)=Z(I)
AR(K1) = RAD(I)
ATHET(K1) = THETA(I)
IAT(K1) = ITIME(I)
MAXLE = K1
3 CONTINUE
C CONVERT TAPE TIME (SECS) TO CONTINUOUS TIME (SECS).
IT(1) = IAT(1)
DO 500 I=2,MAXLE
IF(IAT(I)-IAT(I-1))501,501,502
502 IDX = IAT(I)-IAT(I-1)
GO TO 500
501 IT(I) = IT(I-1)+IAT(I)

```

DC1 118
DC1 119
DC1 120
DC1 121
DC1 122
DC1 123
DC1 124
DC1 125
DC1 126
DC1 127
DC1 128
DC1 129
DC1 130
DC1 131
DC1 132
DC1 133
DC1 134
DC1 135
DC1 136
DC1 137
DC1 138
DC1 139
DC1 140
DC1 141
DC1 142
DC1 143
DC1 144
DC1 145
DC1 146
DC1 147
DC1 148
DC1 149
DC1 150
DC1 151
DC1 152
DC1 153
DC1 154
DC1 155
DC1 156

```

IT(I) = IT(I-1)+IDX
500 CONTINUE
C      CONVERT CONTINUOUS TIME (SECS) TO CONTINUOUS TIME (MINS).
DO 406 I=1,MAXLE
TIME(I) = IT(I)
406 TIME(I) = TIME(I)/60.
C
C      CALCULATE PEBBLE VELOCITIES
C      -----
DO 403 I=2,MAXLE
DELT = TIME(I)-TIME(I-1)
VL(I) = (ATHET(I)-ATHET(I-1))/DELT
VR(I) = -(AR(I)-AR(I-1))/DELT
VA(I) = -(AZ(I)-AZ(I-1))/DELT
VC(I) = -((AR(I)*ATHET(I)*PI/180.)-(AR(I-1)*ATHET(I-1)*PI/180.))/
1 DELT
403 VO(I) = SQRT(VR(I)**2+VA(I)**2+VC(I)**2)
C
C      SELECT RECORDS FOR PRINTOUT AT INTERVALS OF APPROXIMATELY
C      -----
C      1000 RECIRCULATED PEBBLES
C      -----
IM = (1000./DI14)*3.
J=0
DO 400 I=2,MAXLE,IM
J=J+1
T1(J)=TIME(I)
BAL2(J) = AR(I)
RD2(J) = AZ(I)
HT2(J) = VL(I)
VL2(J) = VR(I)
VR2(J) = VA(I)
VA2(J) = VC(I)
VC2(J) = VO(I)
VO2(J) = ATHET(I)
THET2(J) = ATHET(I)

```

DC1 157
DC1 158
DC1 159
DC1 160
DC1 161
DC1 162
DC1 163
DC1 164
DC1 165
DC1 166
DC1 167
DC1 168
DC1 169
DC1 170
DC1 171
DC1 172
DC1 173
DC1 174
DC1 175
DC1 176
DC1 177
DC1 178
DC1 179
DC1 180
DC1 181
DC1 182
DC1 183
DC1 184
DC1 185
DC1 186
DC1 187
DC1 188
DC1 189
DC1 190
DC1 191
DC1 192
DC1 193
DC1 194

DC1	195
DC1	196
DC1	197
DC1	198
DC1	199
DC1	200
DC1	201
DC1	202
DC1	203
DC1	204
DC1	205
DC1	206
DC1	207
DC1	208
DC1	209
DC1	210
DC1	211
DC1	212
DC1	213
DC1	214
DC1	215
DC1	216
DC1	217
DC1	218
DC1	219
DC1	220
DC1	221
DC1	222
DC1	223
DC1	224
DC1	225
DC1	226
DC1	227
DC1	228

```

C      JAL = J
      400 CONTINUE
      IA = JAL+1
      IB = JAL+2
      PUT IN GRAPHICAL LIMITS.
      RD2(IA) = 0.
      RD2(IB) = 15.
      HT2(IA) = 30.
      HT2(IB) = -15.
      DO 6 IJL =1,2

```

```

C      PRINTOUT DATA AND RESULTS IN GRAPHICAL AND TABULATED FORM
C      -----

```

```

C      MISS 18 LINES IN O/P.
      WRITE(3,232)
      WRITE(3,216)ID(1)
      IF(ID(9).EQ.1)WRITE(3,208)
      IF(ID(9).EQ.2)WRITE(3,209)
      IF(ID(9).EQ.3)WRITE(3,210)
      IF(ID(9).EQ.4)WRITE(3,211)
      IF(ID(10).EQ.1)WRITE(3,212)
      IF(ID(10).EQ.2)WRITE(3,213)
      IF(ID(11).EQ.1)WRITE(3,214)
      IF(ID(11).EQ.2)WRITE(3,215)
      WRITE(3,217)ID(6)
      WRITE(3,218)HDR
      IF(ID(8).EQ.1)WRITE(3,206)
      IF(ID(8).EQ.2)WRITE(3,207)
      WRITE(3,219)ID(7)
      WRITE(3,220)ID(14)
      WRITE(3,221)ID(5)
      IF(ID(2).EQ.1)WRITE(3,200)
      IF(ID(2).EQ.2)WRITE(3,201)

```

```

IF(ID(3).EQ.1)WRITE(3,202)
IF(ID(3).EQ.2)WRITE(3,203)
IF(ID(4).EQ.1)WRITE(3,204)
IF(ID(4).EQ.2)WRITE(3,205)
WRITE(3,222)SP
WRITE(3,223)ID(12)
WRITE(3,224)ID(16)
WRITE(3,227)STI
WRITE(3,228)SPI
WRITE(3,229)SDI
WRITE(3,231)ATM
WRITE(3,2002)
      C      PLOT PEBBLE POSITION. (RADIUS/HEIGHT)
CALL PLOT(RD2,HT2,IB,26,45)
WRITE(3,2003)
      C      PLOT RESULTANT VELOCITY / HEIGHT.
WRITE(3,2002)
CALL PLOT(V02,HT2,JAL,37,45)
WRITE(3,8)
      C      PLOT ANGULAR POSITION / RADIAL POSITION.
WRITE(3,407)
CALL PLOT(RD2,THET2,JAL,37,45)
WRITE(3,2003)
      C      PLOT RESULTANT VELOCITY / RADIUS.
WRITE(3,2004)
CALL PLOT(RD2,V02,JAL,37,45)
WRITE(3,8)
WRITE(3,405)
WRITE(3,11)
WRITE(3,5)(T1(J),BALT2(J),HT2(J),RD2(J),THET2(J),VA2(J),VR2(J),
1VL2(J),VC2(J),V02(J),J=1,JAL)
6 CONTINUE
GO TO 4
401 WRITE(3,402)

```

```

DC1 229
DC1 230
DC1 231
DC1 232
DC1 233
DC1 234
DC1 235
DC1 236
DC1 237
DC1 238
DC1 239
DC1 240
DC1 241
DC1 242
DC1 243
DC1 244
DC1 245
DC1 246
DC1 247
DC1 248
DC1 249
DC1 250
DC1 251
DC1 252
DC1 253
DC1 254
DC1 255
DC1 256
DC1 257
DC1 258
DC1 259
DC1 260
DC1 261
DC1 262

```

```

GO TO 4
83 WRITE(3,6900)
2 FORMAT('0',1X,'NUMBER OF POINTS PLOTTED = ',I3)
5 FORMAT(' ',10E12.3)
7 FORMAT('0',7X,I5,F10.5,5I10)
8 FORMAT(' ',13X,'RESULTANT PEBBLE VELOCITY (INCHES PER MINUTE)')
11 FORMAT('0')
50 FORMAT(2I1)
100 FORMAT(I3,4I1,I2,5I1,F4.1,I3,I6,I3,I6,I5)
101 FORMAT(6A4,1X,F3.0,1X,2A4,A1,1X,A3,1X,A4,A1,1X,A3,1X,A2,1X,A4,A3,
11X,2A4,1X,A4)
102 FORMAT(2(A4,A3,1X),2A4,1X,A4,A1,1X,A4,A3,1X,4A4,A2,1X,A4,A3)
200 FORMAT(' PEBBLE DIAMETER',20X,' = 1 INCH')
201 FORMAT(' PEBBLE DIAMETER',20X,' = 0.75 INCHES')
202 FORMAT(' PEBBLE SHAPE',23X,'IS SPHERICAL')
203 FORMAT(' PEBBLE SHAPE',23X,'IS ASPHERICAL')
204 FORMAT(' PEBBLE SPECIFIC GRAVITY',21X,' = 3.0')
205 FORMAT(' PEBBLE SPECIFIC GRAVITY',21X,' = 3.4')
206 FORMAT(' EXTRACTOR POSITION',17X,'IS HIGH')
207 FORMAT(' EXTRACTOR POSITION',17X,'IS LOW')
208 FORMAT(' BASE ANGLE',25X,' = 15 DEGREES')
209 FORMAT(' BASE ANGLE',25X,' = 25 DEGREES')
210 FORMAT(' BASE ANGLE',25X,' = 35 DEGREES')
211 FORMAT(' BASE ANGLE',25X,' = 45 DEGREES')
212 FORMAT(' BASE SHAPE',25X,'IS CONICAL')
213 FORMAT(' BASE SHAPE',25X,'IS HEXAGONAL')
214 FORMAT(' BASE SURFACE',23X,'IS SLOTTED')
215 FORMAT(' BASE SURFACE',23X,'IS SMOOTH')
216 FORMAT('0RUN NUMBER',25X,' = ',I3)
217 FORMAT(' PEBBLE BED HEIGHT',18X,' = ',I2,' INCHES')
218 FORMAT(' BED HEIGHT/DIAMETER RATIO',10X,' = ',F4.2)
219 FORMAT(' EXTRACTOR DIAMETER',17X,' = ',I1,' INCHES')
220 FORMAT(' RECIRCULATION RATE',17X,' = ',I3,' PEBBLES / MINUTE')
221 FORMAT(' PEBBLE DROP HEIGHT',17X,' = ',I1,' INCHES')

```

```

DC1 263
DC1 264
DC1 265
DC1 266
DC1 267
DC1 268
DC1 269
DC1 270
DC1 271
DC1 272
DC1 273
DC1 274
DC1 275
DC1 276
DC1 277
DC1 278
DC1 279
DC1 280
DC1 281
DC1 282
DC1 283
DC1 284
DC1 285
DC1 286
DC1 287
DC1 288
DC1 289
DC1 290
DC1 291
DC1 292
DC1 293
DC1 294
DC1 295
DC1 296

```

```

222 FORMAT(' PEBBLE SEEDING RADIUS',14X,' = ',F4.1,' INCHES')
223 FORMAT(' SOURCE STRENGTH',20X,' = ',I3,' MILLICURIES')
224 FORMAT(' BED INVENTORY',22X,' = ',I5,' PEBBLES')
227 FORMAT(' SEEDING INVENTORY NUMBER',11X,' = ',F5.2)
228 FORMAT(' EXIT INVENTORY NUMBER',14X,' = ',F5.2)
229 FORMAT(' TRANSIT NUMBER',21X,' = ',F5.2)
231 FORMAT(' TIME FOR PEBBLE TO TRANSIT BED',5X,' = ',F6.1,' MINUTES')
232 FORMAT('1',//////////,17X,'RUN INFORMATION')
402 FORMAT('1THIS RUN HAS MORE THAN 200000 PEBBLES.')
405 FORMAT('1TIME (MINS) - TIME (PEBS) - HEIGHT - RADIUS - ANGLE DC1
1 - AXIAL VEL - RADIAL VEL - ANG VEL - CIRC VEL - RESULTANT VELDC1
2')
407 FORMAT('1 ANGULAR POSITION (DEGREES).')
408 FORMAT('1')
1001 FORMAT(I1,I1,I1,1X,I6,1X,3(I3,1X),I1)
2002 FORMAT('1 PEBBLE BED HEIGHT (INCHES)')
2003 FORMAT(' ',13X,'PEBBLE BED RADIUS (INCHES)')
2004 FORMAT('1PEBBLE BED RADIUS (INCHES)')
6900 FORMAT('0',1X,'NO NUMERIC DATA ON TAPE.')
4 STOP
END
C
C END
C ---
C

```

```

DC1 297
DC1 298
DC1 299
DC1 300
DC1 301
DC1 302
DC1 303
DC1 304
DC1 305
DC1 306
DC1 307
DC1 308
DC1 309
DC1 310
DC1 311
DC1 312
DC1 313
DC1 314
DC1 315
DC1 316
DC1 317
DC1 318
DC1 319
DC1 320
DC1 321

```

```

C
C
C
C

```

APPENDIX F

TRANSFORMATION OF CO-ORDINATES FROM THE TRACKER SYSTEM (θ_1, θ_2, z)
TO THE CYLINDRICAL CO-ORDINATE SYSTEM (r, θ, z)

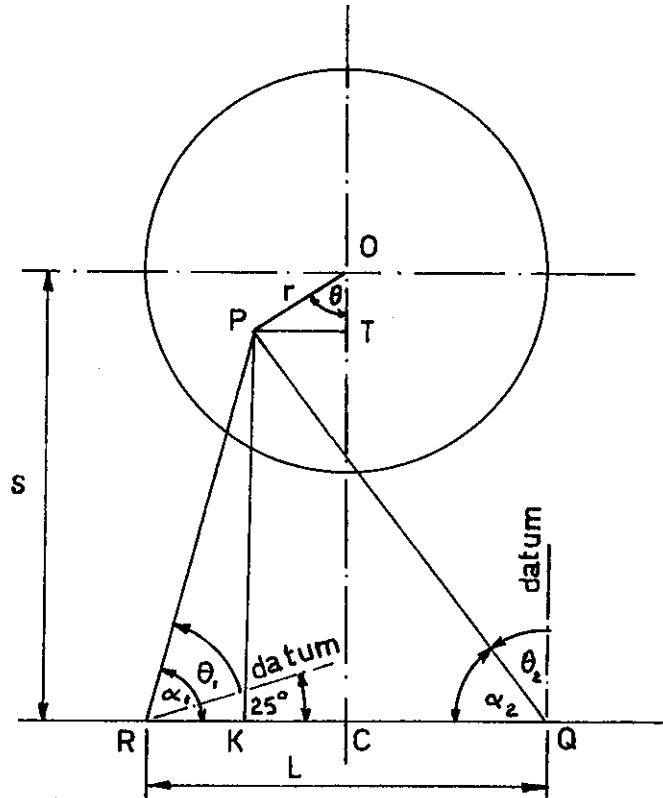

$$\alpha_1 = (\theta_1 + 25^\circ) \quad \alpha_2 = (90^\circ - \theta_2)$$

$$KP = RK \tan \alpha_1 \quad \dots (1)$$

$$KP = KQ \tan \alpha_2 \quad \dots (2)$$

$$RK + KQ = L \quad \dots (3)$$

From Equations (1) and (2)

$$RK \tan \alpha_1 = KQ \tan \alpha_2$$

or
$$\frac{KQ}{RK} = \frac{\tan \alpha_1}{\tan \alpha_2} \quad \dots (4)$$

Combining Equations (4) and (3)

$$\begin{aligned} \frac{\tan \alpha_1}{\tan \alpha_2} &= \frac{L - RK}{RK} \\ &= \frac{L}{RK} - 1 \end{aligned}$$

or
$$\frac{L}{RK} = \frac{\tan \alpha_1}{\tan \alpha_2} + 1$$

$$RK = \frac{L}{\frac{\tan \alpha_1}{\tan \alpha_2} + 1} = \frac{L \tan \alpha_2}{\tan \alpha_1 + \tan \alpha_2}$$

$$RK = \frac{L \tan \alpha_2}{\tan \alpha_1 + \tan \alpha_2} \quad \dots (5)$$

$$PT = \frac{L}{2} - RK$$

$$PT = L \left[\frac{1}{2} - \frac{\tan \alpha_2}{\tan \alpha_1 + \tan \alpha_2} \right] \quad \dots (6)$$

From Equation (1) viz

$$KP = RK \tan \alpha_1$$

we have by (5)

$$KP = \frac{L \tan \alpha_1 \tan \alpha_2}{\tan \alpha_1 + \tan \alpha_2} \quad \dots (7)$$

and thus OT is given by

$$OT = S - \frac{L \tan \alpha_1 \tan \alpha_2}{\tan \alpha_1 + \tan \alpha_2} \quad \dots (8)$$

r and θ now may be calculated using Equations (6) and (8)

$$r = \sqrt{OT^2 + PT^2}$$

for computational purposes it may be neater to evaluate OT and PT separately

$$r = \sqrt{\left[S - \frac{L \tan \alpha_1 \tan \alpha_2}{\tan \alpha_1 + \tan \alpha_2} \right]^2 + L^2 \left[\frac{1}{2} - \frac{\tan \alpha_2}{\tan \alpha_1 + \tan \alpha_2} \right]^2} \quad \dots (9)$$

Equation (9) may be rearranged

$$\frac{L \tan \alpha_1 \tan \alpha_2}{\tan \alpha_1 + \tan \alpha_2} = L \frac{\frac{\sin \alpha_1}{\cos \alpha_1} \frac{\sin \alpha_2}{\cos \alpha_2}}{\frac{\sin \alpha_1}{\cos \alpha_1} + \frac{\sin \alpha_2}{\cos \alpha_2}}$$

$$\frac{L \sin \alpha_1 \sin \alpha_2}{\sin \alpha_1 \cos \alpha_2 + \sin \alpha_2 \cos \alpha_1} = \frac{L \sin \alpha_1 \sin \alpha_2}{\sin (\alpha_1 + \alpha_2)}$$

$$\frac{\tan \alpha_2}{\tan \alpha_1 + \tan \alpha_2} = \frac{\frac{\sin \alpha_2}{\cos \alpha_2}}{\frac{\sin \alpha_1}{\cos \alpha_1} + \frac{\sin \alpha_2}{\cos \alpha_2}}$$

$$= \frac{\cos \alpha_1 \sin \alpha_2}{\sin \alpha_1 \cos \alpha_2 + \cos \alpha_1 \sin \alpha_2} = \frac{\cos \alpha_1 \sin \alpha_2}{\sin (\alpha_1 + \alpha_2)}$$

Therefore Equation (9) may be written

$$r = \sqrt{\left[S - \frac{L \sin \alpha_1 \sin \alpha_2}{\sin (\alpha_1 + \alpha_2)} \right]^2 + L^2 \left[\frac{1}{2} - \frac{\cos \alpha_1 \sin \alpha_2}{\sin (\alpha_1 + \alpha_2)} \right]^2} \quad \dots (10)$$

In terms of θ_1 and θ_2 , Equation (10) becomes

$$r = \sqrt{\left[S - \frac{L \sin (\theta_1 + 25^\circ) \sin (90^\circ - \theta_2)}{\sin (\theta_1 + 25^\circ + 90^\circ - \theta_2)} \right]^2 + L^2 \left[\frac{1}{2} - \frac{\cos (\theta_1 + 25^\circ) \sin (90^\circ - \theta_2)}{\sin (\theta_1 + 25^\circ + 90^\circ - \theta_2)} \right]^2}$$

$$= \sqrt{\left[S - \frac{L \sin (\theta_1 + 25^\circ) \cos \theta_2}{\cos (\theta_1 - \theta_2 + 25^\circ)} \right]^2 + L^2 \left[\frac{1}{2} - \frac{\cos (\theta_1 + 25^\circ) \cos \theta_2}{\cos (\theta_1 - \theta_2 + 25^\circ)} \right]^2}$$

$$PT = L \left[\frac{1}{2} - \frac{\cos (\theta_1 + 25^\circ) \cos \theta_2}{\cos (\theta_1 - \theta_2 + 25^\circ)} \right]$$

$$OT = S - \frac{L \sin (\theta_1 + 25^\circ) \cos \theta_2}{\cos (\theta_1 - \theta_2 + 25^\circ)}$$

$$\tan \theta = \frac{PT}{OT}$$

$$\theta = \tan^{-1} \frac{PT}{OT}$$

$$r = \sqrt{(OT)^2 + (PT)^2}$$

For computational purposes

$$r = \text{'RAD'} \quad \theta = \text{'THETA'}$$

$$\theta_1 = \text{'T3'} \quad \theta_2 = \text{'T4'}$$

$$L = 25.5 \text{ in.}, \quad S = 24.25 \text{ in.}$$

APPENDIX G

PEBBLE VELOCITIES CALCULATION

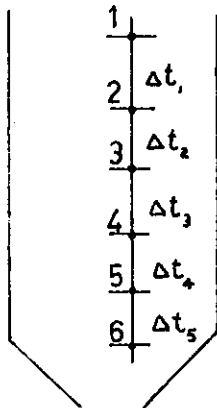

Assume that a pebble occupies positions 1, 2, 3, ... Then the average velocity between successive locations is given by

$$\bar{v} = \frac{\Delta S}{\Delta t}$$

The necessary assumption is that pebbles travel in straight lines between successive stations. Each station is characterised by its co-ordinates, r , θ , z .

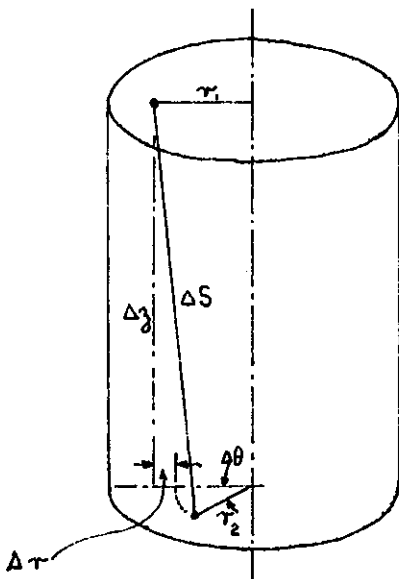

$$r_2 - r_1 = \Delta r$$

$$\theta_2 - \theta_1 = \Delta \theta$$

$$z_2 - z_1 = \Delta z$$

In orthogonal cartesian co-ordinates ΔS can be expressed as follows:

$$\Delta S = \sqrt{\Delta x^2 + \Delta y^2 + \Delta z^2}$$

Now, the relationship between cartesian and cylindrical co-ordinates is

$$z = z, x = r \cos \theta, y = r \sin \theta$$

Therefore

$$\begin{aligned}
 \Delta S &= \sqrt{(r_2 \cos \theta_2 - r_1 \cos \theta_1)^2 + (r_2 \sin \theta_2 - r_1 \sin \theta_1)^2 + (z_2 - z_1)^2} \\
 &= \sqrt{r_2^2 \cos^2 \theta_2 - 2 r_2 r_1 \cos \theta_2 \cos \theta_1 + r_1^2 \cos^2 \theta_1 + r_2^2 \sin^2 \theta_2 - \dots} \\
 &\quad \dots \\
 &\quad 2 r_2 r_1 \sin \theta_2 \sin \theta_1 + r_1^2 \sin^2 \theta_1 + (z_2 - z_1)^2} \\
 &= \sqrt{r_2^2 + r_1^2 - 2 r_2 r_1 (\cos \theta_1 \cos \theta_2 + \sin \theta_1 \sin \theta_2) + (z_2 - z_1)^2} \\
 &= \sqrt{r_2^2 + r_1^2 + (-2 r_2 r_1 + 2 r_2 r_1) - 2 r_2 r_1 \cos (\theta_2 - \theta_1) + (\Delta z)^2} \\
 &= \sqrt{(r_2 - r_1)^2 + 2 r_2 r_1 - 2 r_2 r_1 \cos (\theta_2 - \theta_1) + (z_2 - z_1)^2}
 \end{aligned}$$

i.e., finally

$$\Delta S = \sqrt{(r_2 - r_1)^2 + 2 r_2 r_1 (1 - \cos (\theta_2 - \theta_1)) + (z_2 - z_1)^2}$$

The velocity may now be calculated

$$\bar{v}_{1,2} = \frac{\sqrt{(r_2 - r_1)^2 + 2 r_2 r_1 (1 - \cos (\theta_2 - \theta_1)) + (z_2 - z_1)^2}}{\Delta t_{1,2}}$$

Velocity profiles are obtained from the above expression.

APPENDIX H
LIMITATIONS OF COMPUTER PLOTTING SUBROUTINE

There are limitations to the computer plotting subroutine used (Rodwell 1965). A point is plotted on the line corresponding to the value of the ordinate if the point falls on that line or up to half the distance between that line and the line on either side. Furthermore, if one point is being plotted in any one print position, it is represented by '.'. If more than one point is being plotted in the same print position, they are represented by the actual number of points in that position (up to nine). If more than nine points are being plotted in the same position, they are represented by '+'.

