



**AUSTRALIAN ATOMIC ENERGY COMMISSION  
RESEARCH ESTABLISHMENT  
LUCAS HEIGHTS**

**FLOW OF SPHERES AND NEAR-SPHERES IN CYLINDRICAL VESSELS  
PART III TRANSIT SPECTRA FOR RECIRCULATED RANDOM PACKINGS**

by

**F.C. GATT**

**March 1972**

ISBN 0 642 99460 9



AUSTRALIAN ATOMIC ENERGY COMMISSION

RESEARCH ESTABLISHMENT

LUCAS HEIGHTS

FLOW OF SPHERES AND NEAR-SPHERES IN CYLINDRICAL VESSELS

PART III

TRANSIT SPECTRA FOR RECIRCULATED RANDOM PACKINGS

by

F.C. GATT

ABSTRACT

The work presented is an experimental and statistical investigation of the transit number spectra (a particular transport characteristic) of identical pebbles in recirculated random packings in a cylindrical vessel with a base and a single central (axial) outlet. The packings form beds which flow downwards under the influence of gravity through an extractor in the vessel's base. The experimental variables studied are the base angle, the pebble seeding radius, the pebble size, shape and specific gravity, the packing height, the vessel base shape and the vertical position of the vessel's extractor. The purpose of the work was partly to study these variables for their effect on the amount of recirculation required for a particular pebble to emerge from the vessel and partly to obtain statistics on individual beds.

National Library of Australia card number and ISBN 0 642 99460 9

The following descriptors have been selected from the INIS Thesaurus to describe the subject content of this report for information retrieval purposes. For further details please refer to IAEA-INIS-12 (INIS: Manual for Indexing) and IAEA-INIS-13 (INIS: Thesaurus) published in Vienna by the International Atomic Energy Agency.

CONTAINERS; CYLINDRICAL CONFIGURATION; CYLINDERS; FUEL ASSEMBLIES;  
GEOMETRY; MOTION; PEBBLE BED REACTORS; RANDOMNESS; REACTOR CORES;  
REACTOR FUELING; SHAPE; SPHERES

## PREFACE

This report is part of a series on 'Flow of Spheres and Near-Spheres in Cylindrical Vessels' as follows:

- Part I - Experiments with recirculated random packings using flow visualisation technique. G.A. Tingate, A.A.E.C. report in preparation.
- Part II - Pebble transit in recirculated random packings. F.C. Gatt, AAEC/E207.
- Part III - Transit spectra for recirculated random packings. F.C. Gatt, AAEC/E<sub>1</sub> (this report)
- Part IV - Individual flow paths in recirculated random packings. F.C. Gatt, A.A.E.C. report in preparation.
- Part V - The effect of recirculation rate on pebble transit. M.E. Edwards, F.C. Gatt, G.A. Tingate, A.A.E.C. report in preparation.
- Part VI - Experiments with regular packings. G.A. Tingate, A.A.E.C. report in preparation.
- Part VII - Flow mechanisms in pebble beds. G.A. Tingate, A.A.E.C. report in preparation.
- Part VIII - Summary and conclusions. F.C. Gatt, G.A. Tingate, A.A.E.C. report in preparation.



CONTENTS

	<u>Page</u>
1. INTRODUCTION	1
2. EQUIPMENT	2
2.1 Pebbles	2
2.2 Vessel	2
2.3 Extractor	3
2.4 Pebble Packing	3
3. EXPERIMENTAL PROCEDURE	4
4. RESULTS	4
4.1 Transit Number Spectrum	4
4.2 Mean, Standard Deviation, Maximum, Minimum and Range of the Transit Number Spectrum	7
4.3 Reproducibility of Results and Similarity Testing	7
4.4 Testing of Effects on Transit Number	8
4.5 Pebble Bed Height for Minimum Transit Number Mean and Standard Deviation	10
4.6 Optimum Reactor Configuration	11
5. CONCLUSIONS	11
6. ACKNOWLEDGEMENTS	13
7. REFERENCES	13
APPENDIX 1	Nomenclature
APPENDIX 2	Subroutine HISTO
APPENDIX 3	Limitations of Computer Plotting Subroutine
APPENDIX 4	Subroutine MSD
APPENDIX 5	Coefficients and Constraints for Transit Number Expression
Table 1	Trial Specifications
Table 2	Spectral Types for Each Trial
Table 3	Frequency of Spectral Types for Each Seeding Radius
Table 4	Spectral Type Frequencies for each Base Angle
Table 5	Spectral Type Frequencies for each Base Shape

Contents (continued)

Table 6	Spectral Type Frequencies for each Extractor Position
Table 7	Spectral Type Frequencies for each Pebble Diameter
Table 8	Spectral Type Frequencies for each Pebble Shape
Table 9	Spectral Type Frequencies for each Pebble Specific Gravity
Table 10	Spectral Type Frequencies for each Pebble Bed Height
Table 11	Mean and Standard Deviation Values of Transit Number Spectra
Table 12	Range, Minimum and Maximum Values of Transit Number Spectra
Table 13	Duplicated Trials
Table 14	Results of Trial Comparisons Using Kolmogorov-Smirnov Test
Table 15	Results of Duplicated Trial Comparisons using Kolmogorov-Smirnov Test
Table 16	Trials with a Single Parameter Change
Table 17	Effect of Base Shape on Transit Number
Table 18	Effect of Pebble Bed Height
Figure 1	Extractor and Base
Figure 2	Fully Seeded Pebble Bed Before Recirculation
Figure 3	Pebble Seeding Jig
Figures 4 to 47	Transit Number Spectra at all Radii for all Trials
Figure 48	Transit Number Spectral Types
Figure 49	Assumed Pebble Paths in Wall Region and Flow Zones
Figure 50	Standard Deviation versus Mean Ratio for all Trials at 14.5 inch Seeding Radius
Figure 51	Transit Number Spectra for Trials 1, 2 and 9 at 6 inch Seeding Radius
Figure 52	Range of Transit Number Spectral Means for Varying Base Angle and Seeding Radius





## 1. INTRODUCTION

If a pebble is repeatedly seeded in a given part of a randomly packed recirculating bed of identical pebbles, the time spent by the pebble in passing through the vessel will vary. In this report the variation of the time spent is investigated in terms of the pebble transit number and the transit number distribution or spectrum. Here, the transit number,  $T$ , of the pebble is defined as the number of pebbles recirculated between the seeding of the pebble in the bed and its exit from the bed, expressed as a fraction of the bed inventory (the total number of pebbles in the bed),  $N$ . The complete nomenclature is listed in Appendix 1.

The transit number spectra may differ in many ways. In practice, the salient features of each may be represented by a small number of statistics - a measure of position, a measure of extendedness, a measure of symmetry, and a measure of peakedness (the degree to which the observations form a sharp mode as opposed to a flat one). The objectives of the work were:

(a) To determine the shape of the transit number spectrum for pebbles seeded at the top of a randomly packed bed of pebbles (symmetry and peakedness).

(b) To find the mean, standard deviation, maximum, minimum and range of each transit number spectrum (position and extendedness).

(c) To find the transit number spectra which were similar to better than 33.3 per cent, i.e. those spectra which could be accepted to be from the same parent population with a 33.3 per cent probability of being correct (Gatt, 1968).

(d) To find the effect on the transit number mean and standard deviation of changes in -

- (i) base angle
- (ii) base shape
- (iii) extractor position
- (iv) pebble diameter
- (v) pebble shape
- (vi) pebble specific gravity

- (vii) pebble bed height, and
- (viii) seeding radius.

Throughout this report the words 'standard deviation', unless otherwise noted, refer to the unbiased standard deviation value.

Experimental information on the position of the pebble as it passes through the pebble bed is given in Part IV of this report series.

## 2. EQUIPMENT

### 2.1 Pebbles

Four types of pebbles were press-formed from plastic bonded zircon sand, after which they were cured to the desired hardness and plastic coated to provide wear resistance. The finished pebbles had the following properties:

Surface finish (projections)	$\pm 0.001$ in.
Sphericity	$\pm 2$ per cent
Diameter	$1.00 \pm 0.02$ in. and $0.75 \pm 0.02$ in.
Specific gravity	$3.00 \pm 0.07$ $3.40 \pm 0.07$

The value of the nominal pebble diameter ( $D_p$ ) is used to specify the size of both spherical and aspherical pebbles.

In effect two sizes of aspherical pebble were produced by removing from each spherical pebble a slab of thickness  $0.10 D_p$  centred on the pebble equator, and then joining the identical halves. The resulting pebble had an equatorial diameter of  $0.999 D_p$  and a length through the poles of  $0.90 D_p$ . Sphericity of the segments and the dimensions were held to the above tolerances.

Pebbles intended for seeding were dipped into staining solutions of 'Maruzen Ink' for identification.

### 2.2 Vessel

The pebble vessel was an upright aluminium cylinder with diameter 30 in. and height 60 in. A cone, (Figure 1), and in some cases a hexagon - faceted cone, (concave as viewed from above), formed the base of the vessel. Throughout this report the different bases are henceforth

referred to as either a conical or hexagonal base. As pebbles were extracted one by one the bed flowed under its own weight down the vessel into the extractor located in the single axial outlet tube at the base. Pebbles leaving the extractor fell through a tube on to a sloping trough to be elevated to above the top of the bed by an endless bucket conveyor. They then rolled by gravity along a second trough to drop approximately 6 in. on to the centre of the bed surface. When passing along the first trough, they were counted automatically with a photoelectric counter and the marked pebbles were picked out manually while the number registering on the counter was noted.

### 2.3 Extractor

The extraction mechanism was situated at the vertex of the vessel base (high position), or in some cases 12 in. below the vertex of the vessel base (low position), in a single axial outlet tube (Figure 1). The extractor consisted of a raised cylindrical centre surrounded by a trough into which pebbles aligned themselves. The extractor rotated while the pebbles were held almost stationary by the weight of the pebble packing above. When an elongated hole located in the trough passed beneath a pebble, that particular pebble fell into the rotating pipe attached to the extractor and out of the vessel.

The extraction rate throughout the experiment was set at a nominal 350 pebbles per minute which was the fastest attainable extraction rate for the extractor used. The rate of extraction was checked at intervals throughout the experiment and was found to have a variation of  $\pm 50$  pebbles per minute. These variations in the recirculation rate had no noticeable effect on the transit number (Part II of this report series.)

### 2.4 Pebble Packing

The packing of identical pebbles was made up of the following sections as shown in Figure 2:

- (i) The base section.
- (ii) The cylindrical section, whose length at the start of recirculation is termed the pebble bed height (H).
- (iii) A top conical section of pebbles extending from the top of the cylindrical section to the apex of the cone formed when pebbles are dropped down the axial centre of the vessel onto the cylindrical section.

### 3. EXPERIMENTAL PROCEDURE

The pebble bed was filled with unmarked identical pebbles to the required bed height, H. Coloured similar pebbles were seeded (using the seeding jig shown in Figure 3) on the upper surface of this packing, that is, on the horizontal level H, and at radial distances of 3, 6, 9, 12 and 14.5 in. with each seeding radius having a different colour. The top cone of pebbles was formed manually over the seeded pebbles thereby simulating the mound of pebbles formed during recirculation. Recirculation of the bed was then started. The number of pebbles in transit between the extractor and re-insertion at the top of the bed did not exceed 400, which is negligible in comparison with a typical inventory of 30,000 pebbles. The transit number of each coloured pebble was noted at the moment of its extraction. With the pebbles seeded in circular arrays at various radii five transit number spectra were found (one at each radius) for each pebble type and bed and vessel configuration. The pebble and vessel geometry specifications for each trial are given in Table 1.

### 4. RESULTS

#### 4.1 Transit Number Spectrum

##### (a) General

The transit number data were arranged in histogram form. For this purpose, a general histogram subroutine was formulated in Fortran IV, (Appendix 2). The number of class intervals used to present the histograms was varied from 2 to 16. A clear picture could be obtained by grouping the data into 6 class intervals for each of the five seeding radii. The transit number spectra were then plotted with a computer using adapted versions of the histogram subroutine, and a plotting subroutine in Rodwell (1965). The limitations of this plotting technique are discussed in Appendix 3. The transit number spectra for all trials at each seeding radius are given in Figures 4 to 47. In the lower right hand corner of these figures the five spectra are combined for comparison but are too close to each other to be detailed separately. The spectra appear to be either one, or a combination of several of six different idealised types depicted in Figure 48.

##### (b) Characteristics of idealised spectra

In a test giving a type A spectrum (Figure 48(a)) the majority of seeded pebbles would emerge quickly, the rate of emergence tapering

rapidly at first then more slowly towards the exit of the last pebble. This behaviour indicates that a small number of pebbles could have entered the dead zone (Deutsch, 1967) in the lower corners of the vessel, (Figure 49) where little or no movement of the bed takes place. Those pebbles which pass through the dead zone would most probably have been seeded in or near the wall region of the pebble bed.

The reverse of type A behaviour is shown by type B (Figure 48(b)) where the majority of pebbles would emerge toward the end of the transit number spectrum, a possible indication of greater dead zone penetration.

Figure 48(c), type C, (the inverse of type B) shows that the rate of exit of seeded pebbles would be high and would then quickly reduce indicating that many pebbles could have traversed the bed via the pipe zone or another fast moving zone through the bed.

Type D (Figure 48(d)) is the reverse of type C and the inverse of type B. The pebble flow indications here would be similar to those of type B.

Type E in Figure 48(e) indicates that the frequency of seeded pebbles emerging from the vessel would be low at the start, increasing to a maximum and then decreasing at approximately the rate of increase. This type would probably approximate to a normal spectrum.

Type F, (bimodal shape), is shown in Figure 48(f). Here there would be two or more main streams of pebble flow. A portion of the seeded pebbles "x" would emerge quickly, probably by moving directly across to the fast flowing pipe zone and then down the vessel, while another almost equally large portion "y" would emerge after a short interval taking a longer route. This longer route could be either down the vessel wall in the case of the pebbles seeded at 14.5 in. radius, or down through the pipe feed zone in the case of the pebbles seeded closer in to the bed centre.

A measurement of the spectral shape is thus seen to impart some knowledge of the spread of pebbles emerging from the bed. Further it give information as to the proportion of pebbles taking the various available paths through the bed.

#### (c) Classification of spectra

Each of the 44 trials were labelled with the spectral type which corresponds most closely (by visual inspection) to the spectrum at each seeding radius given in Figures 4 to 47. The allocated types are listed

in Table 2. The table shows that the majority of the spectra are of either type E or type F. In the case of this form of random observation it would be expected that many spectra would be of the type E or normal spectrum and this is so.

Table 3 shows the frequency of spectral types at each seeding radius. The frequency is given as the percentage of all spectral types at each seeding position. It was expected that the bimodal or type F spectrum would predominate at the seeding positions in or near the wall region. However on inspection it is seen that the type F spectrum predominates in the bed centre seeding positions and becomes less frequent the further the seeding radius is increased (except in the wall region where the frequency rises to 41 per cent). Spectral type E has a low frequency in the bed centre seeding positions but it increases to a maximum in the 9 to 12 in. seeding positions and then decreases to become almost equal in frequency to the type F spectrum at the wall.

(d) Influence of individual parameters

This same effect is generally evident when the frequencies of the spectral types are investigated to ascertain any influence of individual bed and pebble parameters. For this purpose all trials are separated into their spectral types at each seeding radius for each vessel and pebble parameter (using Tables 1 and 2) and the frequencies are shown in Tables 4 to 10. The frequencies of spectral types A, B, C and D (Table 3) are much lower than types E and F and for this reason are not listed in the results. The occurrence of type E spectra is almost the complement of type F because of a small occurrence of the other spectral types.

(e) Possible explanation of predominance of type E and F spectra

The reason for the expected predominance in type F spectra in the wall region was the supposedly greater multiplicity of paths available to a pebble progressing toward the extractor from this region. A possible explanation (for this apparent slight difference) could be the relative difference in scale between the x axis in the 3 in. seeding radius case as against the 14.5 in. seeding radius case. The greater expectation of two paths of pebble flow (two maxima in the spectrum) in the case of the 14.5 in. seeding radius spectrum would be due to the greater difference in transit number between the two possible extreme pebble paths through the vessel. This difference would apparently be

greater than the difference between extreme paths in the case of the 3 in. spectrum, assuming that the longest path length in the 3 in. spectrum was approximately vertically down the vessel and not down the vessel wall. It can be concluded then that spectral types E and F are by far the most probable types of spectra for pebbles emerging from a randomly packed pebble bed after seeding in the same position.

#### 4.2 Mean, Standard Deviation, Maximum, Minimum and Range of the Transit Number Spectrum

The spectral parameters: mean, unbiased standard deviation, maximum and minimum were found using the subroutine MSD (Appendix 4). The trial range is equal to the maximum value less the minimum value. The mean and standard deviation values are listed for each trial in Table 11. The range, minimum and maximum values are listed in Table 12.

The mean and standard deviation values show that, in the vessel wall region (defined by a radius greater than 80 per cent of the vessel radius, i.e. 12 in.), both mean transit number and the spread of the transit number spectrum increase. This implies a greater probability of error in predicting pebble transit number values in this region.

A chart of the standard deviation versus mean ratio for all trials is shown in Figure 50. A measure of stratification of the trials according to their base angle can be seen.

#### 4.3 Reproducibility of Results and Similarity Testing

To test whether the transit number results were reproducible some trials were re-run using the same geometry, seeding conditions and pebbles. Each spectral mean was subtracted from the average of the spectral means and expressed as a percentage of the average. The maximum variation was 24 per cent, with three quarters of the variations within 4 per cent, showing good agreement. The 12 sets of duplicate trials are listed in Table 13. Trials 12 and 25 had the same geometry and seeding conditions, but bed inventory was different; for the above test these trials were not regarded as identical. Figure 51 shows the histograms of the duplicate trials 1, 2 and 9 at the 6 in. seeding radius.

A statistical comparison of trials was made using the Kolmogorov-Smirnov test (subroutines of which are given by Gatt 1968, and Anonymous 1968), each trial being tested against every other at the particular radius. These tests show similarity of the trials to a certain

percentage, that is the trials can be accepted to be from the same parent population with an 'x' per cent probability of being correct. Those trials found to have a percentage similarity better than 33.3 per cent are listed in Table 14. The figure of 33.3 per cent has no special significance here; it is an arbitrary limit set to show the small fraction of trial tests which are similar at this seemingly low similarity level. It also serves to emphasise the severity of the Kolmogorov-Smirnov test, since of the 12 sets of duplicate trials discussed above, only three showed similarity above 33.3 per cent. These are denoted with an asterisk in Table 14. The results of this type of testing on the 12 sets of duplicate trials are shown in Table 15. All these duplicate sets, except one, show some similarity for at least one of the seeding positions. This similarity testing is not to be compared with the testing of the mean values above. The mean value tests examine only the positions of the spectra whereas the Kolmogorov-Smirnov test examines the positions and shapes of the spectra and therefore requires a high degree of similarity to register.

#### 4.4 Testing of Effects on Transit Number

Apart from the case of the base angle parameter (the dominating parameter in the determination of transit number), the method used to detect the effects on transit number of changes in vessel and pebble properties was to compare trials which differed only in the level of the parameter being tested. A list of the trials used in this method is given in Table 16.

In the case of base angle changes, two methods were used to detect the effects on transit number. One method was the above and the other was to take all 44 trials and separate them into each level of base angle being tested for effect on transit number. The means and standard deviations in each level were thus compared as a whole against those of the other levels. This gave only a general indication of the gross effects of parameter change on transit number mean and standard deviation.

##### 4.4.1 Effect of base angle on transit number

Figure 52 shows the range of transit number spectral means for varying base angle and seeding radius. It is evident that the larger the base angle and the smaller the seeding radius, the smaller is the spread of the means.

The  $45^\circ$  base angle has the least change in transit number across the seeding radius and by visual extrapolation it appears that a near constant transit number (unity) would occur using a near  $60^\circ$  base angle.

Note that since continuity of flow has been established in the vessel it implies that there must be a seeding radius at which the transit number is unity and that integrated flow on either side of this radius must be equal. In this set of trials the radius of unity transit number occurs at approximately 12.5 inches for all base angles. This is an interesting observation but its significance is unknown. However in Figure 53, as the base angle increases, the transit number to the right of the unity transit number point decreases; then it follows that the transit number to the left of the unity transit number point must increase as base angle increases since the integrated transit number should be constant. The transit number is integrated with respect to the vessel radius (0 to 15 inches) and to the angle of revolution ( $0^\circ$  to  $360^\circ$ ) of the radius around the vessel central axis.

The effects on the standard deviation of the transit number spectrum of changes in base angle and seeding radius is shown in Figure 54. For the 3, 6 and 9 in. radial positions standard deviations are generally small, approximately 0.015 (transit number). However, the range of standard deviation and the absolute value of standard deviation generally increase as seeding radius increases and base angle decreases.

In the comparison of the means for the trials differing only in base angle, the effect was generally as shown in Figure 55. An increase in base angle leads to a large decrease in the mean value of the 14.5 inch transit number spectra and a slight increase in the mean value of the 3, 6, 9 and 12 in. transit number spectra. A similar situation exists for the comparison of the standard deviations of the transit number spectra (Figure 56).

#### 4.4.2 Effect on transit number of other parameters

Except as otherwise noted, all the following conclusions have been based upon the comparison of means and standard deviations for trials differing only in respect of the parameter investigated.

##### A. Vessel and bed characteristics

(a) Base shape. Tests were performed with a  $25^\circ$  base angle for two cases: conical and hexagonal bases. Spherical and aspherical pebbles of diameter 0.75 inches and specific gravity 3.4 were used.

Bed height was 30 inches in all tests. The extractor position (Figure 1) in all cases was high. The results in Table 17 show that with spherical pebbles for conical base shape the transit number mean is greater below 80 per cent radius and smaller above than with hexagonal base shapes indicating that a spherical pebble will give a flatter transit number spectrum with a conical base shape than with an hexagonal base shape. The spectra standard deviations were smaller the less the transit number mean, and larger the greater the transit number mean. However, with aspherical pebbles the converse is true, that is an hexagonal base shape will give a flatter transit number spectrum than a conical base shape.

(b) Extractor position. No variations in the extractor position were made, but the effect was considered negligible.

(c) Pebble bed height. No effect was detected for bed heights between 28 inches and 30 inches although these gave flatter spectra than at 24 inches. Some other effects were apparent in the case of the  $35^\circ$  base angle trials (see Section 4.5).

(d) Seeding radius. The spectra of trial number 18 ( $35^\circ$  cone) are plotted (Figure 57) to show the variation of the transit number spectra across the seeding radius. The larger the seeding radius, the larger was the magnitude of the transit number and the greater its scatter. The number of class intervals in each case was 6. The arithmetic mean, standard deviation and total number of observations at each seeding radius are given in Tables 1 and 11. In general the effect on transit number of increasing seeding radius is to increase both the mean and the standard deviation of the transit number spectrum as in Figure 57. There is little increase in both quantities from 3 in. to 9 in. radial seeding position, but at and beyond the 12 in. position both the mean and standard deviation increase rapidly (Figures 52 and 54).

#### B. Pebble characteristics

No significant effects were observed for changes in pebble diameter and pebble specific gravity. Only the effect mentioned in Section 4.4.2 A(a) was observed for a change in pebble shape.

#### 4.5 Pebble Bed Height for Minimum Transit Number Mean and Standard Deviation

The averages of transit number means and standard deviations were plotted against pebble bed height for  $35^\circ$  base angle trials (Table 18,

Figure 58). A minimum mean and standard deviation (minimum prediction error) at approximately 27.5 in. pebble bed height is evident for almost all radial seeding positions. The transit number (mean) curves could be quadratics dependent on pebble bed height together with an exponential dependent on seeding radius. Using a computer program (Sampson, undated) they were curve fitted with an expression of the form

$$T = a_1 + a_2H + a_3H^2 + a_4 \exp(a_5R)$$

The coefficients for the above expression appear in Appendix 5, together with the maximum percentage error between the actual and calculated transit numbers.

#### 4.6 Optimum Reactor Configuration

From the above data the following parameters should create optimum pebble flow conditions in a pebble bed nuclear reactor vessel. For equality of transit number across the bed and for least spread of transit number spectrum the optimum base angle would be  $45^\circ$  (Figures 52 and 54), or greater. Since spherical pebbles would most probably be used in a pebble bed reactor (aspherical pebbles being introduced into this work to simulate worn spherical pebble effects), then with a  $25^\circ$  base angle, the most favourable base shape to use would be conical (Table 17) and it is assumed that this would also be so for  $45^\circ$  base angle. Within the limits investigated the pebble diameter and specific gravity should have no effect. It may be preferable to use the low extractor position because of heat and nuclear radiation effects. The optimum pebble shape would be spherical and the optimum pebble bed height would be approximately 27.5 in. (Figure 58) with the above pebbles.

#### 5. CONCLUSIONS

Of the possible categories of spectra (Figure 48), the normal shape, type E, is the most common (55 per cent of total), the bimodal shape, type F, being the next most common (39 per cent of total). The remaining 9 per cent contains all the other shapes.

As seeding radius is increased from 3 to 12 in. the transit number mean and standard deviation are relatively unaffected; however, when the seeding radius is located in the vessel wall region (12 to 14.5 in.) the above spectral properties tend to increase sharply.

The parameter change producing the dominating effect on transit number was the vessel base angle which noticeably affected both mean and standard deviation of the transit number spectra. For larger base angles,

the velocity profile through the pebble bed is more horizontal and the transit number is more predictable.

The remaining vessel and pebble characteristics had a much smaller effect on the transit number spectra. However, when spherical pebbles are used in a vessel with an hexagonal base shape a much greater variation in both mean and standard deviation of the transit number spectra occurs across the vessel radius than in a vessel with a conical base and conversely, aspherical pebbles used with a conical base will give a much greater variation in the properties of the spectra than when used with an hexagonal base.

Pebble diameter and pebble specific gravity had no noticeable effect on the transit number spectra. However, the range of variation of these parameters is small and may not reasonably be expected to produce any significant effect on transit number.

It should be pointed out that whereas packings of identical pebbles produce very little difference when the diameter or specific gravity is changed within the above range, this probably would not occur if the pebbles were mixed. A mixture of 1.00 in. and 0.75 in. diameter pebbles would probably tend to segregate in the packing, resulting in a transit number spectrum of a completely different type.

Pebble bed height had an interesting effect in that for a  $35^\circ$  base angle, transit number spectra had a minimum mean and minimum standard deviation at 27.5 in. pebble bed height. Above and below this particular pebble bed height the mean and standard deviation tended to increase. This conclusion would suggest that using the  $35^\circ$  base angle, the pebble bed height for most reliable transit number prediction and for minimum pebble transit number through the bed, would be 27.5 in.

The Kolmogorov-Smirnov similarity testing of transit number spectra was not conclusive. Even under identical conditions of bed geometry and pebble properties it appears that the resulting transit number spectra are not sufficiently similar to register to any great extent with the test. This test is quite severe since it examines both the position and shape of the spectra. Examination of the mean transit numbers of the duplicated trials showed reasonable agreement as to the similarity in position if not the shape of the spectra.

The most important finding in relation to nuclear reactor design would be the need for a steep cone at the vessel base if flat transit

number spectra are to be achieved. The results could be applied fairly directly to the design of a very small reactor core, but care would have to be taken in extrapolating the results to large core sizes.

#### 6. ACKNOWLEDGEMENTS

The author thanks Mr. G.W.K. Ford, Mr. E. Szomanski and Mr. G. Tingate for comments and suggestions, Mrs. M.A. Cowper for computing and Mr. N. Hargreaves and Mr. R. Gumbleton for the experimental work.

#### 7. REFERENCES

- Anonymous, (1968) - Subroutine KOLM2, to Test the Difference between Two Sample Distribution Functions using the Kolmogorov-Smirnov Test - IBM Scientific Subroutine Package. IBM, Technical Publications Department, New York, U.S.A.
- Deutsch, G.P. (1967) - Investigation of Flow Mechanism of Balls in a Container - Departmental Report Number 14, Department of Civil Engineering, University of Melbourne.
- Gatt, F.C. (1968) - A Digital Computer Program for Applying the Kolmogorov-Smirnov Test of Similarity to Two Sample Populations. AAEC/TM504.
- Rodwell, J. (ed), (1965) - 7040 Subroutines Currently Available from Reactor Physics. AAEC-RP/CP47.
- Sampson, P. (undated) - BMDX 85, Non Linear Least Squares - Health Sciences Computing Facility, University of California, Los Angeles, California, 90024.



APPENDIX 1

NOMENCLATURE

$a_1$	}	coefficients for transit number expression
$a_2$		
$a_3$		
$a_4$		
$a_5$		
$D_p$		nominal pebble diameter
H		pebble bed height, the height of the cylindrical section of the pebble bed at the start of recirculation
N		bed inventory, defined as the total number of pebbles in the pebble bed
R		radius of the seeded pebble (at seeding) from the bed centreline (in.)
T		transit number of a particular pebble, defined as the number of pebbles recirculated between the seeding of the particular pebble and the exit of the particular pebble from the pebble bed, expressed as a fraction of the bed inventory N



APPENDIX 2

SUBROUTINE HISTO

C SUBROUTINE NAME : HISTO	HISTO 1
C PURPOSE : TO PLOT A HISTOGRAM OF A SET OF OBSERVATIONS.	HISTO 2
C METHOD OF SOLUTION : SEE REFERENCE	HISTO 3
C REFERENCE : LINDGREN BW & MCELRATH GW (1959), INTRODUCTION TO	HISTO 4
C PROBABILITY AND STATISTICS, MACMILLAN.	HISTO 5
C AUTHOR : GATT F.C.	HISTO 6
C SUBROUTINES USED : MSD	HISTO 7
C PLOT	HISTO 8
C COMPUTER : IBM 360/50	HISTO 9
C PROGRAM LANGUAGE : FORTRAN 4	HISTO 10
C ARGUMENTS :	HISTO 11
C RIN = OBSERVATION VECTOR.	HISTO 12
C NC = NUMBER OF OBSERVATIONS. (MAX=3000)	HISTO 13
C IN = NUMBER OF CLASS INTERVALS IN VECTOR. (MAX=3000)	HISTO 14
C HI=HISTOGRAM IDENTIFYING NUMBER.	HISTO 15
C IOP = WRITTEN OUTPUT OPTION	HISTO 16
C = 1 FOR HEADING, HISTOGRAM & WRITTEN COORDINATES.	HISTO 17
C = 2 FOR HEADING & HISTOGRAM.	HISTO 18
C = 3 FOR HEADING & WRITTEN COORDINATES.	HISTO 19
C IP = PUNCHED OUTPUT OPTION	HISTO 20
C = 1 FOR CARD PUNCHING OF HISTOGRAM COORDINATES.	HISTO 21
C = 2 FOR NC CARD PUNCHING.	HISTO 22
C NOMENCLATURE :	HISTO 23
C AMA = CLASS BOUNDARY.	HISTO 24
C FREQ = FREQUENCY IN EACH CLASS INTERVAL (EXCEPT FREQ(IN+1),	HISTO 25
C FOR GRAPH SIZING.)	HISTO 26
C AMPT = MIDPOINTS OF EACH CLASS INTERVAL, (EXCEPT AMPT(IN+1)	HISTO 27
C FOR GRAPH SIZING.)	HISTO 28
C X = INTERVAL LENGTH.	HISTO 29
C SUBROUTINE HISTO(RIN,NO,IN,HI,IOP,IP)	HISTO 30
C DIMENSION RIN(3000),AMA(3000),AMPT(3000),FREQ(3000)	HISTO 31
C FIND MAX AND MIN RIN VALUES.	HISTO 32
C CALL MSD(RIN,NC,AM,SD,Y1,Y2)	HISTO 33
C J1 = IN+1	HISTO 34
C AMA(J1) = Y1	HISTO 35
C AMA(1) = Y2	HISTO 36
C DIVIDE INTO IN CLASS INTERVALS.	HISTO 37
C XA = IN	HISTO 38
C X = (AMA(J1) -AMA(1))/XA	HISTO 39
C FIND CLASS BOUNDARIES.	HISTO 40
C DO 7 J=2,IN	HISTO 41
C 7 AMA(J) = AMA(1)+(X*(J-1))	HISTO 42
C FIND MIDPOINTS OF IN CLASS INTERVALS.	HISTO 43
C AMPT(1) = AMA(1)+X/2.	HISTO 44
C DO 4 L=2,IN	HISTO 45
C J6 = L-1	HISTO 46
C 4 AMPT(L) = AMPT(J6) +X	HISTO 47
C INITIALLY ZERO ALL FREQ.	HISTO 48
C DO 13 L=1,IN	HISTO 49
C 13 FREQ(L) = 0.	HISTO 50
C FIND FREQUENCY IN CLASS INTERVAL.	HISTO 51
C DO 6 J=1,IN	HISTO 52
C DO 6 K=1,NC	HISTO 53
C J7 = J+1	HISTO 54
C IF (J.FG.IN) GO TO 1	HISTO 55
C IF (RIN(K).GE.AMA(J).AND.RIN(K).LT.AMA(J7)) FREQ(J) =FREQ(J) +1.	HISTO 56
C GO TO 6	HISTO 57
C 1 IF (RIN(K).GE.AMA(J).AND.RIN(K).LE.AMA(J7)) FREQ(J) =FREQ(J) +1.	HISTO 58
C 6 CONTINUE	HISTO 59
C WRITE DATA AND PLOT GRAPH.	HISTO 60
C WRITE(3,12)	HISTO 61

APPENDIX 2 (CONTINUED)

WRITE(3,10)HI	HISTO 62
WRITE(3,2) AM	HISTO 63
WRITE(3,3) SD	HISTC 64
WRITE(3,8) Y1	HISTO 65
WRITE(3,9) Y2	HISTC 66
WRITE(3,14)NO	HISTO 67
WRITE(3,17)IA	HISTC 68
GO TO(22,22,28),IOP	HISTO 69
22 WRITE(3,5)	HISTO 70
WRITE(3,18)	HISTC 71
CALL PLCT(AMPT,FREQ,IN,40,30)	HISTO 72
WRITE(3,11)	HISTO 73
28 GO TO(27,20,27),IOP	HISTO 74
27 WRITE(3,18)	HISTO 75
WRITE(3,25)	HISTC 76
WRITE(3,26)	HISTO 77
WRITE(3,18)	HISTO 78
WRITE(3,19)(AMPT(I),FREQ(I),I=1,IN)	HISTO 79
20 CONTINUE	HISTO 80
PLACH OUTPLT & HISTOGRAM NUMBER ON EACH CARD.	HISTO 81
GO TO(30,31),IP	HISTO 82
30 WRITE(2,29)(AMPT(I),FREQ(I),HI,I=1,IN)	HISTC 83
31 CONTINUE	HISTO 84
2 FORMAT(' ',10X,'ARITHMETIC MEAN = ',E12.4)	HISTC 85
3 FORMAT(' ',10X,'STANDARD DEVIATION = ',E12.4)	HISTO 86
5 FORMAT('O*** FREQUENCY ***')	HISTO 87
8 FORMAT(' ',10X,'MAXIMUM VALUE = ',E12.4)	HISTO 88
9 FORMAT(' ',10X,'MINIMUM VALUE = ',E12.4)	HISTO 89
10 FORMAT(' ',17X,'HISTOGRAM NUMBER',F7.1)	HISTO 90
11 FORMAT('O',30X,'*** OBSERVATIONS ***')	HISTO 91
12 FORMAT('I')	HISTO 92
16 FORMAT(' ',10X,'NUMBER OF OBSERVATIONS = ',I8)	HISTO 93
17 FORMAT(' ',10X,'NUMBER OF CLASS INTERVALS = ',I8)	HISTO 94
18 FORMAT('C')	HISTC 95
19 FORMAT(' ',10X,2E16.4)	HISTO 96
25 FORMAT(' ',10X,'HISTOGRAM COORDINATES')	HISTO 97
26 FORMAT(' ',15X,'OBSERVATION FREQUENCY')	HISTO 98
29 FORMAT(2E16.4,F7.1)	HISTC 99
RETURN	HISTO100
END	HISTO101

### APPENDIX 3

#### LIMITATIONS OF COMPUTER PLOTTING SUBROUTINE

There are limitations of the computer plotting subroutine used (Rodwell, 1965). These are that a point is plotted on the line corresponding to the value on the ordinate if the point falls on that line or up to half the distance between that line and the line on either side. Further, if one point is being plotted in any one print position, it is represented by '\*'. If more than one point is being plotted in the same print position, they are represented by the actual number of points in that position (up to nine). If more than nine points are being plotted in the same position, they are represented by '+'.



APPENDIX 4

-----  
 SUBROUTINE MSD  
 -----

C SUBROUTINE NAME : MSD	MSD	1
C PURPOSE : TO CALCULATE THE MEAN, UNBIASED STANDARD DEVIATION, MAXIMUM AND MINIMUM OF A SET OF VALUES.	MSD	2
C METHOD OF SOLUTION : SEE REFERENCE	MSD	3
C REFERENCE : LINDGREN BW & MCEL RATH GW (1959), INTRODUCTION TO PROBABILITY AND STATISTICS, MACMILLAN.	MSD	4
C AUTHOR : GATT FC	MSD	5
C COMPUTER : IBM-360/50	MSD	6
C PROGRAM LANGUAGE : FORTRAN 4.	MSD	7
C ARGUMENTS : X = ARRAY NAME.	MSD	8
C I = NUMBER OF ELEMENTS IN X.	MSD	9
C AM = MEAN OF X.	MSD	10
C SD = UNBIASED STANDARD DEVIATION OF X.	MSD	11
C Y1 = MAXIMUM VALUE OF X.	MSD	12
C Y2 = MINIMUM VALUE OF X.	MSD	13
C RESTRICTIONS : MAXIMUM NUMBER OF ELEMENTS IN X IS 500.	MSD	14
SUBROUTINE MSD(X,I,AM,SD,Y1,Y2)	MSD	15
DIMENSION X(500)	MSD	16
C    CALCULATE MEAN OF X	MSD	17
SUM = 0.	MSD	18
DO 1 J = 1,I	MSD	19
1    SUM = SUM + X(J)	MSD	20
A = I	MSD	21
AM = SUM/A	MSD	22
C    CALCULATE UNBIASED STANDARD DEVIATION OF X.	MSD	23
SUM1 = 0.	MSD	24
DO 2 J = 1,I	MSD	25
2    SUM1 = SUM1 + X(J)**2	MSD	26
SD = SQRT(SUM1/(A-1.) - ((SUM**2)/(A*(A-1.))))	MSD	27
C    CALCULATE MAXIMUM AND MINIMUM VALUES OF X.	MSD	28
I1 = I+1	MSD	29
Y1 = X(I)	MSD	30
Y2 = X(I)	MSD	31
DO 3 I2=2,I	MSD	32
IF(X(I2).GT.Y1)Y1=X(I2)	MSD	33
3    IF(X(I2).LT.Y2)Y2=X(I2)	MSD	34
RETURN	MSD	35
END	MSD	36



APPENDIX 5

COEFFICIENTS AND CONSTRAINTS  
FOR TRANSIT NUMBER EXPRESSION

Transit number expression:

$$T = a_1 + a_2 H + a_3 H^2 + a_4 \exp(a_5 R)$$

Coefficients:

$$a_1 = + 8.6555$$

$$a_2 = - 0.59783$$

$$a_3 = + 0.011083$$

$$a_4 = + 0.010874$$

$$a_5 = + 0.2728$$

Constraints:

$$24 \leq H \leq 30 \text{ (inches)}$$

$$3 \leq R \leq 14.5 \text{ (inches)}$$

Maximum percentage error between actual and calculated transit numbers

$$= 16 \text{ per cent}$$

Maximum absolute error between actual and calculated transit numbers

$$= 0.17$$



TABLE 1

## TRIAL SPECIFICATIONS

TRIAL NO.	BASE ANGLE (DEG)	BASE SHAPE	EXTRACTOR POSITION	PEBBLE DIAM (IN.)	PEBBLE SHAPE	SPECIFIC GRAVITY	PEBBLE BED HEIGHT (IN.)	BED INVENTORY (PEBBLES)	NUMBER OF PEBBLES SEEDED AT RADII (IN.)				
									3	6	9	12	14.5
1	15	CCN	LCW	1.00	SPH	3.4	28	27540	17	36	56	78	91
2	15	CCN	LCW	1.00	SPH	3.4	28	27540	18	36	56	77	91
3	25	CCN	LCW	1.00	SPH	3.4	28	28310	17	33	54	78	91
4	25	CCN	LCW	1.00	SPH	3.4	28	28310	18	37	53	73	90
5	35	CCN	LCW	1.00	SPH	3.4	28	28754	18	36	56	78	91
6	35	CCN	LCW	1.00	SPH	3.4	28	28754	18	37	56	78	91
7	45	CCN	LCW	1.00	SPH	3.4	28	29900	18	37	56	75	91
8	45	CCN	LCW	1.00	SPH	3.4	28	29900	17	37	56	78	91
9	15	CCN	LCW	1.00	SPH	3.4	28	27540	18	37	56	75	91
10	35	CCN	HIGH	1.00	ASPH	3.4	30	35000	18	37	56	75	91
11	25	HEX	HIGH	0.75	ASPH	3.4	30	78000	25	49	75	100	118
12	25	CCN	HIGH	0.75	ASPH	3.4	30	82370	25	49	75	100	118
13	25	HEX	HIGH	0.75	SPH	3.4	30	67700	25	49	75	100	119
14	25	HEX	HIGH	0.75	SPH	3.4	30	67700	25	49	75	100	118
15	45	CCN	HIGH	0.75	SPH	3.4	30	71000	25	49	75	100	118
16	45	CCN	HIGH	0.75	SPH	3.4	28	67070	25	49	75	100	118
17	35	CCN	HIGH	0.75	SPH	3.4	30	69950	25	49	75	100	118
18	35	CCN	HIGH	0.75	SPH	3.4	30	69950	25	49	75	100	118
19	25	CCN	HIGH	0.75	SPH	3.4	30	67700	25	49	75	100	118
20	25	CCN	HIGH	0.75	SPH	3.4	30	67700	25	49	75	100	118
21	15	CCN	HIGH	0.75	SPH	3.4	30	66000	25	49	75	100	117
22	15	CCN	HIGH	0.75	SPH	3.4	30	66000	25	49	75	100	118
23	45	CCN	HIGH	0.75	ASPH	3.4	30	82500	25	49	75	100	118
24	35	CCN	HIGH	0.75	ASPH	3.4	30	80000	25	49	75	100	118
25	25	CCN	HIGH	0.75	ASPH	3.4	30	75000	25	49	75	100	116
26	25	CCN	LCW	1.00	SPH	3.4	24	26600	18	37	56	75	91
27	35	CCN	LCW	1.00	SPH	3.0	24	26000	18	37	56	75	91
28	35	CCN	LCW	1.00	ASPH	3.0	30	33800	18	37	56	75	91
29	35	CCN	LCW	1.00	ASPH	3.4	24	29570	18	37	56	75	91
30	45	CCN	HIGH	1.00	ASPH	3.4	30	37000	18	37	56	75	91
31	45	CCN	HIGH	1.00	ASPH	3.4	30	37000	18	37	56	75	91
32	35	CCN	LCW	1.00	SPH	3.0	30	30414	18	37	56	75	91
33	35	CCN	LCW	0.75	ASPH	3.4	24	68000	25	49	75	100	118
34	35	CCN	LCW	1.00	ASPH	3.0	24	29500	18	37	56	75	91
35	35	CCN	LCW	0.75	ASPH	3.0	30	82000	25	49	75	100	118
36	35	CCN	LCW	0.75	ASPH	3.0	24	68000	25	49	75	100	118
37	35	CCN	LCW	0.75	SPH	3.0	30	71360	25	49	75	100	118
38	35	CCN	LCW	0.75	SPH	3.0	24	58000	25	49	75	100	118
39	35	CCN	LCW	0.75	SPH	3.4	24	58500	25	49	75	100	118
40	25	CCN	HIGH	1.00	ASPH	3.4	30	34977	18	37	56	75	91
41	15	CCN	HIGH	1.00	ASPH	3.4	30	33000	18	37	56	75	90
42	35	CCN	HIGH	1.00	ASPH	3.4	30	35000	18	37	56	75	91
43	25	CCN	HIGH	1.00	ASPH	3.4	30	34977	18	37	56	75	91
44	15	CCN	HIGH	1.00	ASPH	3.4	30	33000	18	37	56	75	91

CCN = CONICAL BASE SHAPE  
 HEX = HEXAGONAL BASE SHAPE  
 SPH = SPHERICAL PEBBLE SHAPE  
 ASPH = ASPHERICAL PEBBLE SHAPE

TABLE 2

SPECTRAL TYPES FOR EACH TRIAL

TRIAL NUMBER	SEEDING RADIUS (IN.)					I	
	I	3	6	9	12		14.5
1	I	E	E	E	A	C	I
2	I	E	F	E	E	F	I
3	I	E	F	F	E	E	I
4	I	F	F	E	E	E	I
5	I	F	E	A	E	E	I
6	I	F	F	F	E	E	I
7	I	E	F	E	F	E	I
8	I	F	F	F	E	E	I
9	I	F	E	E	A	E	I
10	I	F	F	F	E	E	I
11	I	E	E	E	E	E	I
12	I	F	E	E	E	E	I
13	I	E	E	F	F	F	I
14	I	F	F	E	E	E	I
15	I	F	E	E	E	F	I
16	I	F	F	F	E	F	I
17	I	F	B	E	E	A	I
18	I	F	E	E	E	F	I
19	I	F	F	E	E	F	I
20	I	F	E	E	E	F	I
21	I	F	E	E	E	A	I
22	I	F	E	E	E	A	I
23	I	F	F	E	E	F	I
24	I	E	F	E	E	E	I
25	I	F	E	F	E	A	I
26	I	F	F	E	E	F	I
27	I	F	E	E	E	E	I
28	I	E	E	E	E	F	I
29	I	F	E	E	F	F	I
30	I	F	F	F	E	F	I
31	I	F	E	E	E	F	I
32	I	F	E	E	F	E	I
33	I	E	E	E	E	F	I
34	I	F	E	E	F	F	I
35	I	F	F	E	F	E	I
36	I	E	E	F	E	E	I
37	I	F	E	E	E	F	I
38	I	F	E	E	F	E	I
39	I	F	F	F	E	E	I
40	I	E	F	E	E	E	I
41	I	A	E	E	A	A	I
42	I	F	E	E	F	F	I
43	I	F	E	F	F	F	I
44	I	F	E	E	F	A	I

TABLE 3

\* FREQUENCY OF SPECTRAL TYPES FOR EACH SEEDING RADIUS

SPECTRAL TYPE	SPECTRAL SEEDING RADIUS (IN.)					
	3	6	9	12	14.5	
A	2	0	2	7	14	
B	0	2	0	0	0	
C	0	0	0	0	2	
D	0	0	0	0	0	
E	25	62	75	70	43	
F	73	36	23	23	41	

\* FREQUENCIES EXPRESSED AS THE PERCENTAGE OF ALL SPECTRAL TYPES AT EACH SEEDING RADIUS.

TABLE 4

SPECTRAL TYPE FREQUENCIES FOR EACH BASE ANGLE

BASE ANGLE (DEG)	SPECTRAL TYPE E						SPECTRAL TYPE F					
	SEEDING RADIUS (IN.)						SEEDING RADIUS (IN.)					
	3	6	9	12	14.5		3	6	9	12	14.5	
15	5	14	16	7	2	9	2	0	2	2		
25	9	14	16	20	14	16	11	9	4	9		
35	9	27	32	30	23	34	14	9	14	18		
45	2	7	11	14	5	14	9	5	2	11		

THE TABULATED VALUES ARE THE FREQUENCIES OF OCCURRENCE OF TYPE E AND TYPE F SPECTRA, THE FREQUENCIES BEING EXPRESSED AS THE PERCENTAGE OF SPECTRAL TYPES AT EACH SEEDING POSITION.

TABLE 5

SPECTRAL TYPE FREQUENCIES FOR EACH BASE SHAPE

BASE SHAPE	SPECTRAL TYPE E						SPECTRAL TYPE F					
	SEEDING RADIUS (IN.)						SEEDING RADIUS (IN.)					
	3	6	9	12	14.5	3	6	9	12	14.5		
CENTRAL	20	57	71	66	39	71	34	20	20	35		
HEXAGONAL	5	5	5	5	4	2	2	2	2	2		

THE TABULATED VALUES ARE THE FREQUENCIES OF OCCURRENCE OF TYPE E AND TYPE F SPECTRA, THE FREQUENCIES BEING EXPRESSED AS THE PERCENTAGE OF SPECTRAL TYPES AT EACH SEEDING POSITION.

TABLE 6

SPECTRAL TYPE FREQUENCIES FOR EACH EXTRACTOR POSITION

EXTRACTOR POSITION	SPECTRAL TYPE E						SPECTRAL TYPE F					
	SEEDING RADIUS (IN.)						SEEDING RADIUS (IN.)					
	3	6	9	12	14.5	3	6	9	12	14.5		
HIGH	9	32	41	41	14	41	18	11	9	25		
LOW	16	30	34	20	29	32	18	11	14	16		

THE TABULATED VALUES ARE THE FREQUENCIES OF OCCURRENCE OF TYPE E AND TYPE F SPECTRA, THE FREQUENCIES BEING EXPRESSED AS THE PERCENTAGE OF SPECTRAL TYPES AT EACH SEEDING POSITION.

TABLE 7

SPECTRAL TYPE FREQUENCIES FOR EACH PEBBLE DIAMETER

PEBBLE DIAMETER (IN.)	SPECTRAL TYPE E						SPECTRAL TYPE F					
	SEEDING RADIUS (IN.)						SEEDING RADIUS (IN.)					
	3	6	9	12	14.5	3	6	9	12	14.5		
1.00	14	32	36	29	25	36	20	14	16	20		
0.75	12	30	39	41	18	36	16	9	7	20		

THE TABULATED VALUES ARE THE FREQUENCIES OF OCCURRENCE OF TYPE E AND TYPE F SPECTRA, THE FREQUENCIES BEING EXPRESSED AS THE PERCENTAGE OF SPECTRAL TYPES AT EACH SEEDING POSITION.

TABLE 8

SPECTRAL TYPE FREQUENCIES FOR EACH PEBBLE SHAPE

PEBBLE SHAPE	SPECTRAL TYPE E					SPECTRAL TYPE F				
	SEEDING RADIUS (IN.)					SEEDING RADIUS (IN.)				
	3	6	9	12	14.5	3	6	9	12	14.5
SPHERICAL	11	32	44	43	28	46	23	11	9	20
ASPHERICAL	14	30	32	27	16	27	13	11	14	20

THE TABULATED VALUES ARE THE FREQUENCIES OF OCCURRENCE OF TYPE E AND TYPE F SPECTRA, THE FREQUENCIES BEING EXPRESSED AS THE PERCENTAGE OF SPECTRAL TYPES AT EACH SEEDING POSITION.

TABLE 9

SPECTRAL TYPE FREQUENCIES FOR EACH PEBBLE SPECIFIC GRAVITY

PEBBLE SPECIFIC GRAVITY	SPECTRAL TYPE E					SPECTRAL TYPE F				
	SEEDING RADIUS (IN.)					SEEDING RADIUS (IN.)				
	3	6	9	12	14.5	3	6	9	12	14.5
3.0	5	16	16	9	11	14	2	2	9	7
3.4	20	46	59	61	32	59	34	21	14	34

THE TABULATED VALUES ARE THE FREQUENCIES OF OCCURRENCE OF TYPE E AND TYPE F SPECTRA, THE FREQUENCIES BEING EXPRESSED AS THE PERCENTAGE OF SPECTRAL TYPES AT EACH SEEDING POSITION.

TABLE 10

SPECTRAL TYPE FREQUENCIES FOR EACH PEBBLE BED HEIGHT

PEBBLE BED HEIGHT (IN.)	SPECTRAL TYPE E					SPECTRAL TYPE F				
	SEEDING RADIUS (IN.)					SEEDING RADIUS (IN.)				
	3	6	9	12	14.5	3	6	9	12	14.5
24	5	14	14	9	9	14	4	4	9	9
28	9	9	14	16	16	14	14	7	2	5
30	11	35	48	46	18	45	18	11	11	27

TABLE 11

\*  
 MEAN AND STANDARD DEVIATION  
 VALUES OF TRANSIT NUMBER SPECTRA

TRIAL NUMBER	SEEDING RADIUS (IN.)					
	3	6	9	12	14.5	
1	0.47 (0.015)	0.51 (0.013)	0.60 (0.027)	0.89 (0.173)	3.00 (1.319)	
2	0.46 (0.009)	0.49 (0.012)	0.58 (0.031)	0.93 (0.125)	3.16 (1.161)	
3	0.64 (0.016)	0.67 (0.018)	0.74 (0.018)	0.92 (0.055)	1.35 (0.141)	
4	0.58 (0.010)	0.62 (0.015)	0.71 (0.025)	0.90 (0.044)	1.37 (0.128)	
5	0.70 (0.011)	0.72 (0.010)	0.77 (0.030)	0.87 (0.032)	1.03 (0.055)	
6	0.70 (0.013)	0.72 (0.013)	0.77 (0.015)	0.86 (0.027)	1.03 (0.051)	
7	0.77 (0.017)	0.78 (0.013)	0.81 (0.015)	0.88 (0.024)	1.00 (0.044)	
8	0.72 (0.010)	0.73 (0.013)	0.76 (0.014)	0.83 (0.020)	0.96 (0.040)	
9	0.47 (0.011)	0.50 (0.014)	0.61 (0.024)	1.01 (0.190)	4.86 (1.705)	
10	0.72 (0.009)	0.73 (0.009)	0.79 (0.018)	0.92 (0.032)	1.26 (0.108)	
11	0.61 (0.010)	0.64 (0.010)	0.73 (0.021)	0.95 (0.052)	1.95 (0.427)	
12	0.57 (0.007)	0.61 (0.011)	0.67 (0.021)	0.87 (0.049)	2.43 (0.764)	
13	0.51 (0.013)	0.56 (0.011)	0.67 (0.014)	0.91 (0.057)	1.99 (0.526)	
14	0.48 (0.008)	0.52 (0.010)	0.64 (0.029)	0.88 (0.075)	2.37 (0.816)	

TABLE 11 (CONTINUED)

15	I	0.79	C.80	0.34	0.93	1.12	I
	I	(0.009)	(C.011)	(0.014)	(0.020)	(0.072)	I
	I						I
16	I	0.78	C.79	0.34	0.91	1.10	I
	I	(0.011)	(C.010)	(0.017)	(0.022)	(0.077)	I
	I						I
17	I	0.75	C.77	0.34	0.95	1.25	I
	I	(0.013)	(C.013)	(0.022)	(0.025)	(0.194)	I
	I						I
18	I	0.71	C.75	0.31	0.92	1.17	I
	I	(0.011)	(0.015)	(0.017)	(0.025)	(0.088)	I
	I						I
19	I	0.61	C.65	0.75	0.96	1.58	I
	I	(0.010)	(0.015)	(0.029)	(0.090)	(0.285)	I
	I						I
20	I	0.64	C.69	0.79	0.98	1.58	I
	I	(0.010)	(C.013)	(0.024)	(0.057)	(0.195)	I
	I						I
21	I	0.35	C.37	0.47	0.71	3.46	I
	I	(0.003)	(C.010)	(0.018)	(0.074)	(2.403)	I
	I						I
22	I	0.48	C.52	0.61	0.85	3.46	I
	I	(0.007)	(C.012)	(0.020)	(0.069)	(2.743)	I
	I						I
23	I	0.86	C.88	0.32	1.00	1.17	I
	I	(0.008)	(0.012)	(0.018)	(0.019)	(0.037)	I
	I						I
24	I	0.79	C.82	0.37	0.97	1.22	I
	I	(0.008)	(C.010)	(0.019)	(0.024)	(0.052)	I
	I						I
25	I	0.49	C.52	0.63	0.90	3.17	I
	I	(0.009)	(C.014)	(0.026)	(0.066)	(1.956)	I
	I						I
26	I	0.63	C.72	0.91	0.97	1.26	I
	I	(0.017)	(C.019)	(0.017)	(0.037)	(0.076)	I
	I						I
27	I	0.61	C.64	0.75	0.95	1.41	I
	I	(0.015)	(C.014)	(0.019)	(0.051)	(0.116)	I
	I						I
28	I	0.71	C.77	0.37	1.03	1.37	I
	I	(0.020)	(C.018)	(0.016)	(0.036)	(0.094)	I
	I						I
29	I	0.68	C.73	0.82	1.00	1.30	I
	I	(0.011)	(C.012)	(0.017)	(0.046)	(0.063)	I
	I						I
30	I	0.77	C.78	0.33	0.92	1.16	I
	I	(0.010)	(0.012)	(0.017)	(0.028)	(0.096)	I
	I						I
31	I	0.79	C.80	0.84	0.93	1.18	I
	I	(0.010)	(0.010)	(0.013)	(0.021)	(0.094)	I
	I						I
32	I	0.73	C.77	0.83	0.96	1.18	I
	I	(0.012)	(C.016)	(0.015)	(0.024)	(0.053)	I
	I						I
33	I	0.50	C.62	0.76	1.08	1.66	I
	I	(0.011)	(C.016)	(0.024)	(0.061)	(0.221)	I

TABLE 11 (CONTINUED)

34	I	0.51	C.57	0.71	0.93	1.50	I
	I	(0.010)	(0.015)	(0.029)	(0.059)	(0.111)	I
	I						I
35	I	0.74	C.78	0.86	0.99	1.27	I
	I	(0.005)	(0.009)	(0.015)	(0.028)	(0.083)	I
	I						I
36	I	0.57	C.62	0.80	1.09	1.65	I
	I	(0.007)	(0.018)	(0.070)	(0.060)	(0.126)	I
	I						I
37	I	0.78	C.81	0.87	0.97	1.13	I
	I	(0.009)	(0.012)	(0.014)	(0.027)	(0.041)	I
	I						I
38	I	0.70	C.74	0.84	1.00	1.30	I
	I	(0.010)	(0.014)	(0.016)	(0.036)	(0.067)	I
	I						I
39	I	0.65	C.71	0.82	1.00	1.32	I
	I	(0.015)	(0.016)	(0.025)	(0.040)	(0.113)	I
	I						I
40	I	0.43	C.46	0.54	0.83	3.35	I
	I	(0.006)	(0.010)	(0.020)	(0.108)	(1.499)	I
	I						I
41	I	0.42	C.45	0.52	0.85	4.46	I
	I	(0.007)	(0.007)	(0.019)	(0.122)	(3.582)	I
	I						I
42	I	0.70	C.71	0.77	0.90	1.24	I
	I	(0.012)	(0.012)	(0.012)	(0.031)	(0.115)	I
	I						I
43	I	0.52	C.54	0.61	0.81	2.07	I
	I	(0.010)	(0.010)	(0.015)	(0.052)	(0.490)	I
	I						I
44	I	0.44	C.48	0.57	0.87	4.03	I
	I	(0.012)	(0.016)	(0.019)	(0.105)	(2.601)	I
	I						I

\* VALUES OF STANDARD DEVIATION ARE IN BRACKETS.

TABLE 12

-----  
 RANGE, MINIMUM AND MAXIMUM  
 -----  
 VALUES OF TRANSIT NUMBER SPECTRA  
 -----

TRIAL NUMBER	SEEDING RADIUS (IN.)					I	
	I	3	6	9	12		14.5
1	I	0.06	0.06	0.17	1.11	5.66	I
	I	0.45-0.51	0.43-0.53	0.55-0.73	0.71-1.82	1.17- 6.83	I
2	I	0.04	0.05	0.15	0.70	4.50	I
	I	0.44-0.47	0.47-0.52	0.51-0.66	0.73-1.43	1.14- 5.64	I
3	I	0.06	0.10	0.08	0.33	0.63	I
	I	0.62-0.67	0.61-0.71	0.70-0.78	0.73-1.07	1.01- 1.64	I
4	I	0.03	0.06	0.12	0.19	0.64	I
	I	0.57-0.60	0.59-0.65	0.65-0.77	0.82-1.01	1.00- 1.64	I
5	I	0.04	0.04	0.23	0.15	0.27	I
	I	0.67-0.72	0.70-0.74	0.73-0.97	0.80-0.95	0.92- 1.20	I
6	I	0.04	0.05	0.06	0.11	0.20	I
	I	0.67-0.71	0.70-0.75	0.74-0.80	0.81-0.93	0.93- 1.13	I
7	I	0.06	0.07	0.07	0.10	0.18	I
	I	0.75-0.81	0.76-0.82	0.79-0.86	0.84-0.94	0.90- 1.08	I
8	I	0.03	0.06	0.06	0.09	0.20	I
	I	0.71-0.74	0.70-0.76	0.73-0.79	0.80-0.89	0.87- 1.07	I
9	I	0.03	0.05	0.10	1.21	6.48	I
	I	0.45-0.48	0.48-0.53	0.57-0.67	0.76-1.97	1.54- 8.02	I
10	I	0.04	0.03	0.07	0.14	0.53	I
	I	0.70-0.74	0.71-0.74	0.75-0.82	0.86-1.00	1.00- 1.53	I
11	I	0.04	0.05	0.09	0.22	2.08	I
	I	0.59-0.63	0.62-0.67	0.63-0.78	0.85-1.07	1.12- 3.21	I
12	I	0.03	0.05	0.09	0.23	3.12	I
	I	0.56-0.58	0.58-0.63	0.63-0.72	0.77-1.00	1.17- 4.29	I
13	I	0.05	0.06	0.08	0.28	2.11	I
	I	0.49-0.54	0.52-0.58	0.63-0.71	0.81-1.09	1.07- 3.18	I
14	I	0.04	0.04	0.15	0.66	3.49	I
	I	0.46-0.50	0.50-0.54	0.57-0.72	0.73-1.39	1.13- 4.61	I

TABLE 12 (CONTINUED)

15	I	0.03	0.05	0.06	0.12	0.31	I
	I	0.77-0.89	0.73-0.82	0.82-0.88	0.89-1.01	0.98-1.29	I
	I						I
16	I	0.05	0.06	0.11	0.11	0.37	I
	I	0.74-0.79	0.75-0.81	0.81-0.91	0.86-0.97	0.95-1.32	I
	I						I
17	I	0.04	0.06	0.17	0.14	1.38	I
	I	0.73-0.77	0.73-0.79	0.70-0.88	0.90-1.04	1.07-2.45	I
	I						I
18	I	0.04	0.06	0.08	0.13	0.35	I
	I	0.69-0.73	0.72-0.76	0.77-0.85	0.87-0.99	1.00-1.35	I
	I						I
19	I	0.04	0.06	0.11	0.36	1.18	I
	I	0.60-0.63	0.63-0.68	0.70-0.80	0.80-1.16	0.91-2.09	I
	I						I
20	I	0.04	0.08	0.11	0.31	0.90	I
	I	0.62-0.66	0.66-0.74	0.74-0.85	0.89-1.21	1.19-2.09	I
	I						I
21	I	0.01	0.04	0.08	0.37	11.94	I
	I	0.34-0.36	0.35-0.39	0.42-0.51	0.59-0.96	1.11-13.05	I
	I						I
22	I	0.02	0.06	0.09	0.54	13.84	I
	I	0.47-0.50	0.49-0.54	0.57-0.66	0.72-1.06	1.09-14.93	I
	I						I
23	I	0.03	0.04	0.09	0.08	0.15	I
	I	0.85-0.88	0.85-0.90	0.87-0.96	0.96-1.04	1.07-1.22	I
	I						I
24	I	0.04	0.04	0.07	0.11	0.22	I
	I	0.77-0.81	0.79-0.84	0.82-0.90	0.91-1.02	1.10-1.32	I
	I						I
25	I	0.03	0.06	0.10	0.42	10.63	I
	I	0.47-0.50	0.50-0.55	0.57-0.68	0.64-1.05	1.30-11.93	I
	I						I
26	I	0.06	0.07	0.07	0.16	0.34	I
	I	0.66-0.72	0.69-0.76	0.73-0.85	0.90-1.06	1.07-1.41	I
	I						I
27	I	0.05	0.06	0.09	0.28	0.53	I
	I	0.59-0.64	0.62-0.68	0.71-0.80	0.87-1.14	1.15-1.73	I
	I						I
28	I	0.08	0.08	0.07	0.14	0.35	I
	I	0.67-0.76	0.74-0.82	0.83-0.90	0.96-1.11	1.19-1.54	I
	I						I
29	I	0.04	0.06	0.07	0.21	0.28	I
	I	0.66-0.70	0.70-0.76	0.79-0.86	0.91-1.12	1.16-1.44	I
	I						I
30	I	0.03	0.05	0.07	0.14	0.37	I
	I	0.75-0.79	0.76-0.81	0.79-0.86	0.86-1.00	0.97-1.34	I
	I						I
31	I	0.04	0.04	0.07	0.10	0.35	I
	I	0.77-0.81	0.78-0.82	0.81-0.88	0.89-0.99	1.01-1.36	I
	I						I
32	I	0.04	0.08	0.07	0.10	0.26	I
	I	0.71-0.75	0.73-0.82	0.81-0.87	0.91-1.01	1.07-1.33	I
	I						I
33	I	0.05	0.07	0.11	0.26	0.82	I
	I	0.54-0.59	0.53-0.66	0.70-0.81	0.96-1.22	1.27-2.09	I

TABLE 12 (CONTINUED)

34	I I	0.04 0.49-0.53	0.06 0.55-0.61	0.13 0.64-0.77	0.30 0.85-1.15	0.52 1.17- 1.69	I I
35	I I	0.02 0.73-0.75	0.04 0.76-0.81	0.07 0.83-0.90	0.13 0.93-1.06	0.39 1.06- 1.45	I I
36	I I	0.03 0.55-0.59	0.03 0.53-0.66	0.33 0.70-1.03	0.26 0.98-1.25	0.53 1.37- 1.90	I I
37	I I	0.04 0.77-0.81	0.05 0.79-0.84	0.06 0.84-0.90	0.13 0.92-1.05	0.18 1.03- 1.26	I I
38	I I	0.04 0.68-0.71	0.06 0.71-0.78	0.07 0.81-0.88	0.17 0.92-1.10	0.31 1.14- 1.45	I I
39	I I	0.06 0.63-0.68	0.07 0.67-0.74	0.13 0.73-0.86	0.19 0.93-1.12	0.49 1.13- 1.63	I I
40	I I	0.02 0.42-0.44	0.04 0.44-0.48	0.09 0.49-0.59	0.61 0.65-1.25	7.37 0.74- 8.11	I I
41	I I	0.02 0.41-0.43	0.03 0.43-0.46	0.12 0.47-0.59	0.69 0.68-1.37	19.75 1.15-20.91	I I
42	I I	0.05 0.67-0.72	0.05 0.69-0.74	0.06 0.74-0.79	0.12 0.85-0.96	0.41 1.05- 1.45	I I
43	I I	0.04 0.50-0.54	0.05 0.52-0.56	0.07 0.57-0.64	0.25 0.72-0.97	1.95 1.29- 3.24	I I
44	I I	0.04 0.42-0.46	0.06 0.44-0.50	0.08 0.53-0.61	0.49 0.73-1.22	12.82 1.47-14.30	I I

---

TABLE 13

## DUPLICATED TRIALS

TRIAL NO.	BASE		EXTRACTOR POSITION		PEBBLE DIAM (IN.)	PEBBLE SHAPE	SPECIFIC GRAVITY	PEBBLE BED HEIGHT (IN.)	BED INVENTORY (PEBBLES)	NUMBER OF PEBBLES SEEDED AT RADII (IN.)				
	ANGLE (DEG)	SHAPE								3	6	9	12	14.5
1	15	CCN	LCW		1.00	SPH	3.4	28	27540	17	36	56	78	91
2	15	CCN	LCW		1.00	SPH	3.4	28	27540	18	36	56	77	91
3	15	CCN	LCW		1.00	SPH	3.4	28	27540	18	37	56	75	91
4	25	CCN	LCW		1.00	SPH	3.4	28	28310	17	33	54	78	91
5	25	CCN	LCW		1.00	SPH	3.4	28	28310	18	37	53	74	90
6	25	CCN	LCW		1.00	SPH	3.4	28	28754	18	36	56	78	91
7	25	CCN	LCW		1.00	SPH	3.4	28	28754	18	37	56	78	91
8	45	CCN	LCW		1.00	SPH	3.4	28	29900	18	37	56	75	91
9	45	CCN	LCW		1.00	SPH	3.4	28	29900	17	37	56	78	91
10	25	CCN	HIGH		1.00	ASPH	3.4	30	35000	18	37	56	75	91
11	25	CCN	HIGH		1.00	ASPH	3.4	30	35000	18	37	56	75	91
12	25	HEX	HIGH		0.75	SPH	3.4	30	67700	25	49	75	100	119
13	25	HEX	HIGH		0.75	SPH	3.4	30	67700	25	49	75	100	118
14	25	CCN	HIGH		0.75	SPH	3.4	30	69950	25	49	75	100	118
15	25	CCN	HIGH		0.75	SPH	3.4	30	69950	25	49	75	100	118
16	25	CCN	HIGH		0.75	SPH	3.4	30	67700	25	49	75	100	118
17	25	CCN	HIGH		0.75	SPH	3.4	30	67700	25	49	75	100	118
18	25	CCN	HIGH		0.75	SPH	3.4	30	67700	25	49	75	100	118
19	25	CCN	HIGH		0.75	SPH	3.4	30	67700	25	49	75	100	118
20	25	CCN	HIGH		0.75	SPH	3.4	30	67700	25	49	75	100	118
21	15	CCN	HIGH		0.75	SPH	3.4	30	66000	25	49	75	100	117
22	15	CCN	HIGH		0.75	SPH	3.4	30	66000	25	49	75	100	118
23	45	CCN	HIGH		1.00	ASPH	3.4	30	37000	18	37	56	75	91
24	45	CCN	HIGH		1.00	ASPH	3.4	30	37000	18	37	56	75	91
25	25	CCN	HIGH		1.00	ASPH	3.4	30	34977	18	37	56	75	91
26	25	CCN	HIGH		1.00	ASPH	3.4	30	34977	18	37	56	75	91
27	15	CCN	HIGH		1.00	ASPH	3.4	30	33000	18	37	56	75	90
28	15	CCN	HIGH		1.00	ASPH	3.4	30	33000	18	37	56	75	91

TABLE 14

RESULTS OF TRIAL COMPARISONS

USING KOLMOGOROV-SMIRNOV TEST \*\*

COMPARED TRIAL NUMBERS	I	I	SEEDING RADIUS (IN.)					I
			3	6	9	12	14.5	
6	5	*	49	37	77		77	I
6	6				47			I
8	5				47			I
9	1	*	95					I
10	8			72				I
13	11						41	I
13	4					46		I
13	3					48		I
14	12						47	I
16	15						38	I
22	21	*					92	I
22	14		91	70				I
22	9				70			I
22	1						47	I
25	22			53			59	I
25	21						48	I
25	14			38				I
25	4					35		I
25	1						39	I
26	19				39			I
26	7				91			I
26	6			35				I
27	11		60	75		57		I
28	18		64					I
28	17			64				I
28	10		49					I
28	4						51	I
29	26		49	35				I
30	29				91			I
30	13					46	42	I
30	10					90		I
30	7		49	72				I
31	24		88					I
31	17				36			I
31	15			47		79		I
32	17					37		I
32	16				91			I
34	20					34		I
34	4				67			I
35	30			75				I
35	10						34	I
35	7			69				I

TABLE 14 (CONTINUED)

36	33	I		38	91	I
36	12	I	70			I
36	4	I		77		I
37	32	I			54	I
37	28	I		63		I
37	24	I			97	I
37	15	I	70			I
38	29	I			98	I
38	13	I		38		I
38	15	I		52		I
38	6	I	70			I
39	39	I			37	I
39	29	I		39		I
39	3	I			34	I
40	2	I			41	I
41	40	I			40	I
41	1	I			67	I
42	33	I	79			I
42	6	I	49			I
42	4	I			62	I
43	24	I	77			I
43	13	I			59	I
44	22	I			40	I
		I				I

NUMBERS SHOWN IN TABLE ARE PERCENTAGE SIMILARITIES, FOR EXAMPLE, WHEN THE TRIALS 44 AND 22 ARE TESTED AT THE 12 INCH SEEDING RADIUS THEY CAN BE ACCEPTED TO BE FROM THE SAME PARENT POPULATION WITH A 40 % PROBABILITY OF BEING CORRECT.

\* DENOTES DUPLICATED TRIALS.

\*\* ONLY THOSE COMPARISONS OF TRIALS WITH SIMILARITY GREATER THAN 33.3 PER CENT ARE LISTED.

TABLE 15

RESULTS OF DUPLICATED TRIAL COMPARISONS

USING KOLMOGOROV-SMIRNOV TEST

DUPLICATED TRIAL NUMBERS	I	SEEDING RADIUS (IN.)					I
		3	6	9	12	14.5	
2	1	3.5	0.0	0.0	0.3	23.2	
4	3	0.0	0.0	0.0	18.4	6.8	
6	5	49.1	36.5	77.4	22.9	76.5	
8	7	0.0	0.0	0.0	0.0	0.0	
9	2	0.8	3.0	0.0	0.6	0.0	
9	1	94.8	2.4	0.2	0.0	0.0	
14	13	0.0	0.0	0.0	0.1	0.2	
18	17	0.0	0.0	0.0	0.0	0.2	
20	19	0.0	0.0	0.0	0.0	6.7	
22	21	0.0	0.0	0.0	0.0	91.8	
31	30	0.0	0.0	0.0	2.7	31.1	
42	10	0.0	0.0	0.0	0.0	23.2	
43	40	0.0	0.0	0.0	21.0	0.0	
44	41	0.0	0.0	0.0	14.7	20.6	

NUMBERS SHOWN IN TABLE ARE PERCENTAGE SIMILARITIES, FOR EXAMPLE, WHEN THE TRIALS 44 AND 41 ARE TESTED AT THE 12 INCH SEEDING RADIUS THEY CAN BE ACCEPTED TO BE FROM THE SAME PARENT POPULATION WITH A 14.7% PROBABILITY OF BEING CORRECT.

TABLE 16

TRIAL PAIRS WITH A SINGLE PARAMETER CHANGE

	TRIAL PAIR NUMBERS	
BASE ANGLE CHANGE	I 1-3,	1-4, 1-5, 1-6, 1-7, 1-8, 2-3, 2-4, I
	I 2-5,	2-6, 2-7, 2-8, 3-5, 3-6, 3-7, 3-8, I
	I 3-9,	4-5, 4-6, 4-7, 4-8, 4-9, 5-7, 5-8, I
	I 5-9,	6-7, 6-8, 6-9, 7-9, 8-9, 10-30, 10-31, I
	I 10-40,	10-41, 10-43, 10-44, 12-23, 12-24, 15-17, 15-18, I
	I 15-19,	15-20, 15-21, 15-22, 17-19, 17-20, 17-21, 17-22, I
	I 18-19,	18-20, 18-21, 18-22, 19-21, 19-22, 20-21, 20-22, I
	I 23-24,	23-25, 24-25, 30-40, 30-41, 30-42, 30-43, 30-44, I
	I 31-40,	31-41, 31-42, 31-43, 31-44, 40-41, 40-42, 40-44, I
	I 41-42,	41-43, 42-43, 42-44, 43-44, I
	I	
BASE SHAPE CHANGE	I 11-12, 11-25, 13-19, 13-20, 14-19, 14-20	I
	I	
PEBBLE DIAMETER CHANGE	I 10-24, 12-40, 12-43, 23-30, 23-31, 24-42, 25-40, 25-43, I	
	I 26-39, 27-38, 28-35, 29-33, 32,37, 34-36	I
I		
PEBBLE SHAPE CHANGE	I 11-13, 11-14, 12-19, 12-20, 15-23, 17-24, 18-24, 19-25, I	
	I 20-25, 26-29, 27-34, 28-32, 33-39, 35-37, 36-38	I
I		
PEBBLE SPECIFIC GRAVITY CHANGE	I 26-27, 29-34, 33-36, 38-39	I
	I	
I		
PEBBLE BED HEIGHT CHANGE	I 5-26, 6-26, 15-16, 27-32, 28-34, 35-36, 37-38	I
	I	
I		

THE TABULATED VALUES ARE THE FREQUENCIES OF OCCURRENCE OF TYPE E AND TYPE F SPECTRA, THE FREQUENCIES BEING EXPRESSED AS THE PERCENTAGE OF SPECTRAL TYPES AT EACH SLEEPING POSITION.

TABLE 17

EFFECT OF BASE SHAPE ON TRANSIT NUMBER

TRIAL NUMBER	I	SEEDING RADIUS (IN.)					I
		3	6	9	12	14.5	
	I	SPHERICAL PEBBLE, CONICAL BASE					I
19	I	0.61	0.65	0.75	0.96	1.58	I
	I	(0.01)	(0.02)	(0.03)	(0.09)	(0.29)	I
20	I	0.64	0.69	0.79	0.98	1.58	I
	I	(0.01)	(0.01)	(0.02)	(0.06)	(0.19)	I
	I	SPHERICAL PEBBLE, HEXAGONAL BASE					I
13	I	0.51	0.56	0.67	0.91	1.99	I
	I	(0.01)	(0.01)	(0.01)	(0.06)	(0.53)	I
14	I	0.48	0.52	0.64	0.88	2.37	I
	I	(0.01)	(0.01)	(0.03)	(0.08)	(0.82)	I
	I	ASPHERICAL PEBBLE, CONICAL BASE					I
12	I	0.57	0.61	0.67	0.87	2.43	I
	I	(0.01)	(0.01)	(0.02)	(0.05)	(0.76)	I
25	I	0.49	0.52	0.63	0.90	3.17	I
	I	(0.01)	(0.01)	(0.03)	(0.07)	(1.96)	I
	I	ASPHERICAL PEBBLE, HEXAGONAL BASE					I
11	I	0.61	0.64	0.73	0.95	1.95	I
	I	(0.01)	(0.01)	(0.02)	(0.05)	(0.43)	I

MEAN AND STANDARD DEVIATION VALUES OF TRANSIT NUMBER SPECTRA, VALUES OF STANDARD DEVIATION ARE IN BRACKETS.

TABLE 12

EFFECT OF PEBBLE BED HEIGHT

AVERAGE CF	SEEDING RADIUS (IN.)				
	3	6	9	12	14.5
-----					
	PEBBLE BED HEIGHT 24 IN.				
MEANS	0.62	0.67	0.79	1.01	1.43
STANDARD DEVIATIONS	0.01	0.02	0.03	0.05	0.11
-----					
	PEBBLE BED HEIGHT 28 IN.				
MEANS	0.70	0.72	0.77	0.87	1.03
STANDARD DEVIATIONS	0.01	0.01	0.02	0.03	0.05
-----					
	PEBBLE BED HEIGHT 30 IN.				
MEANS	0.74	0.77	0.83	0.96	1.24
STANDARD DEVIATIONS	0.01	0.01	0.02	0.03	0.09

AVERAGE VALUES OF MEANS AND STANDARD DEVIATIONS OF TRANSIT NUMBER SPECTRA FOR ALL SEEDING RADII AT VARIOUS PEBBLE BED HEIGHTS (35 DEGREE BASE ANGLE ONLY).

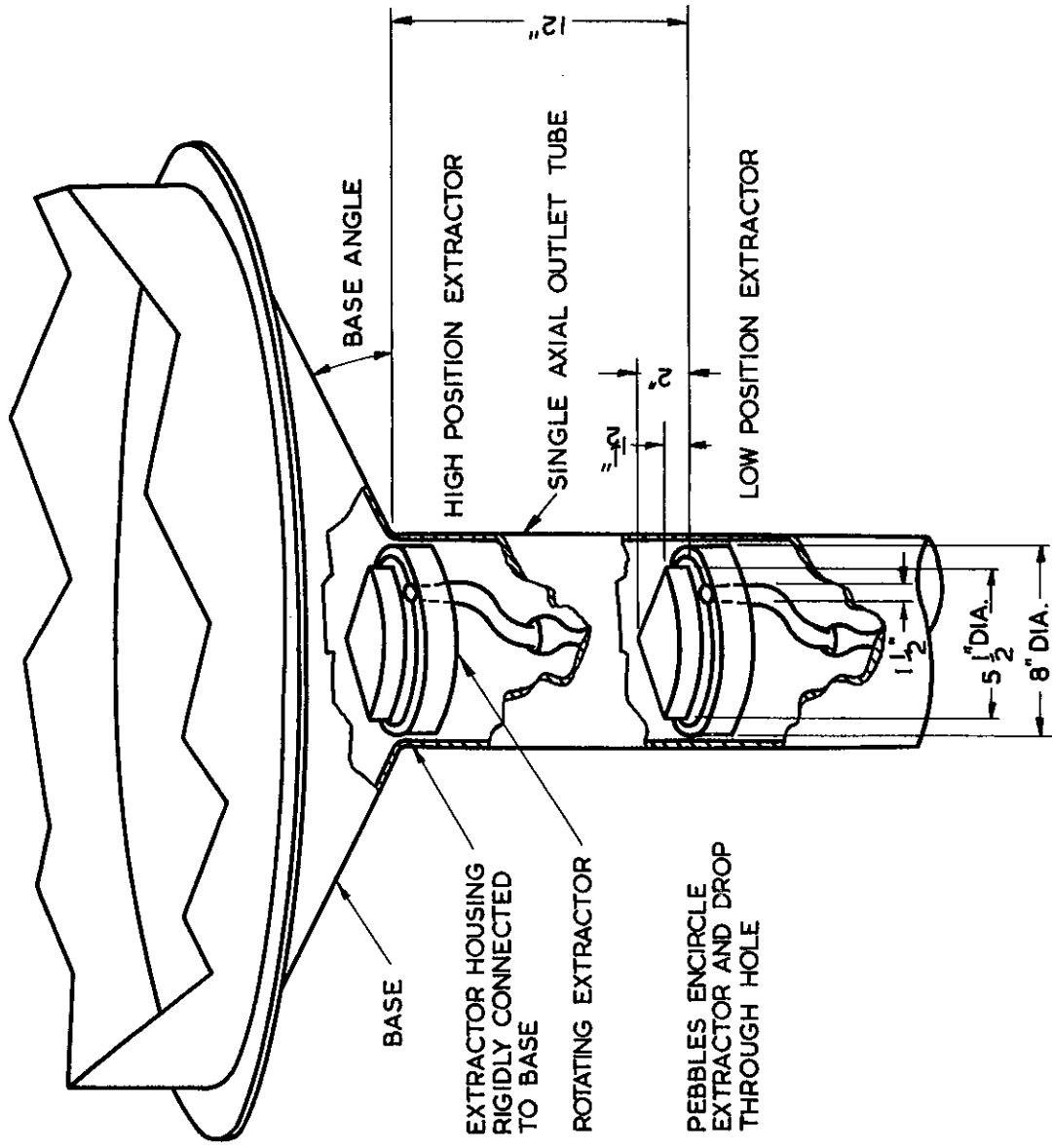
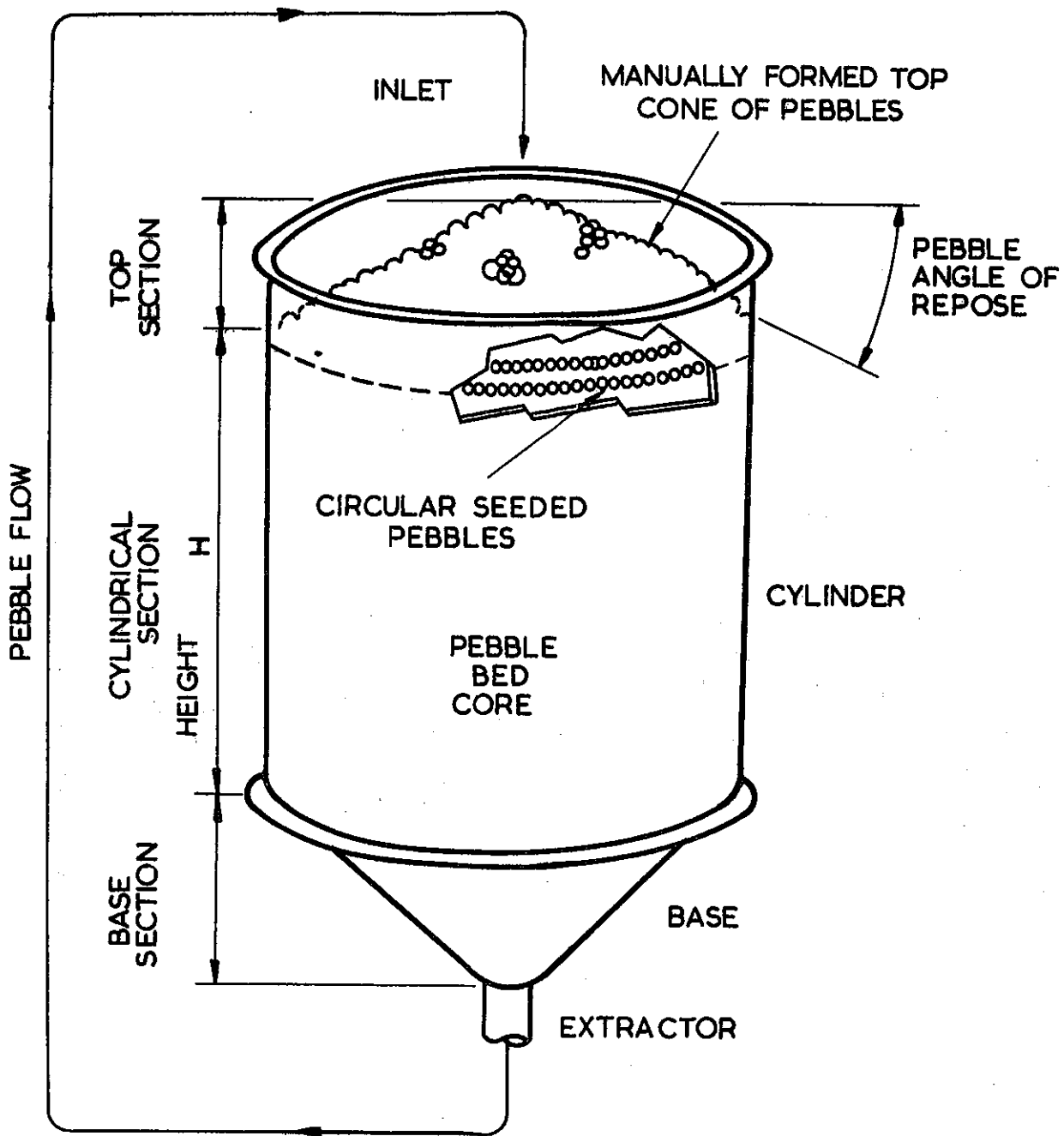
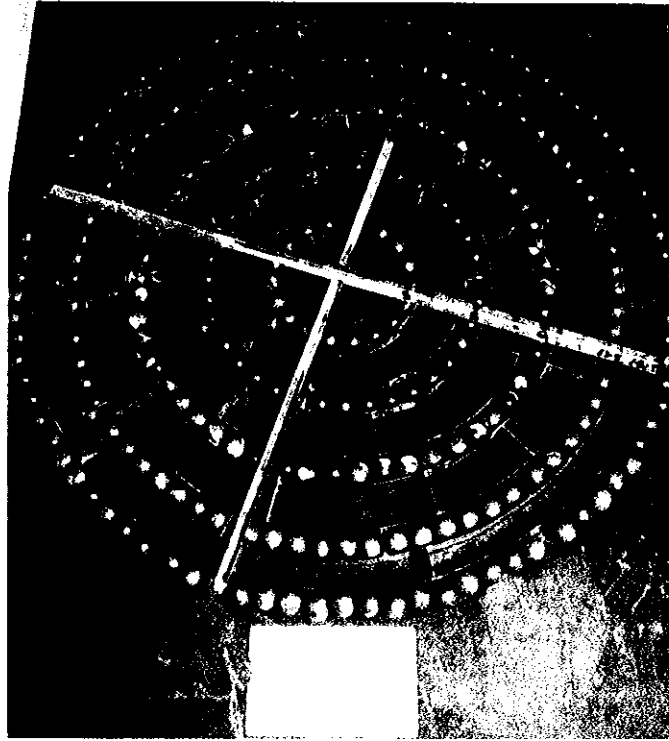

FIGURE 1. EXTRACTOR AND BASE



**FIGURE 2. FULLY SEEDED PEBBLE BED BEFORE RECIRCULATION**



**FIGURE 3. PEBBLE SEEDING JIG**

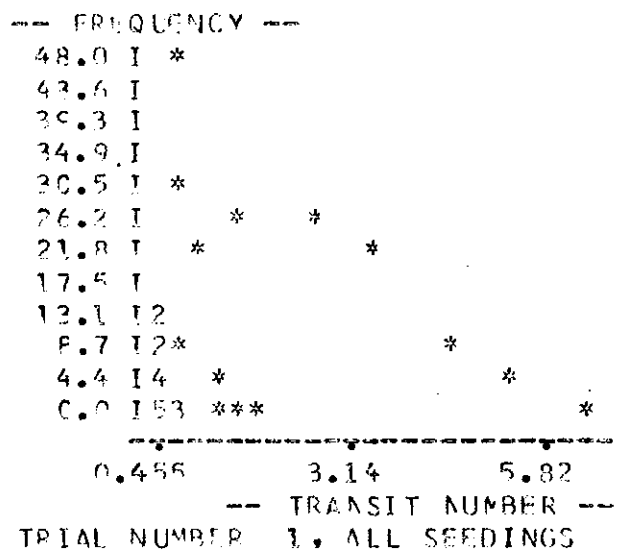
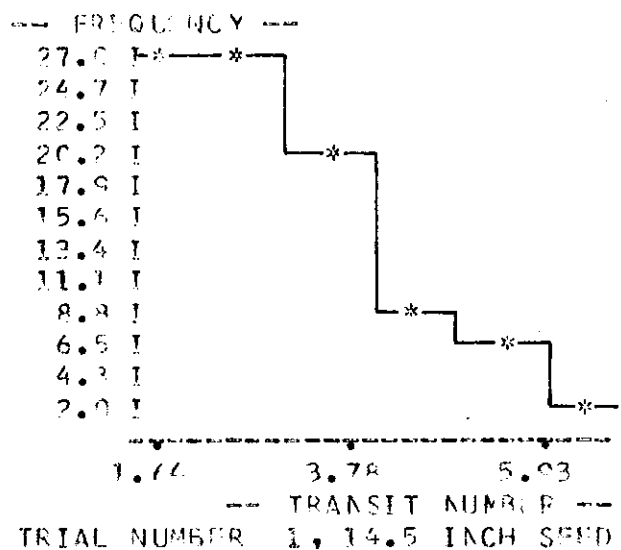
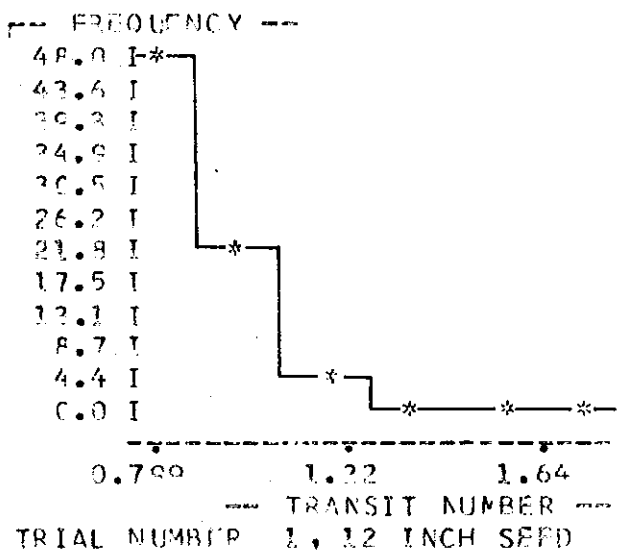
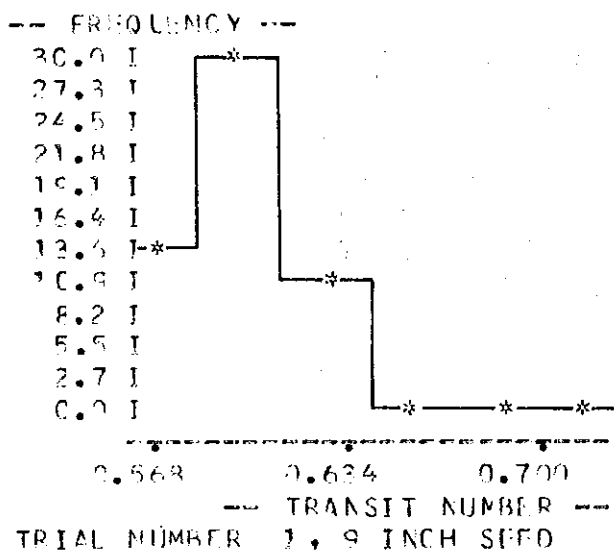
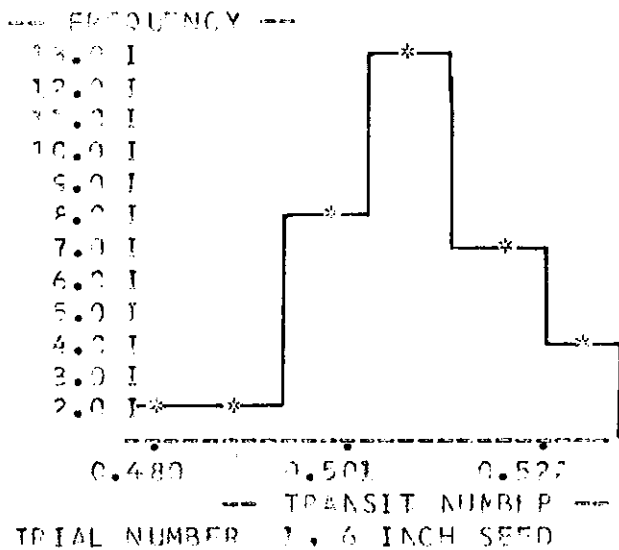
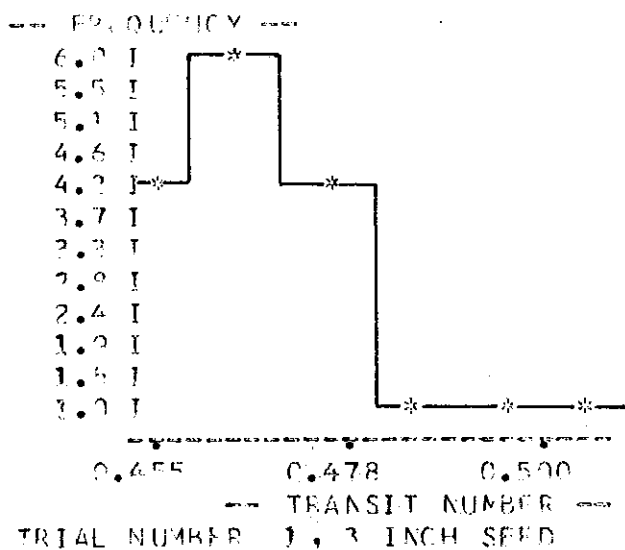

FIGURE 4

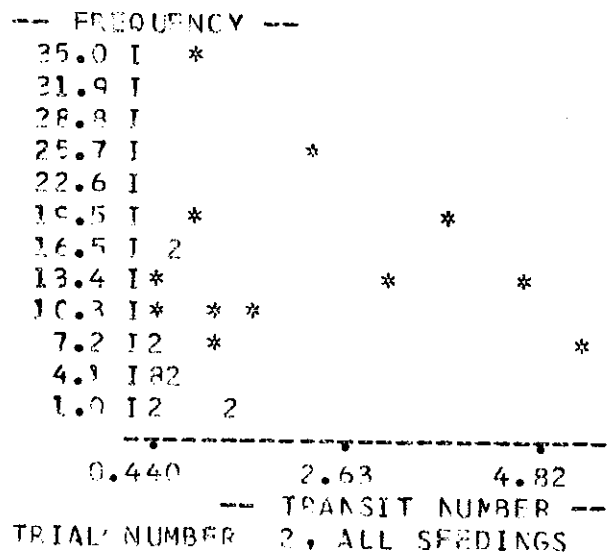
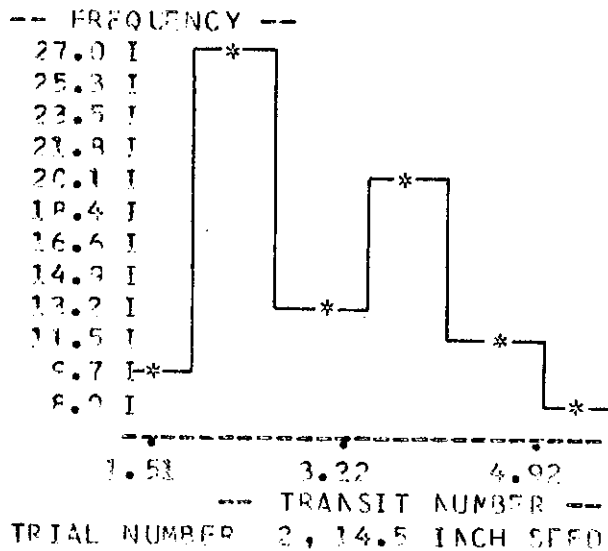
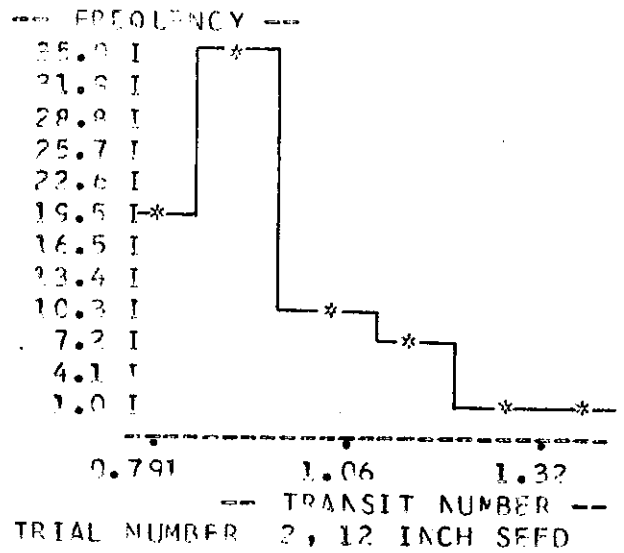
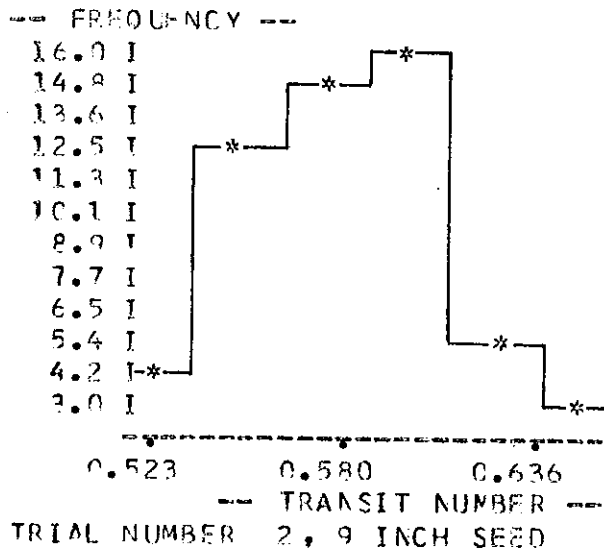
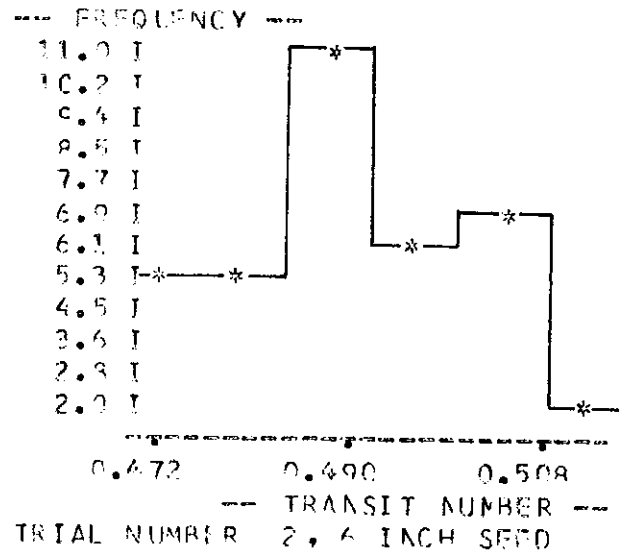
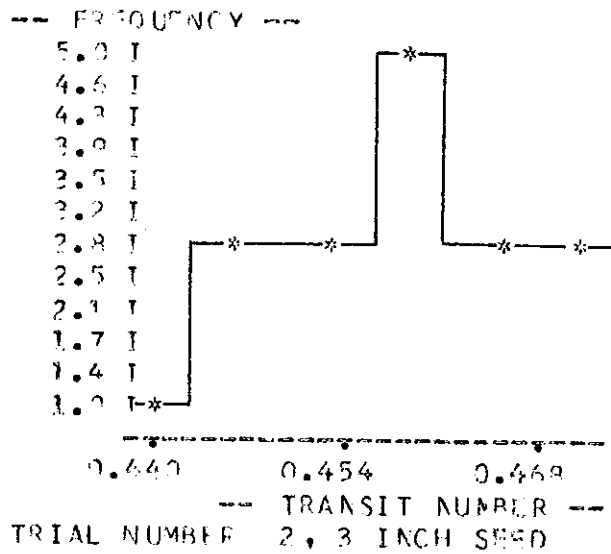
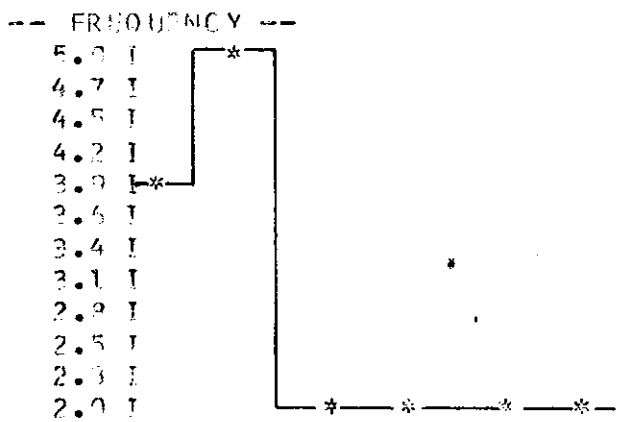
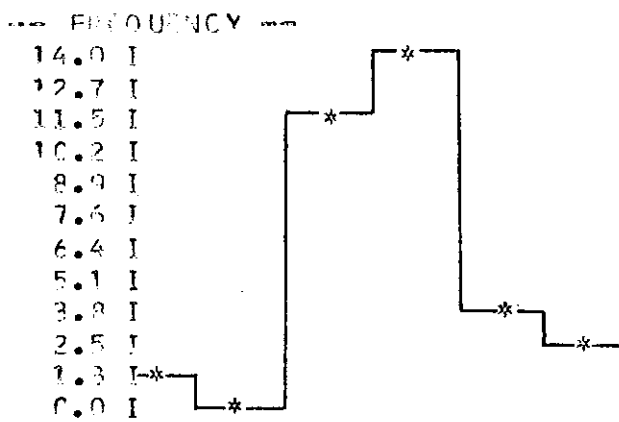

FIGURE 5



TRIAL NUMBER 3, 3 INCH SEED



TRIAL NUMBER 3, 6 INCH SEED

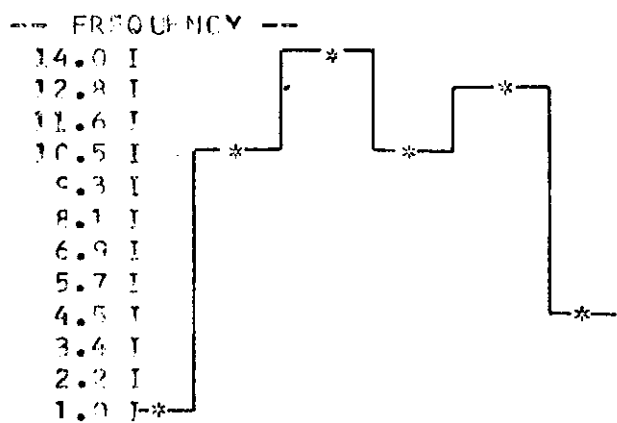

TRIAL NUMBER 3, 9 INCH SEED

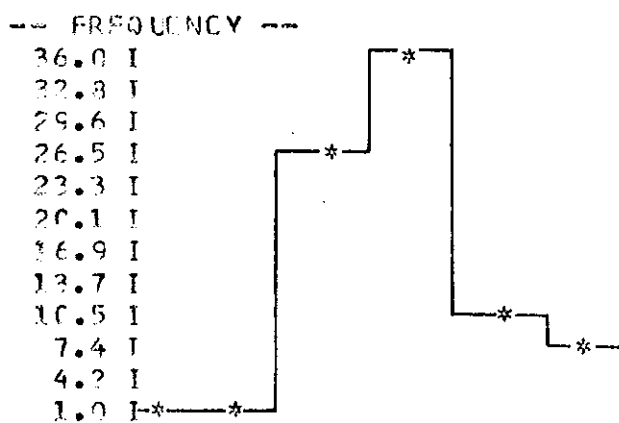

TRIAL NUMBER 3, 12 INCH SEED

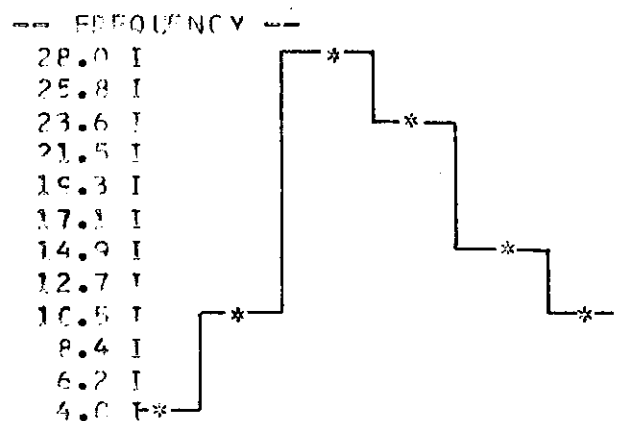

TRIAL NUMBER 3, 14.5 INCH SEED

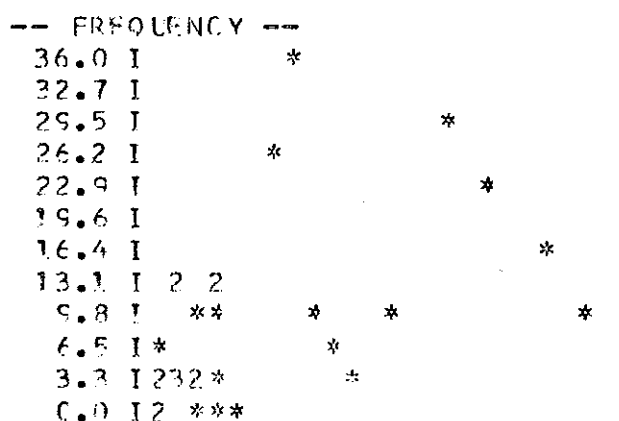

TRIAL NUMBER 3, ALL SEEDINGS

FIGURE 6

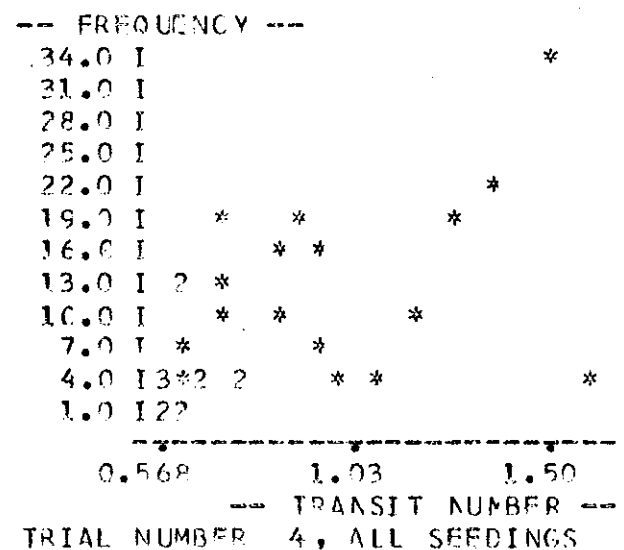
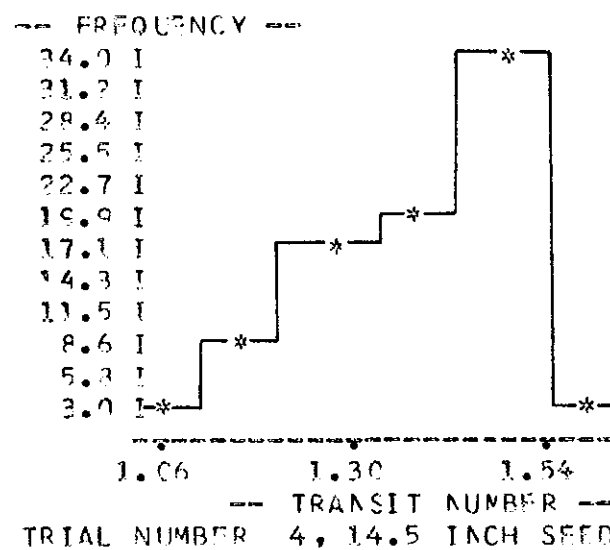
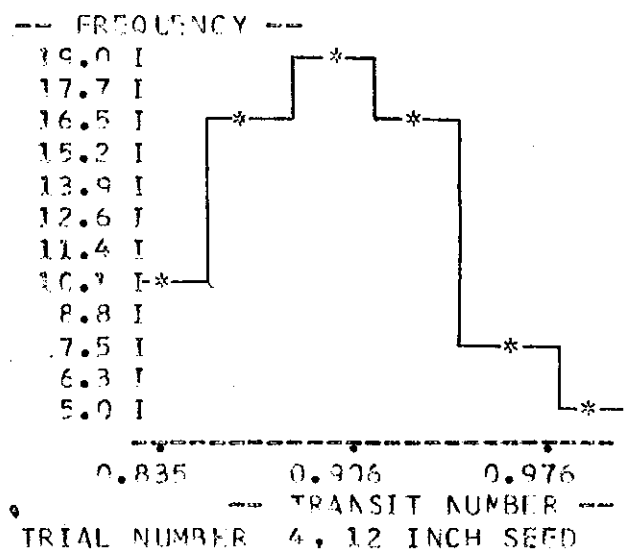
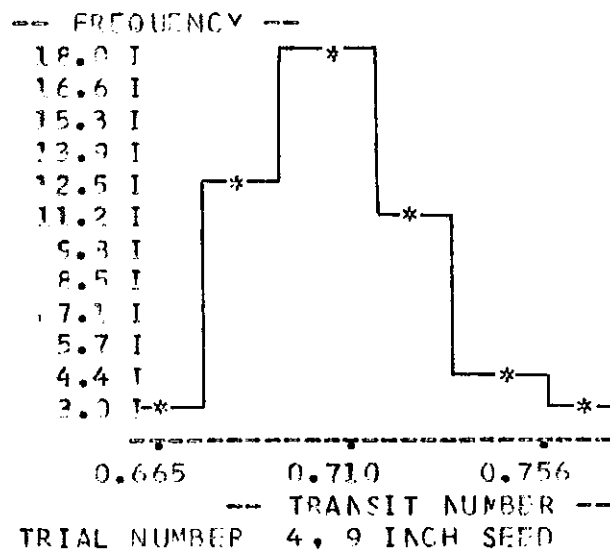
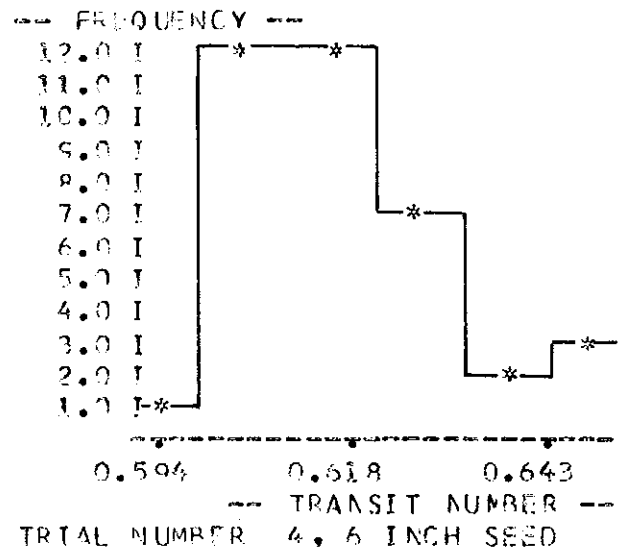
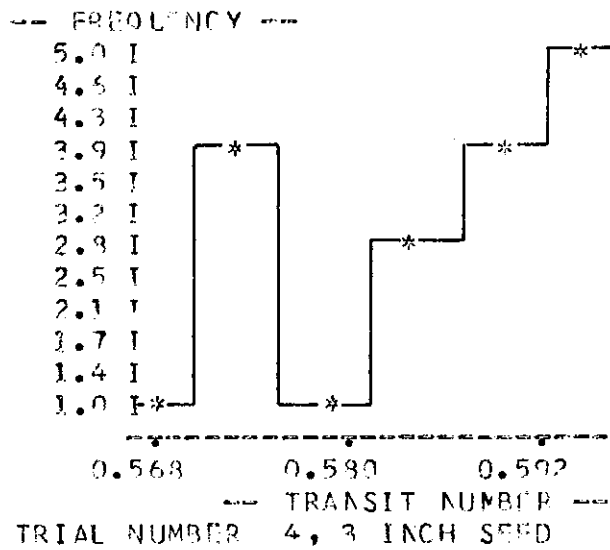

FIGURE 7

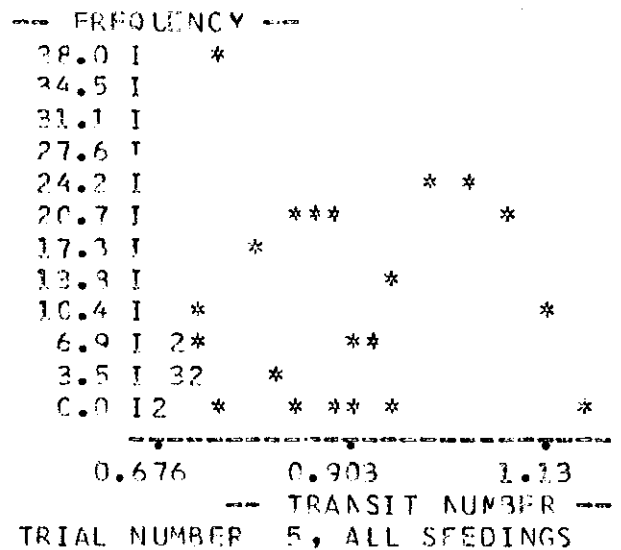
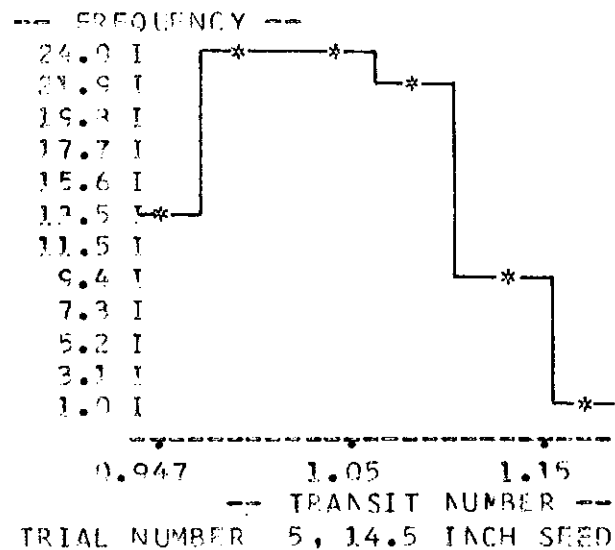
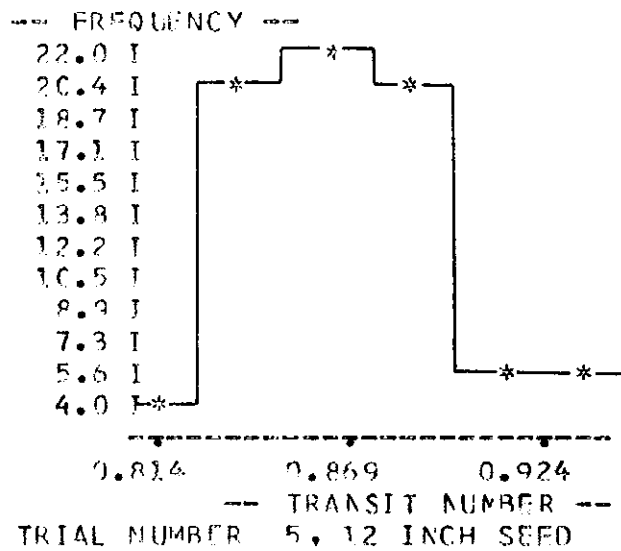
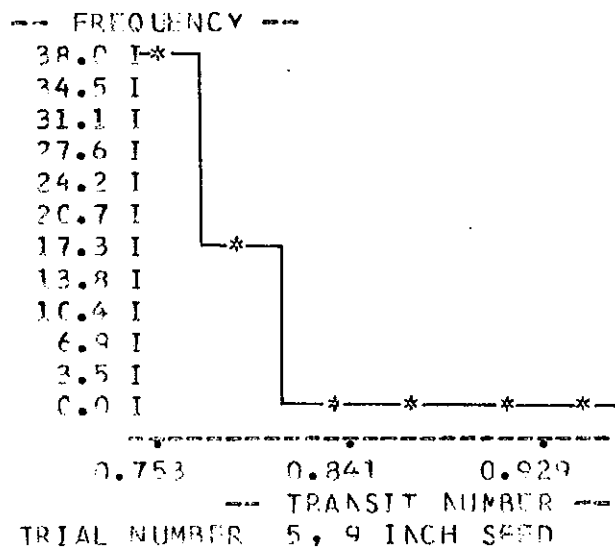
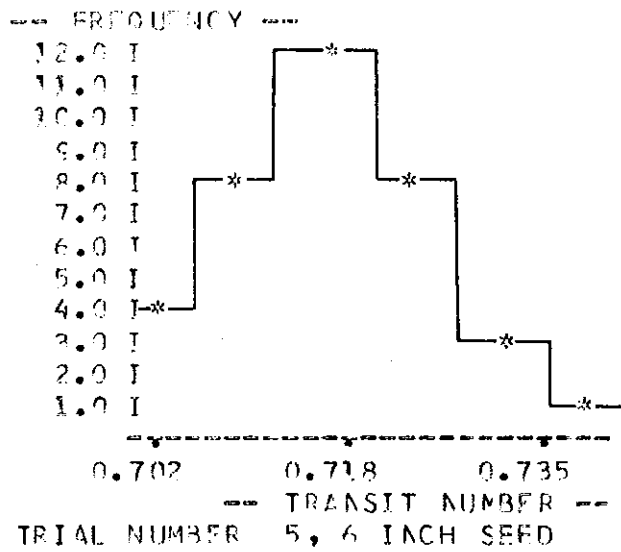
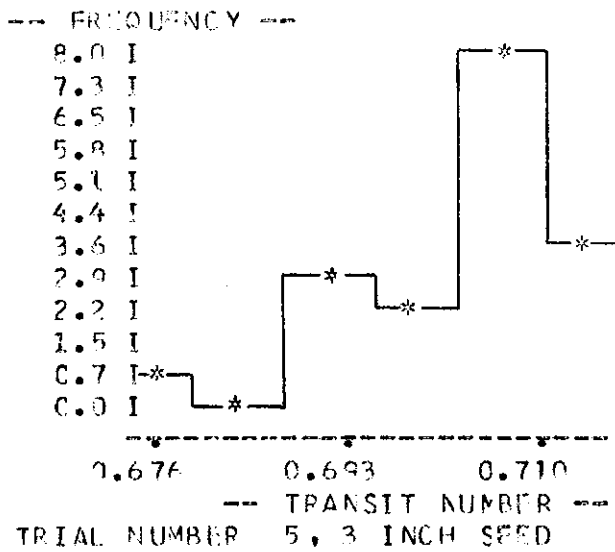

FIGURE 8

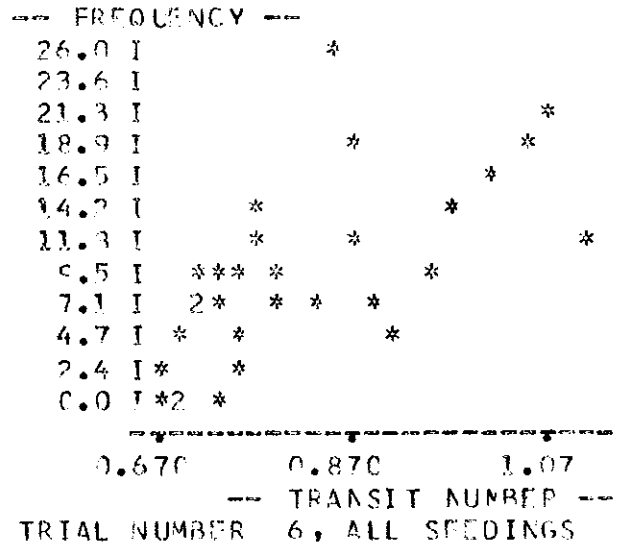
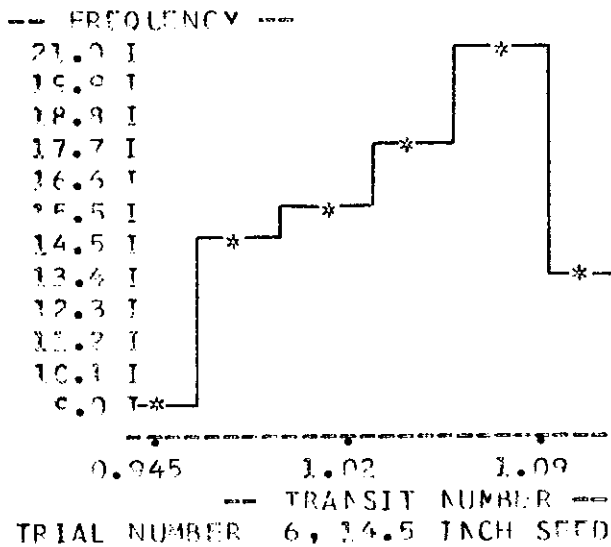
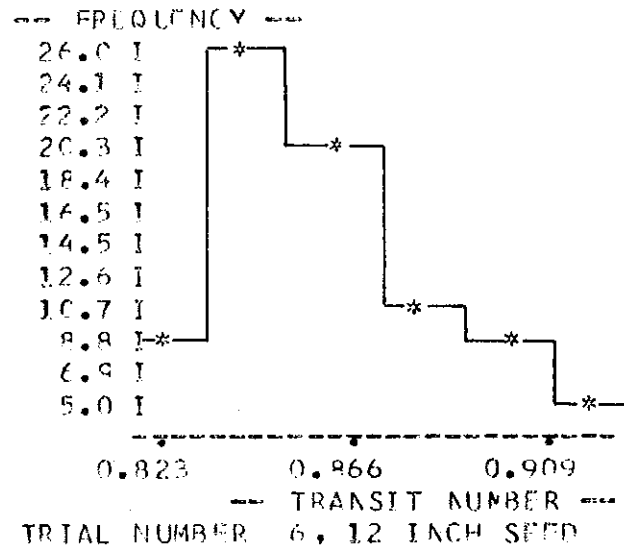
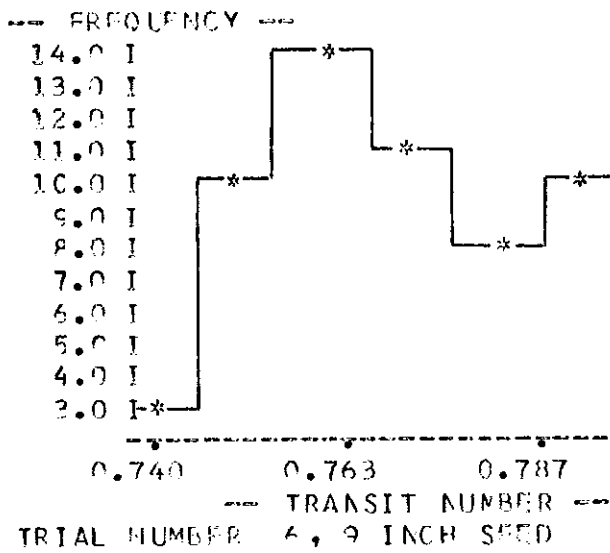
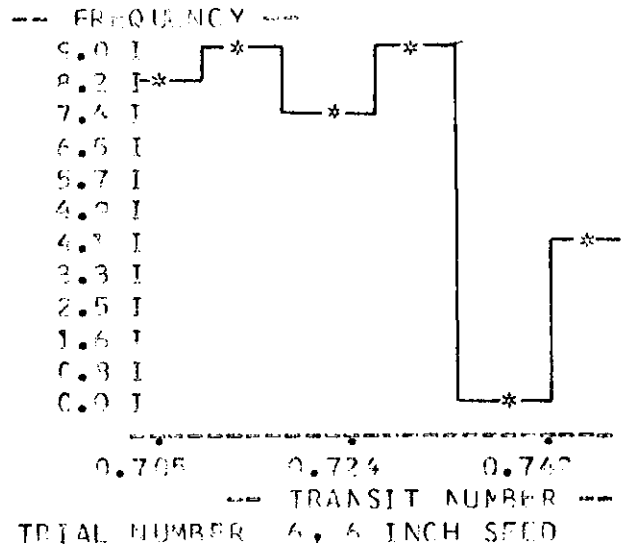
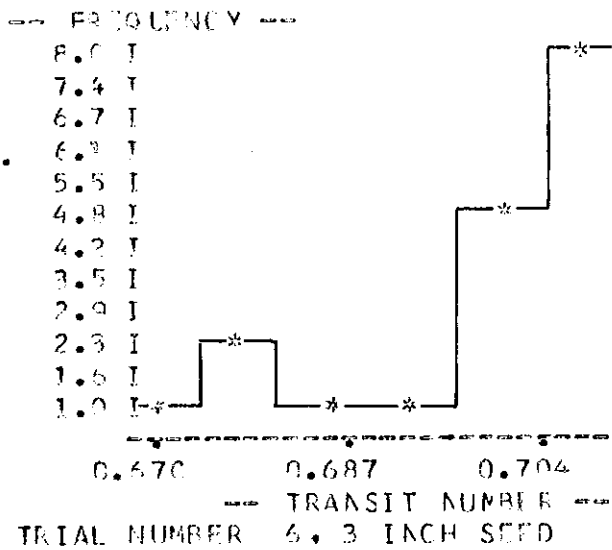

FIGURE 9

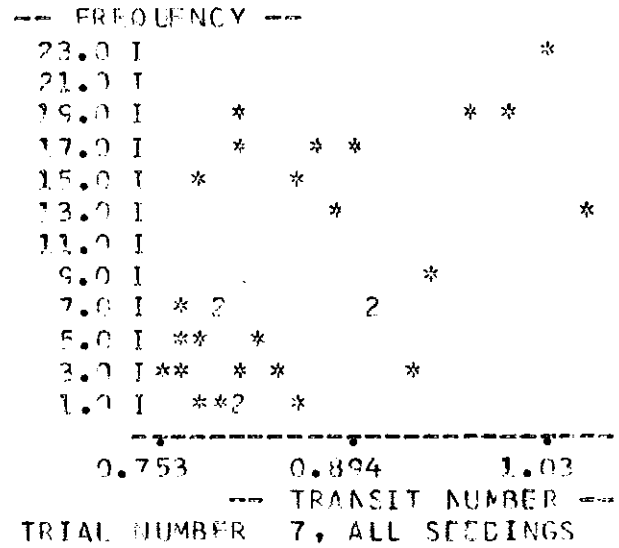
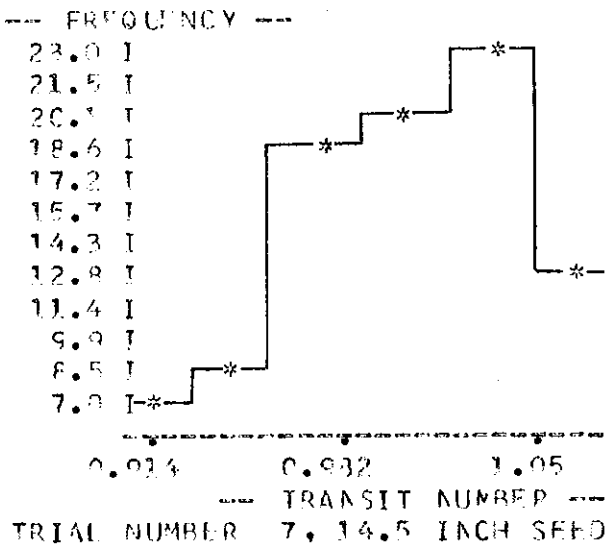
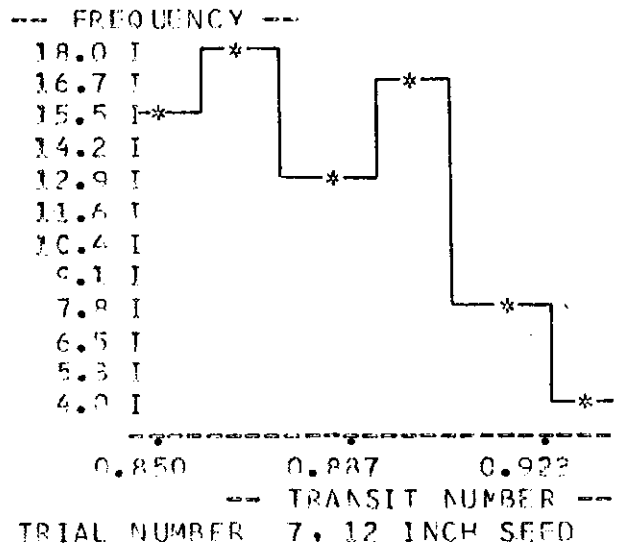
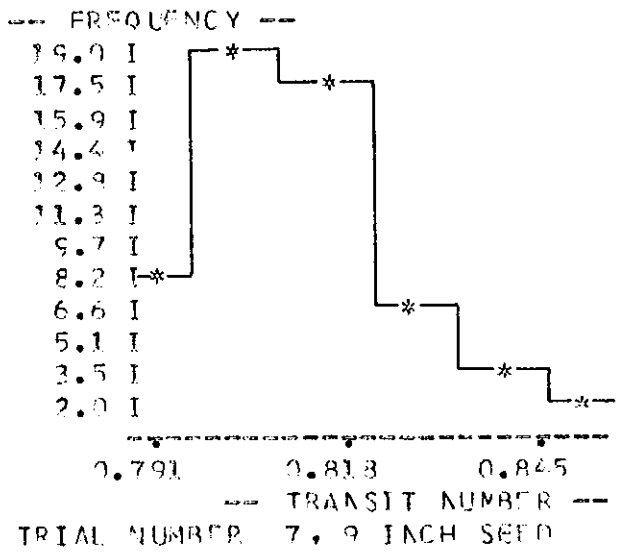
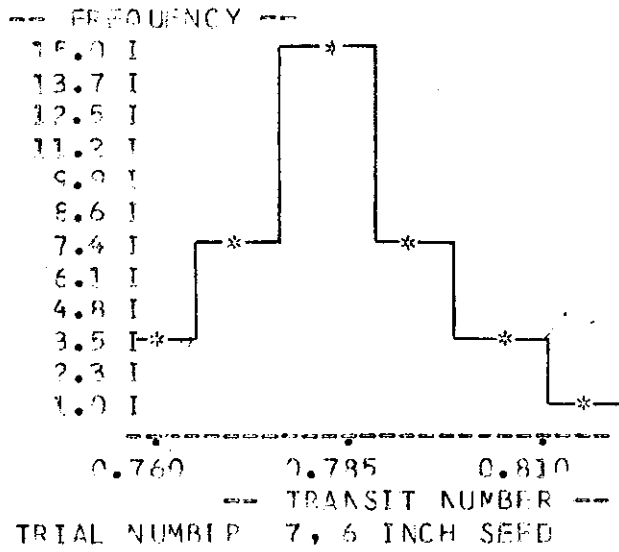
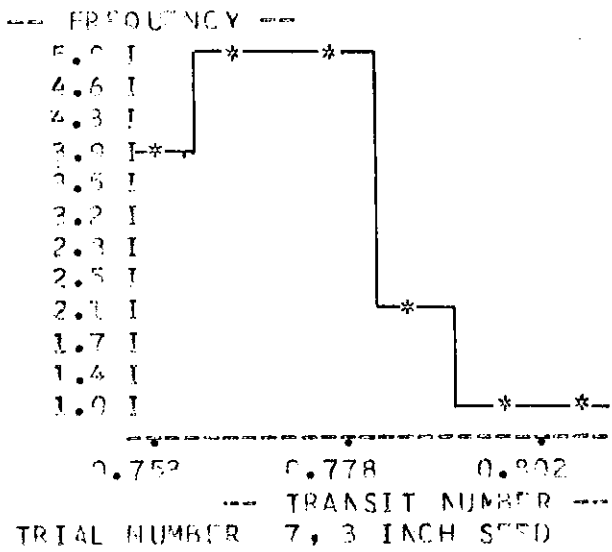

FIGURE 10

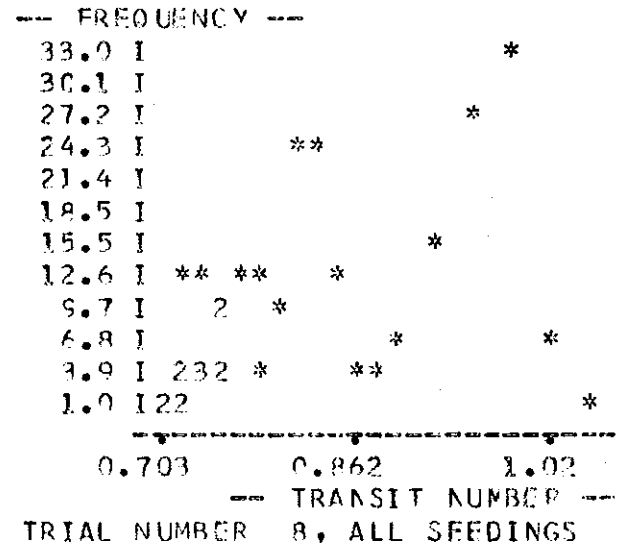
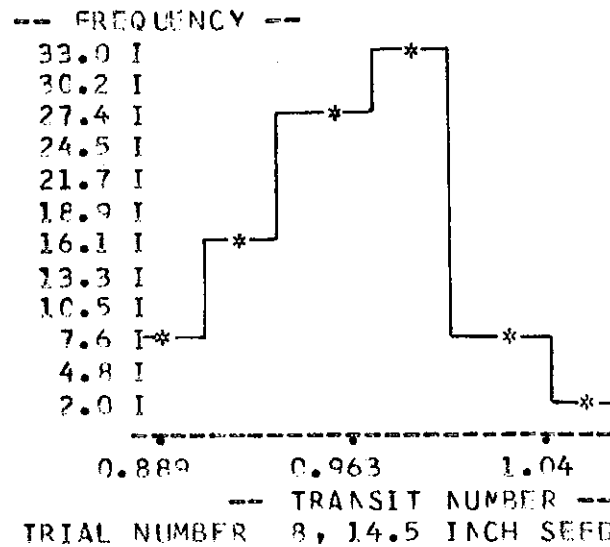
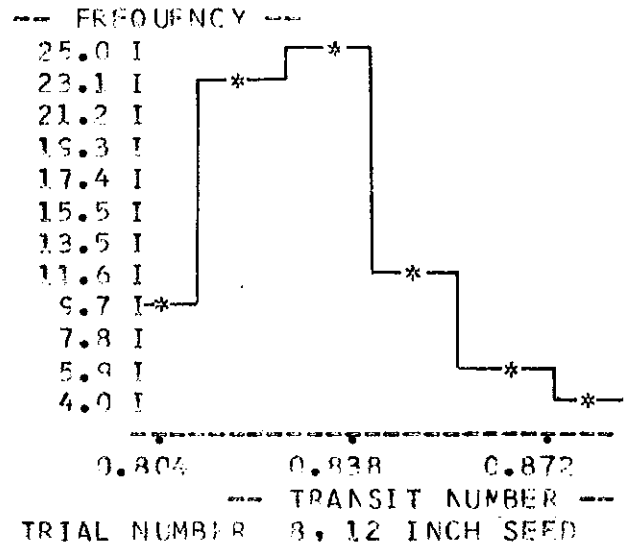
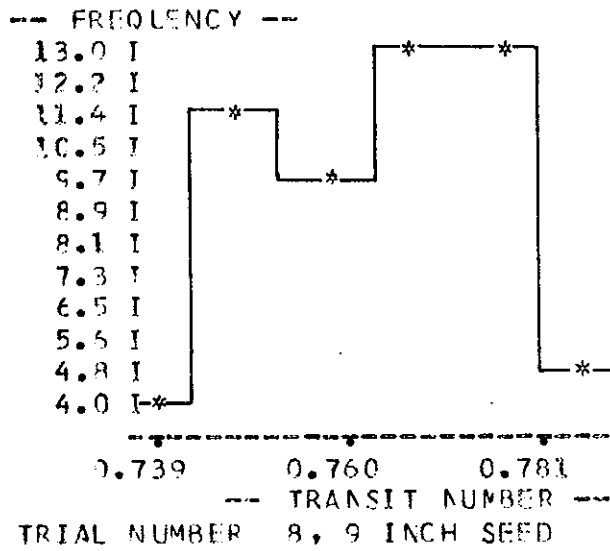
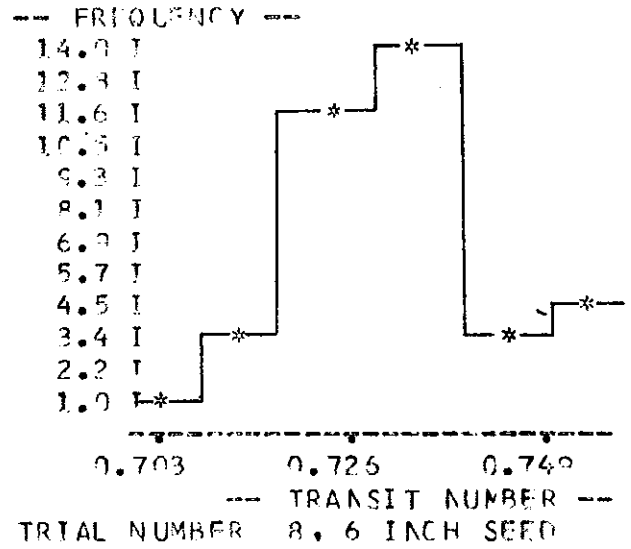
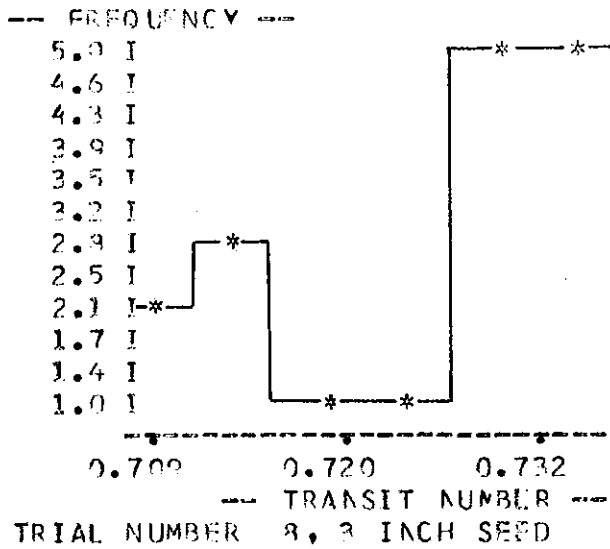

FIGURE 11

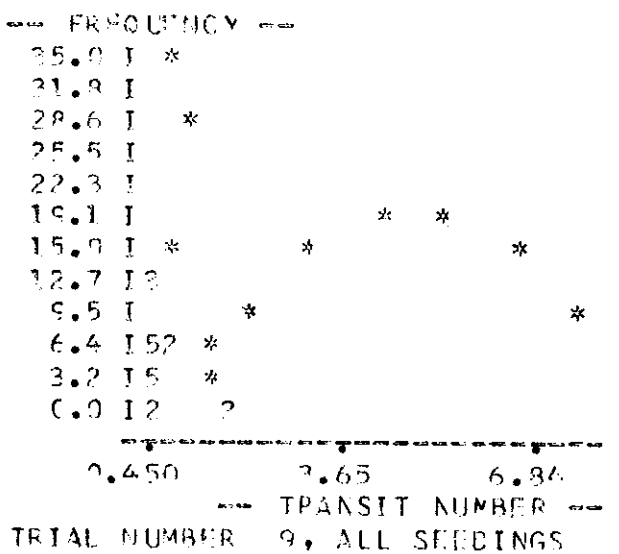
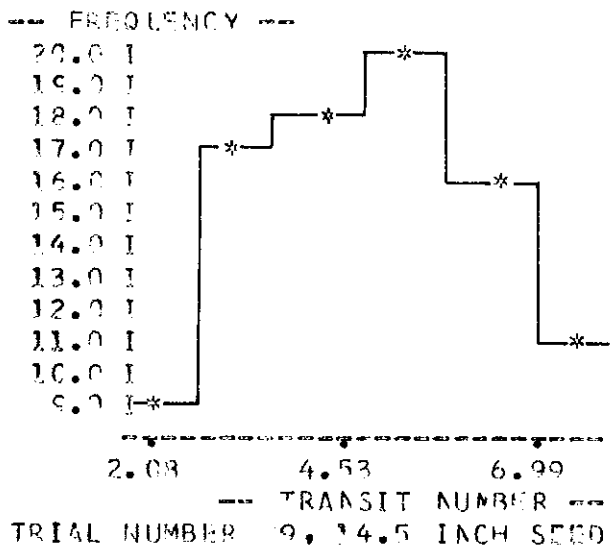
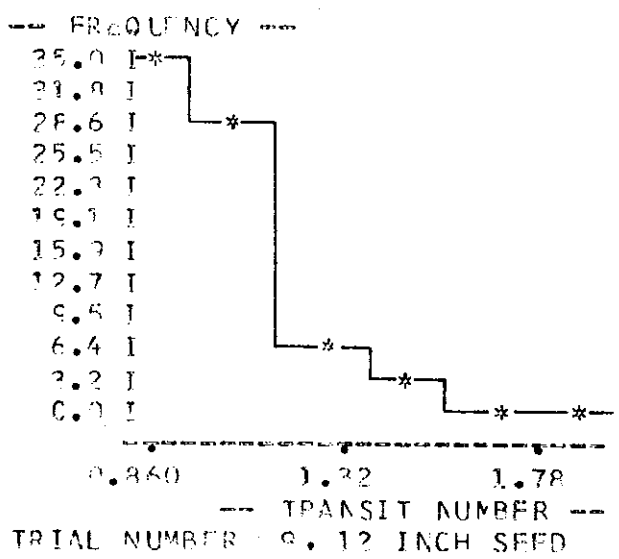
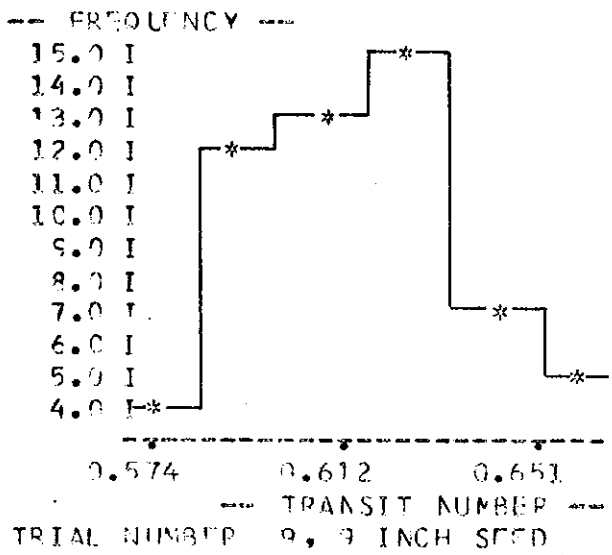
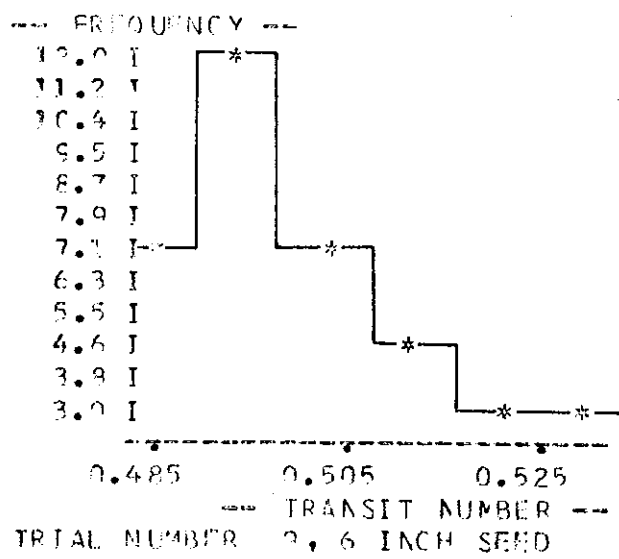
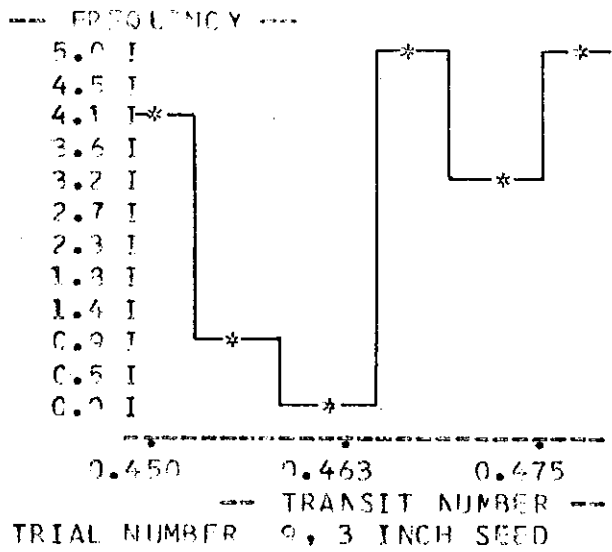

FIGURE 12

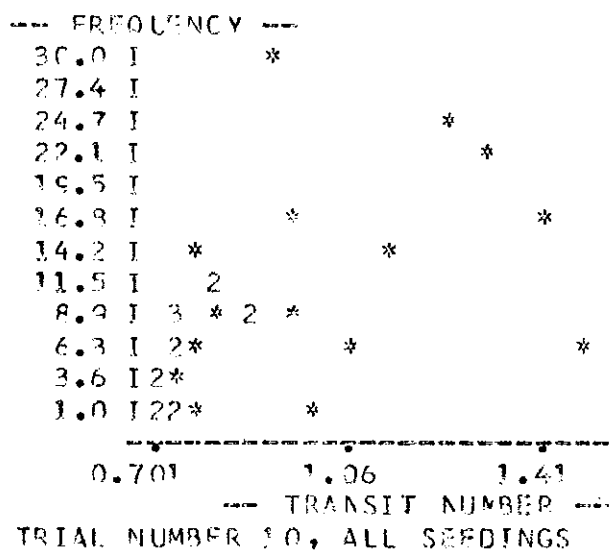
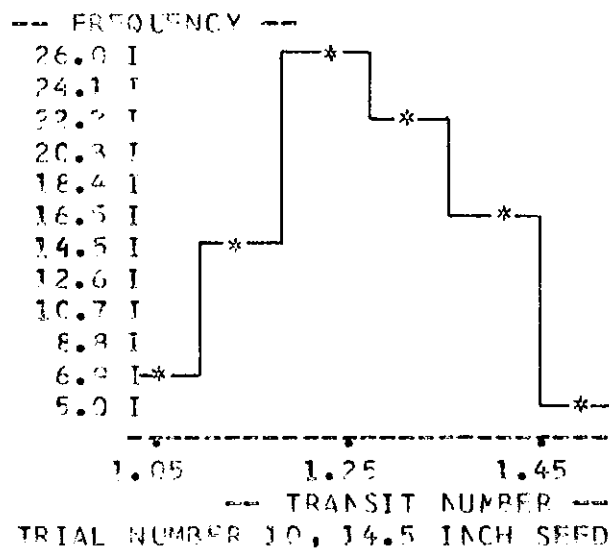
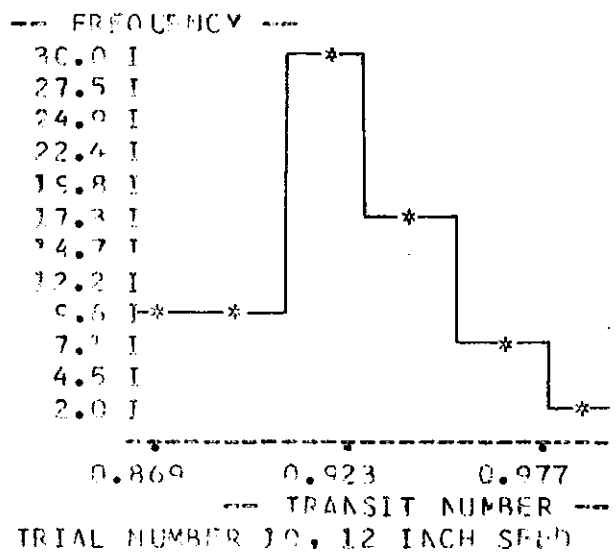
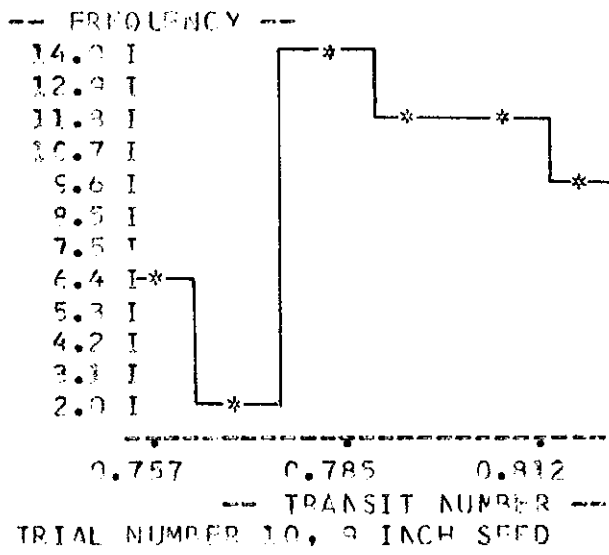
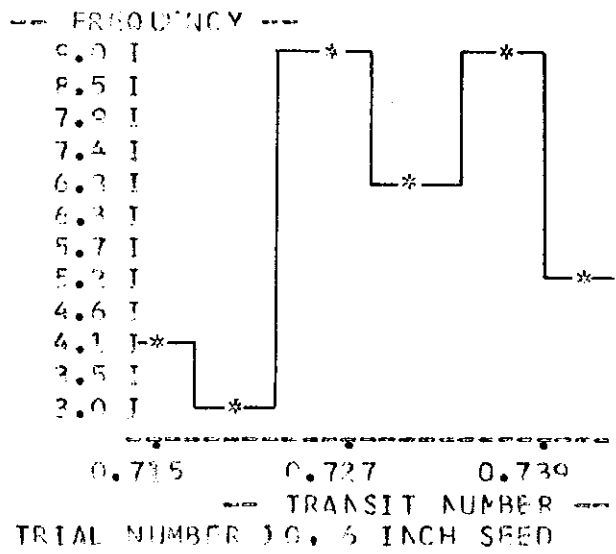
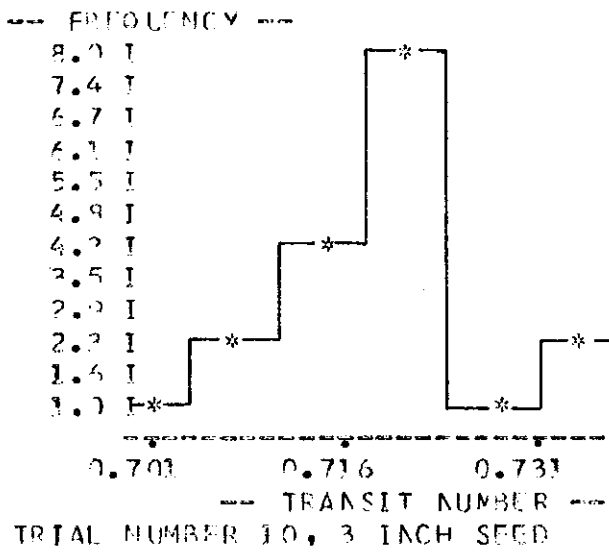

FIGURE 13

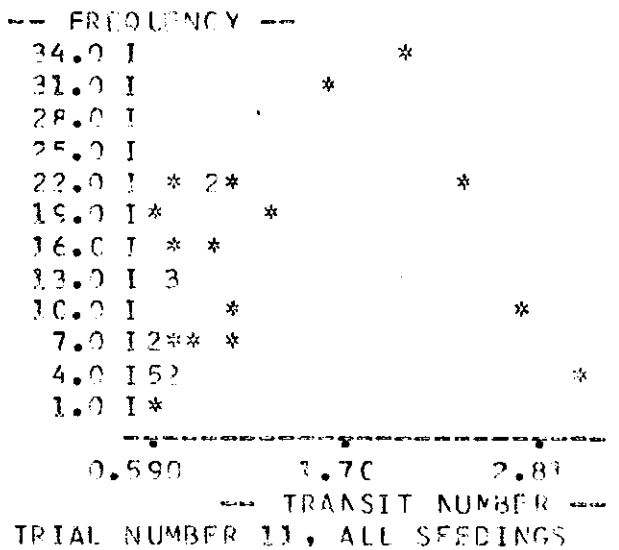
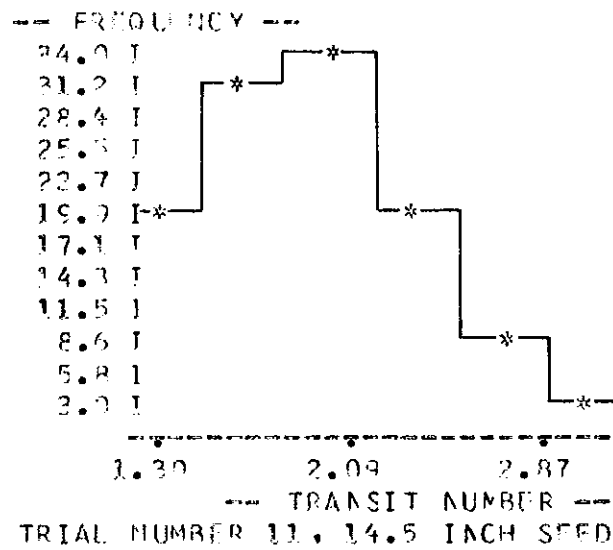
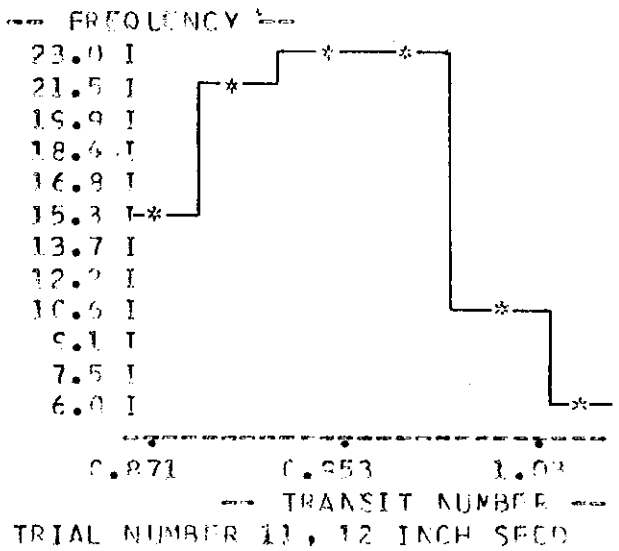
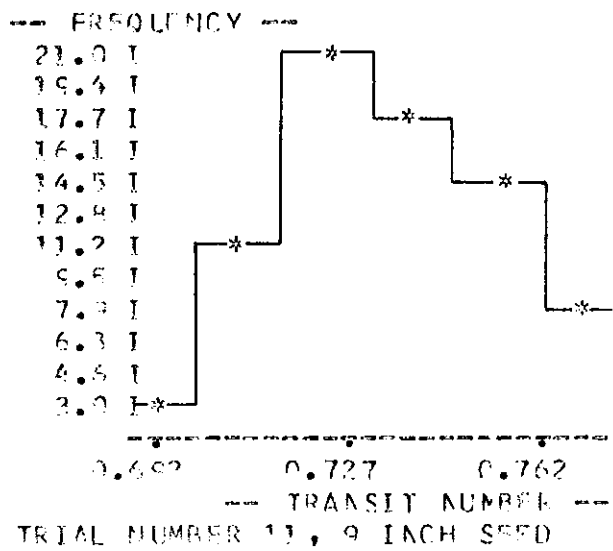
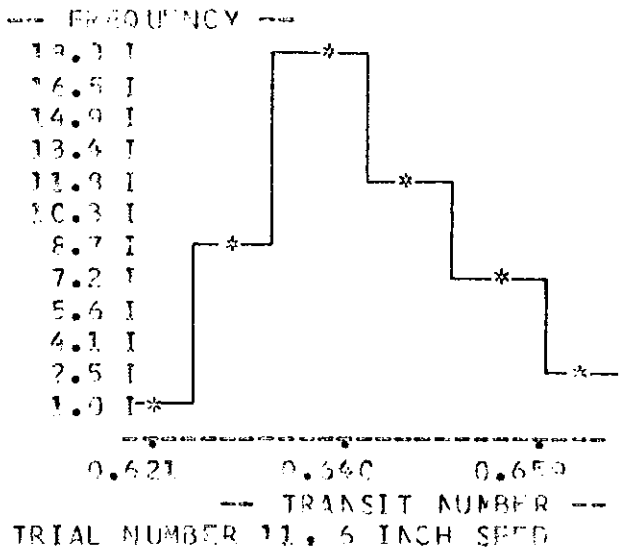
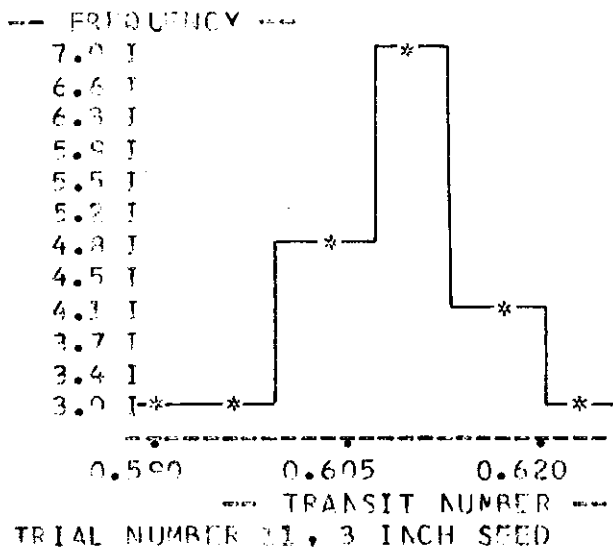

FIGURE 14

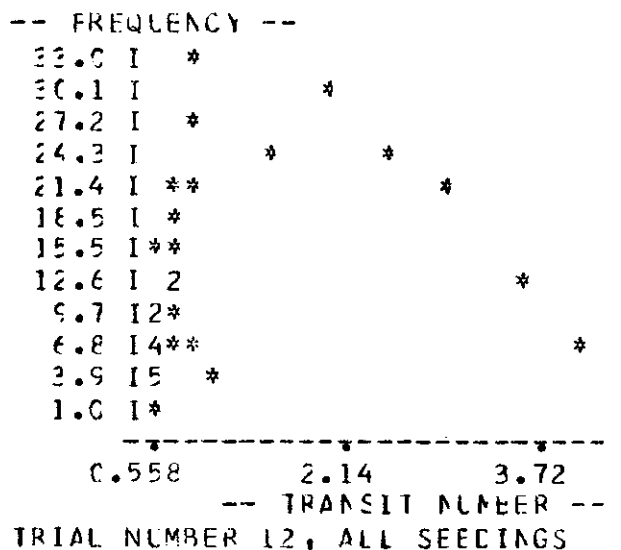
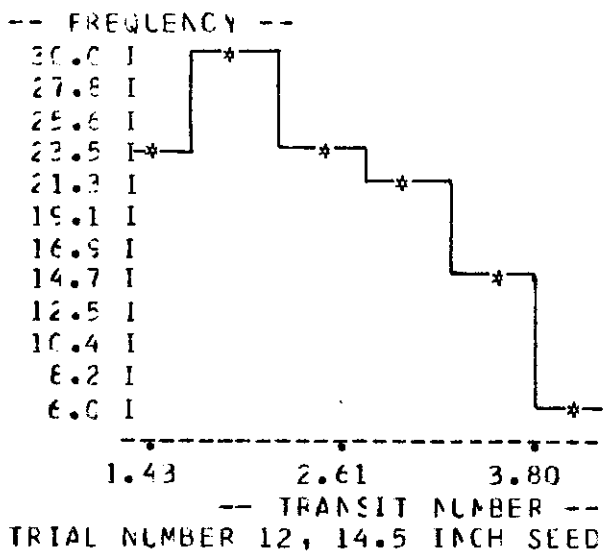
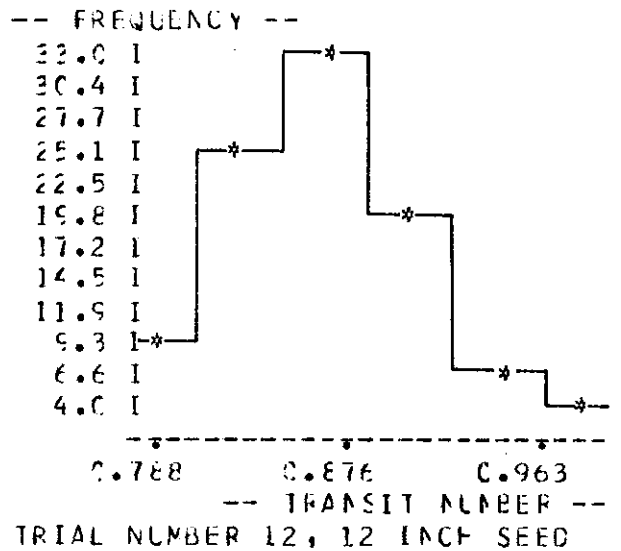
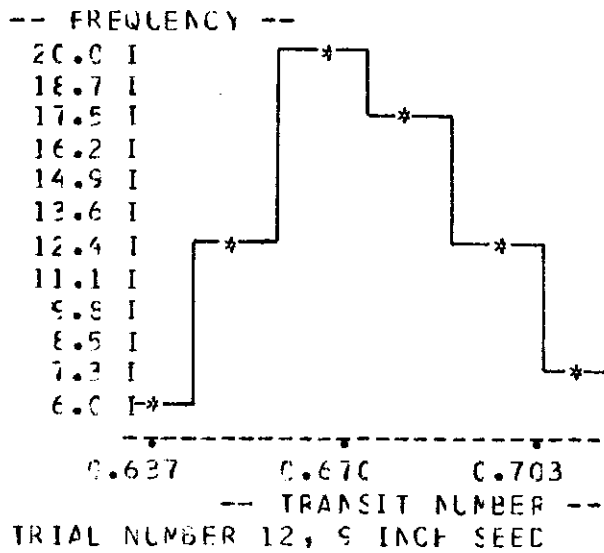
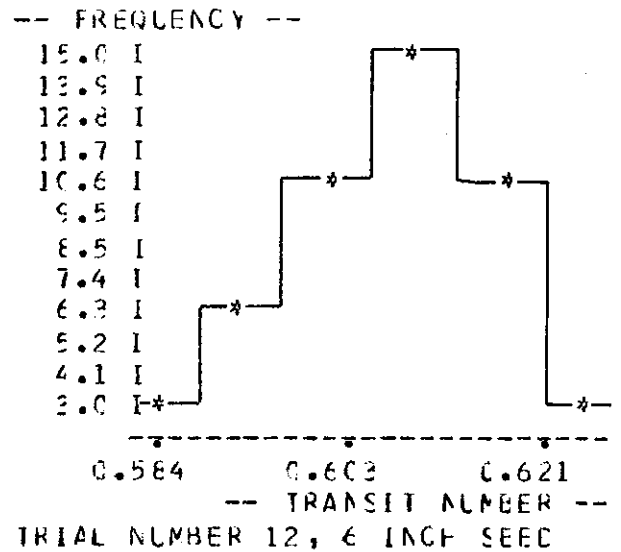
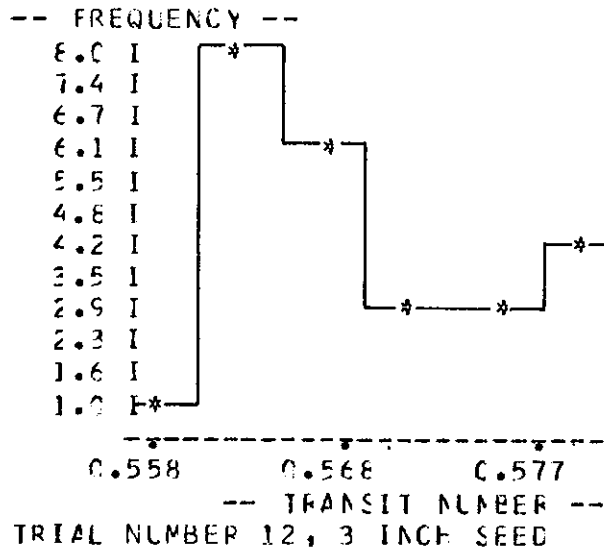

FIGURE 15

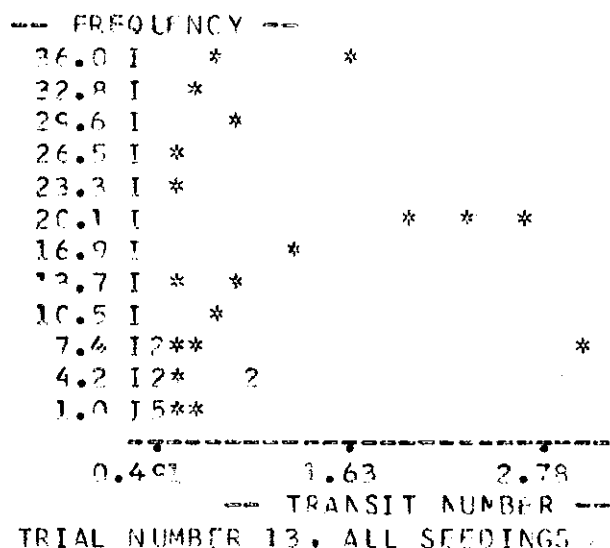
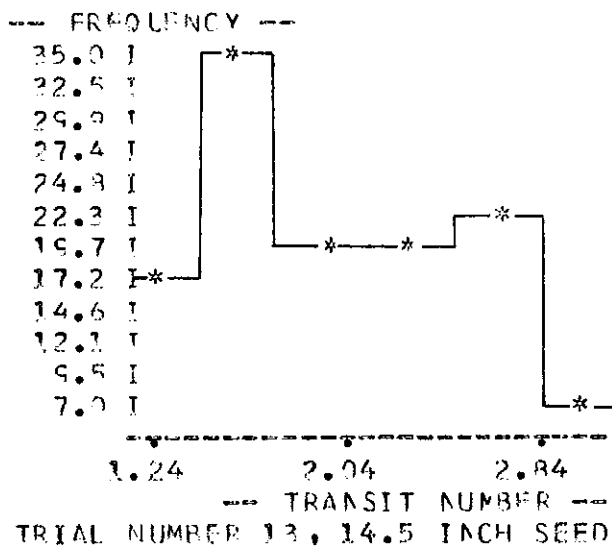
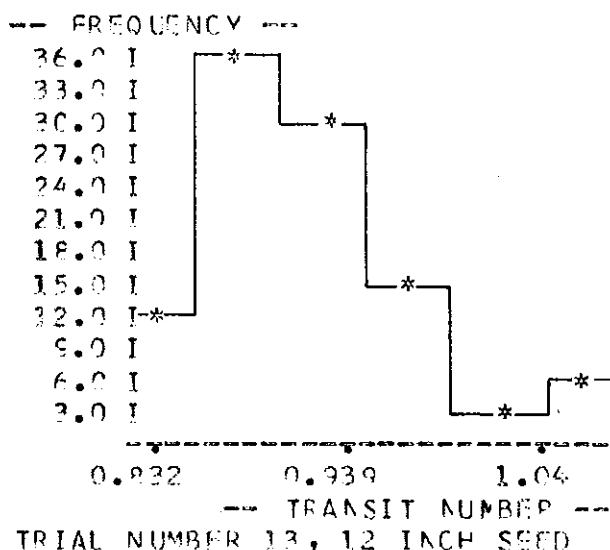
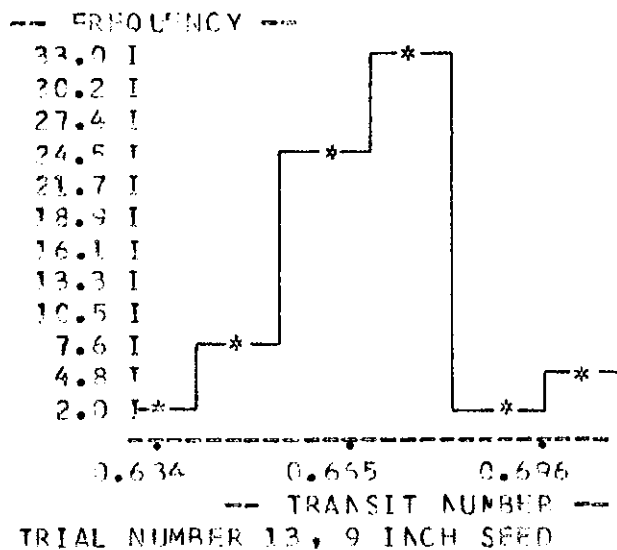
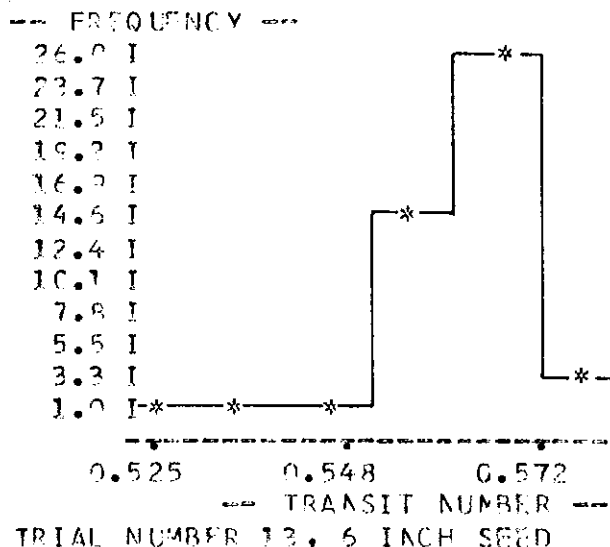
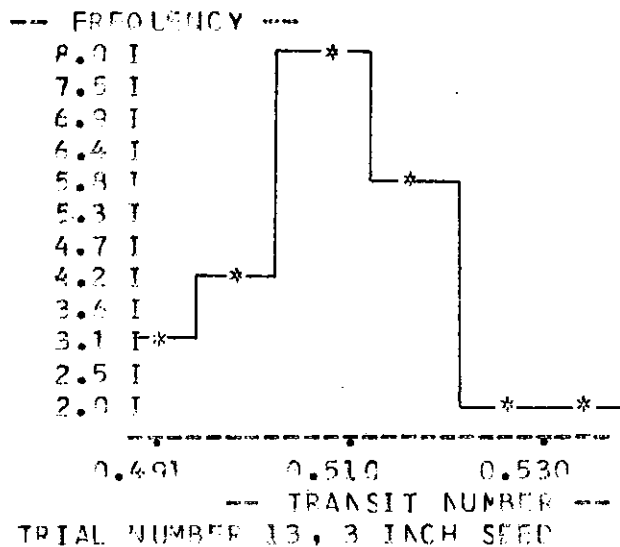

FIGURE 16

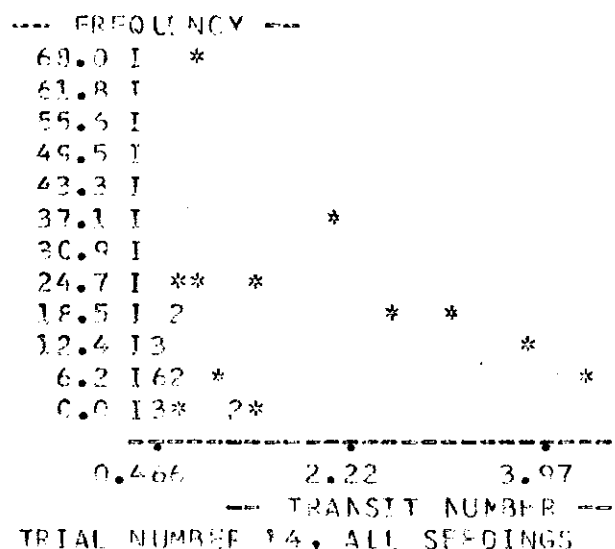
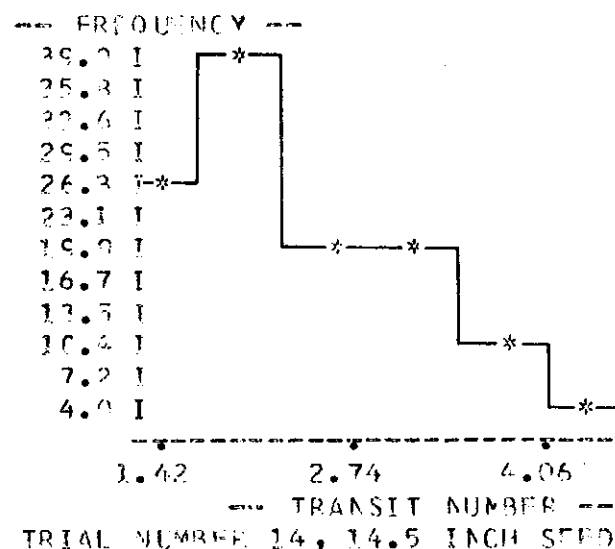
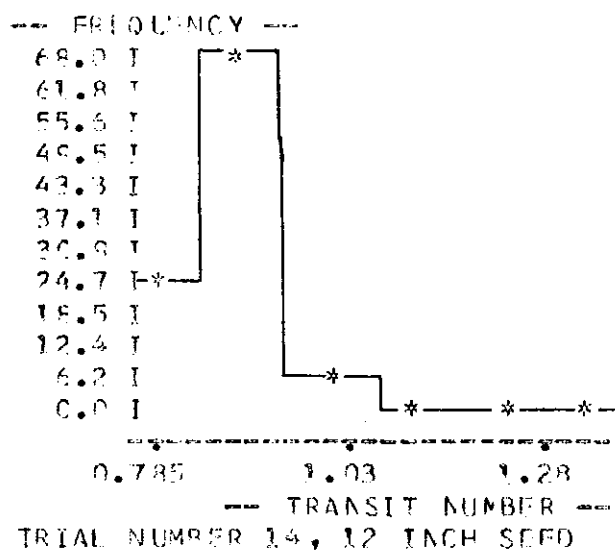
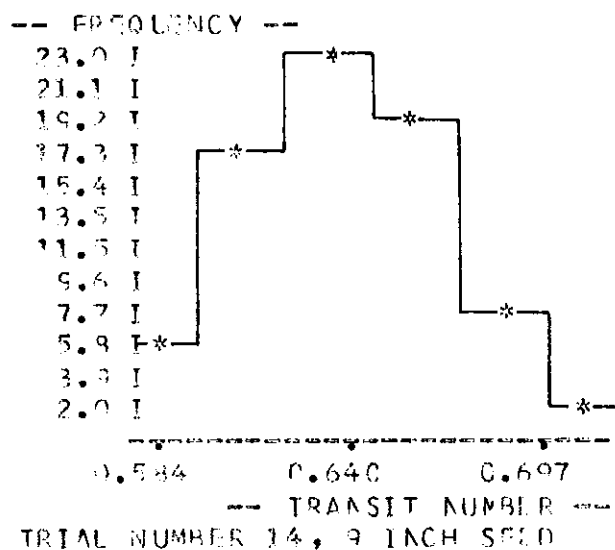
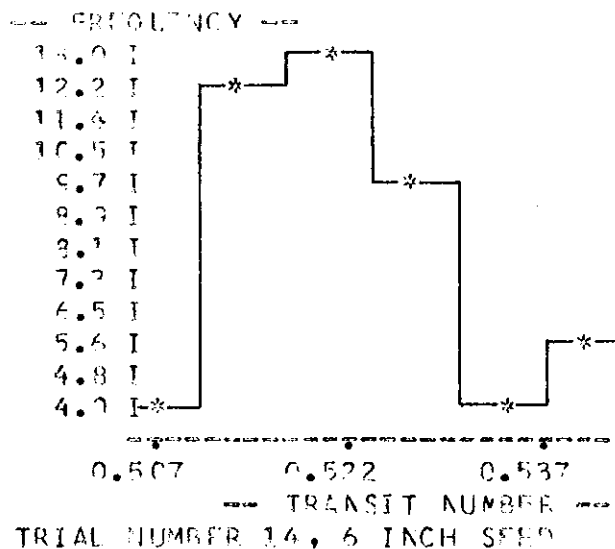
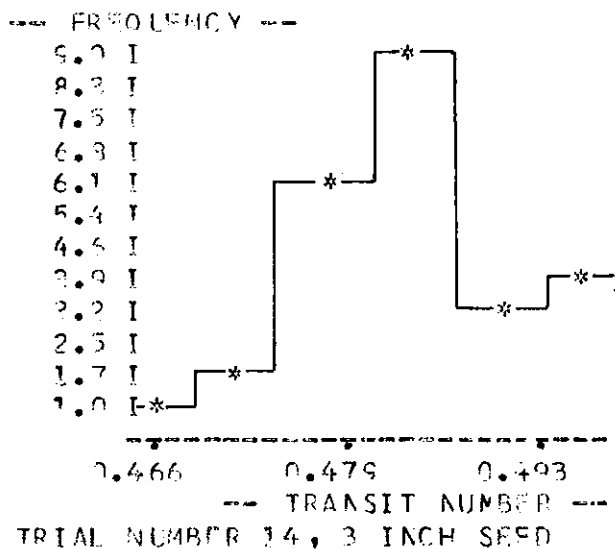

FIGURE 17

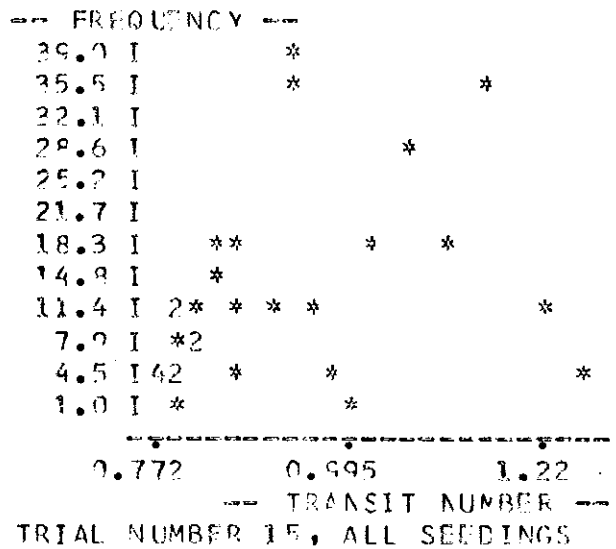
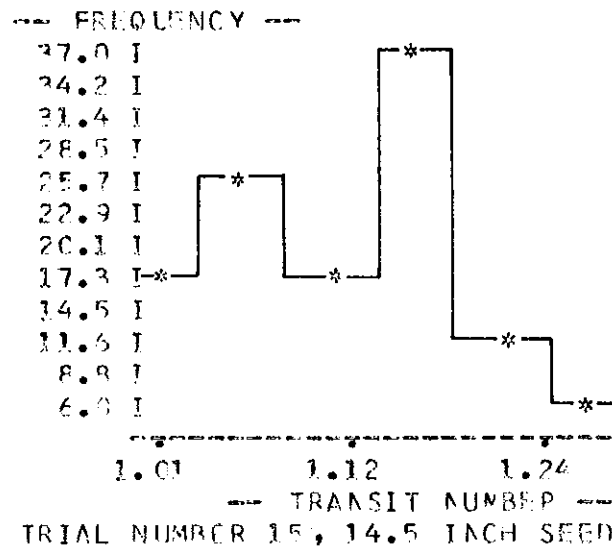
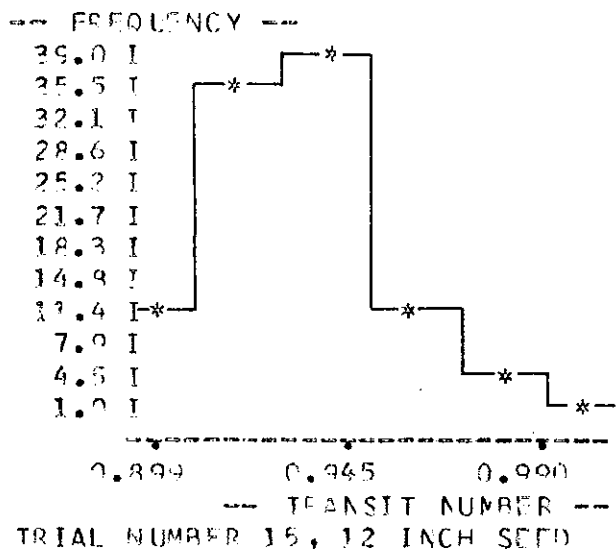
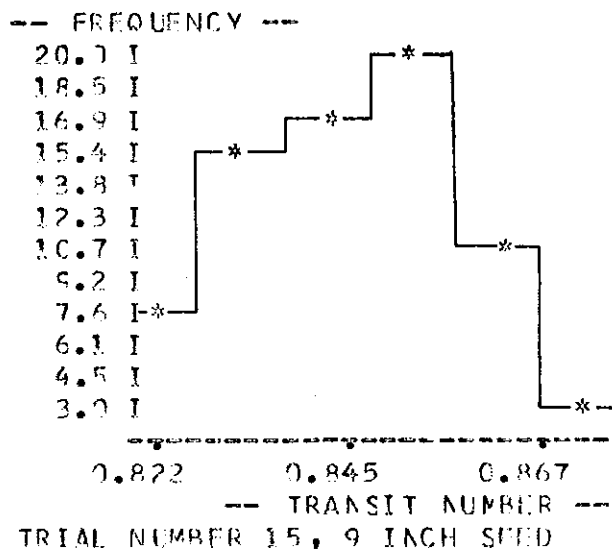
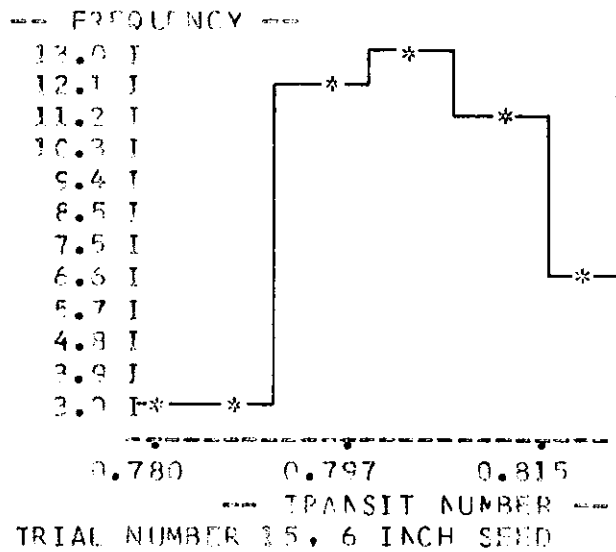
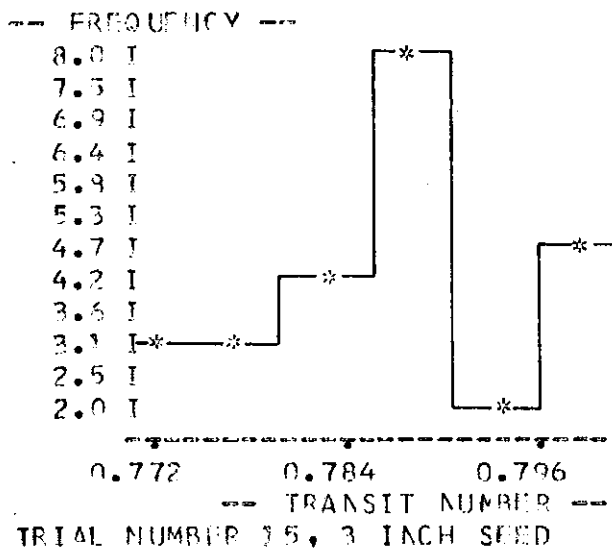

FIGURE 18

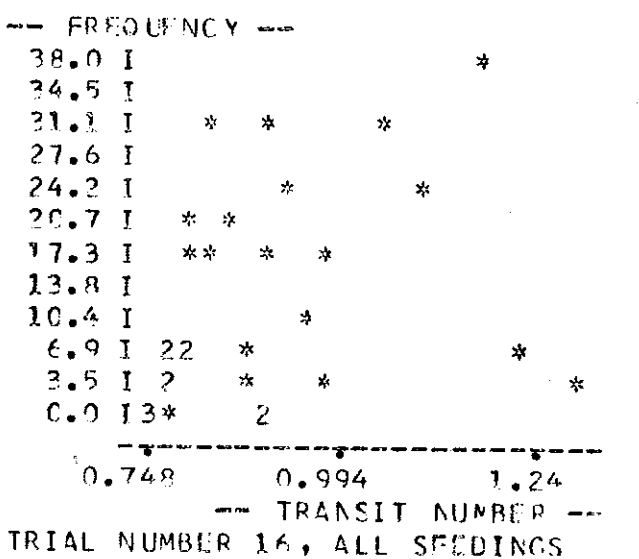
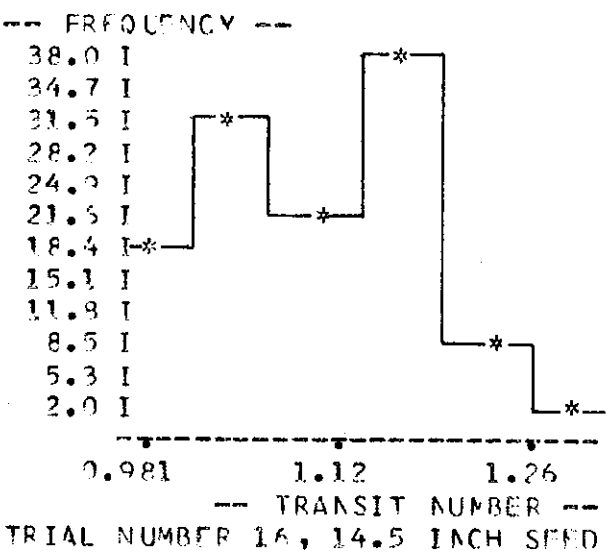
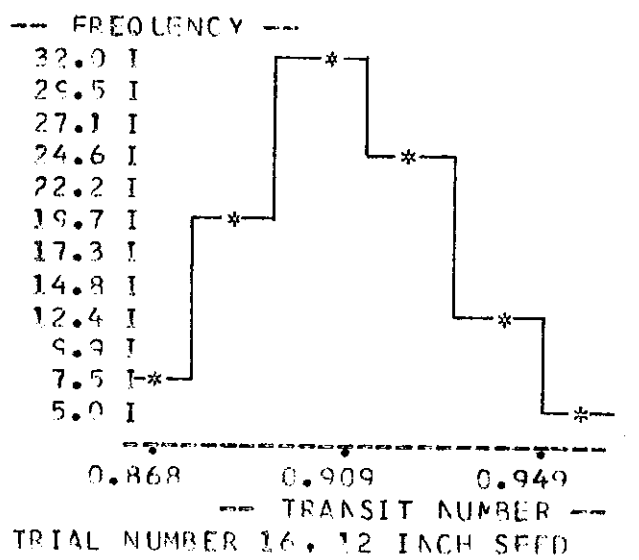
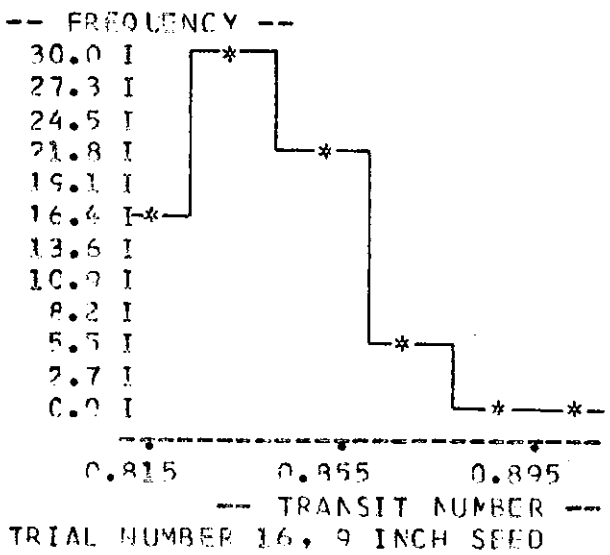
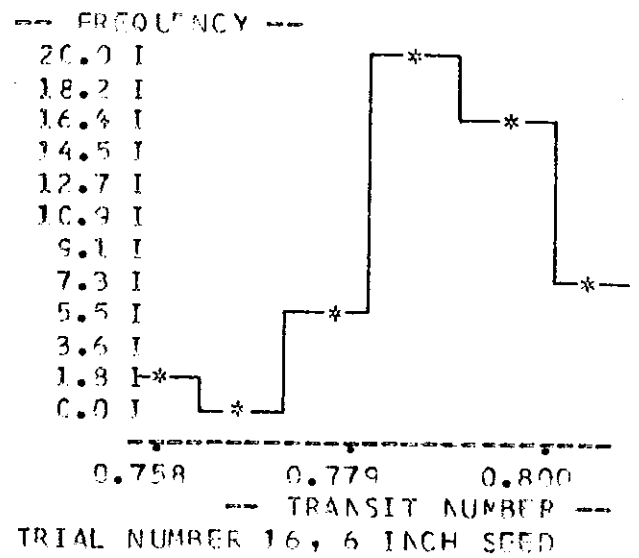
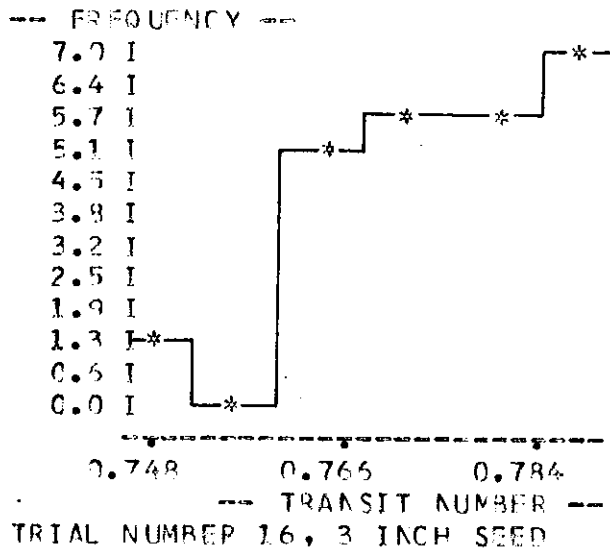

FIGURE 19

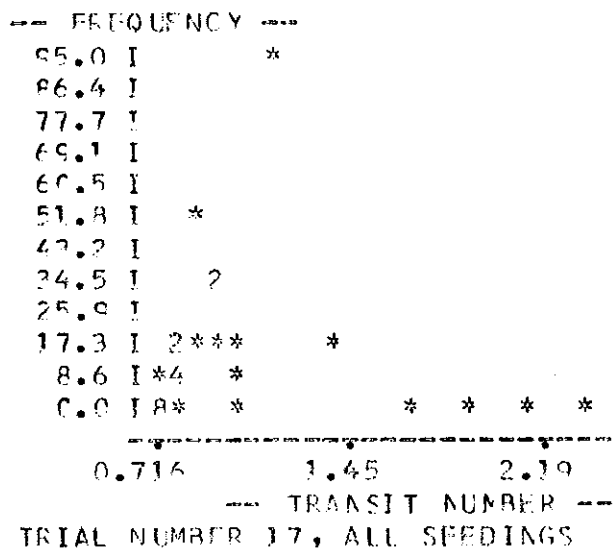
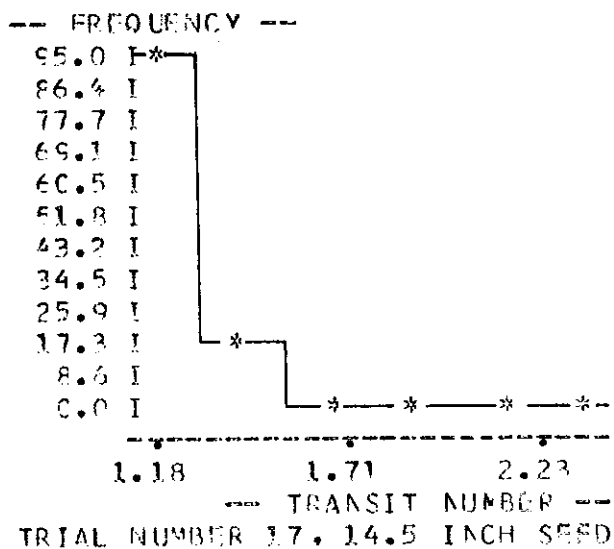
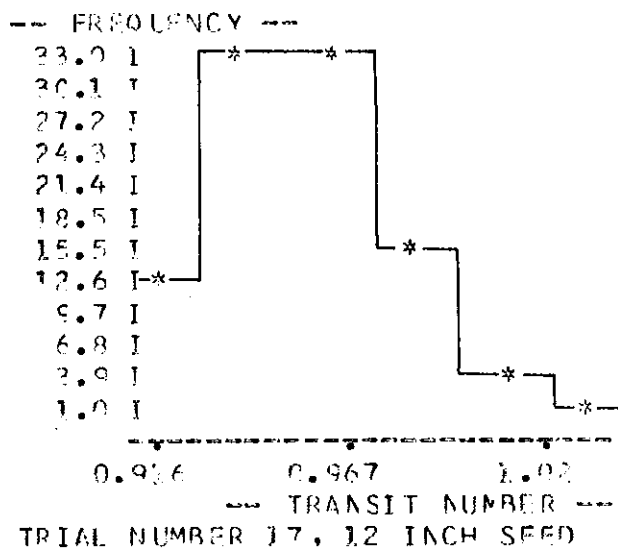
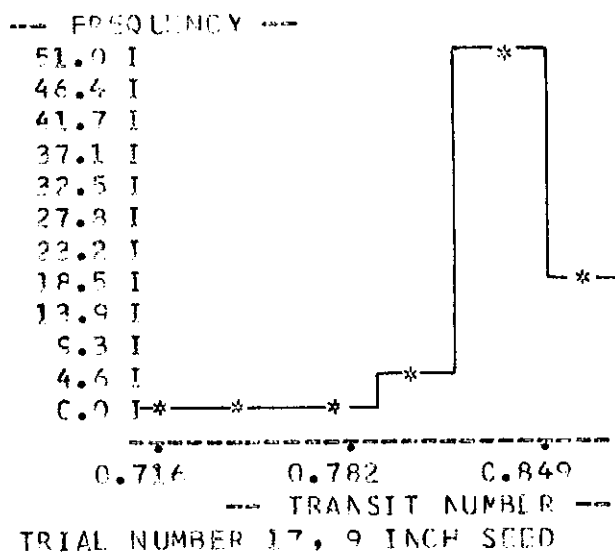
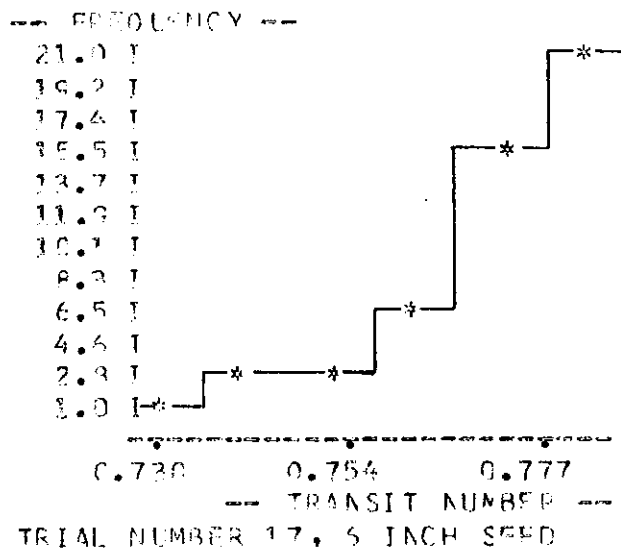
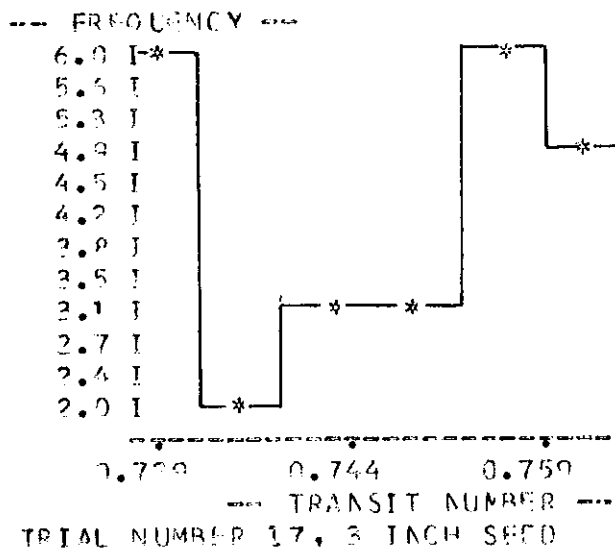
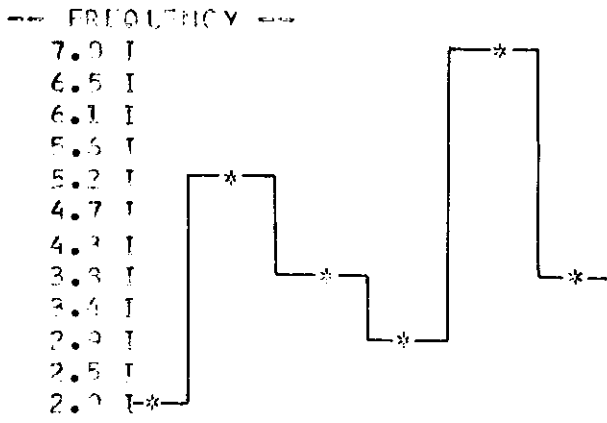
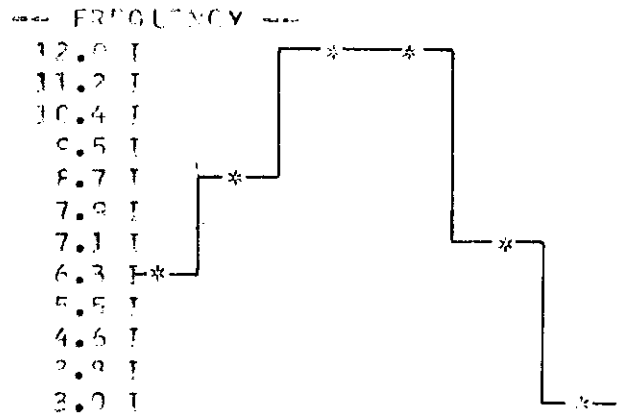

FIGURE 20



TRIAL NUMBER 18, 3 INCH SEED



TRIAL NUMBER 18, 6 INCH SEED

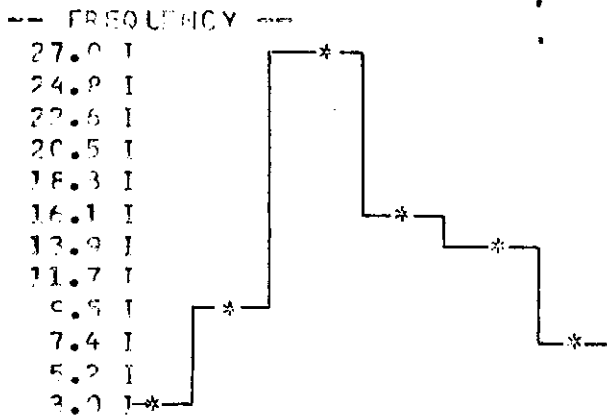

TRIAL NUMBER 18, 9 INCH SEED

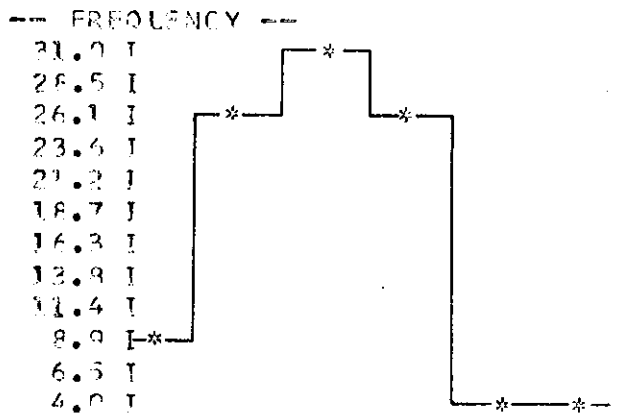

TRIAL NUMBER 18, 12 INCH SEED

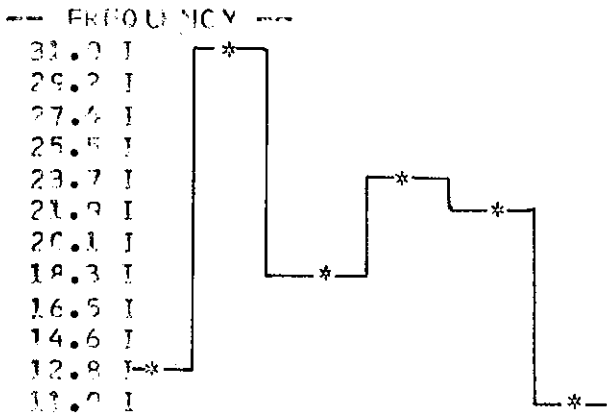

TRIAL NUMBER 18, 14.5 INCH SEED

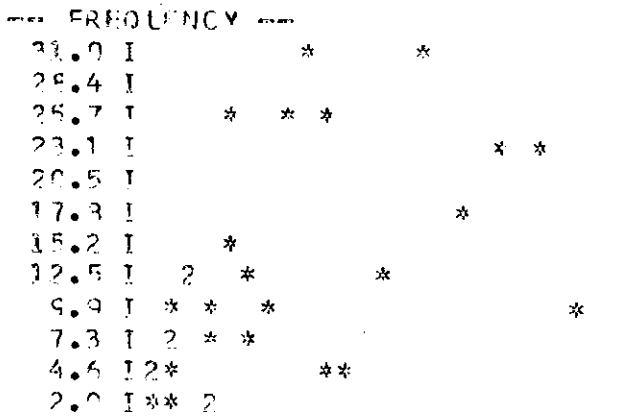

TRIAL NUMBER 18, ALL SEEDING

FIGURE 21

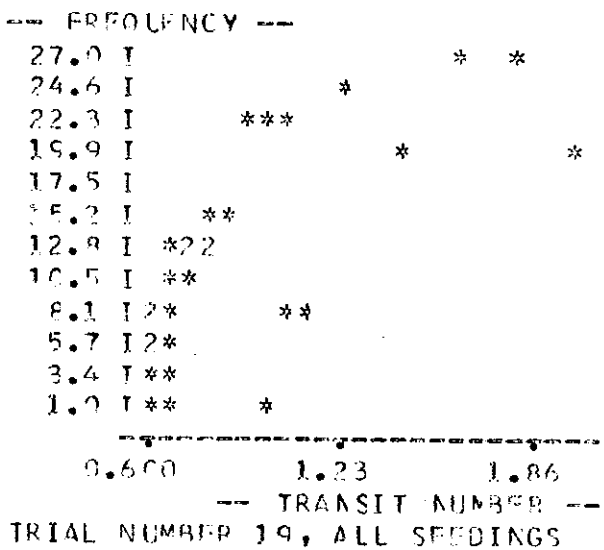
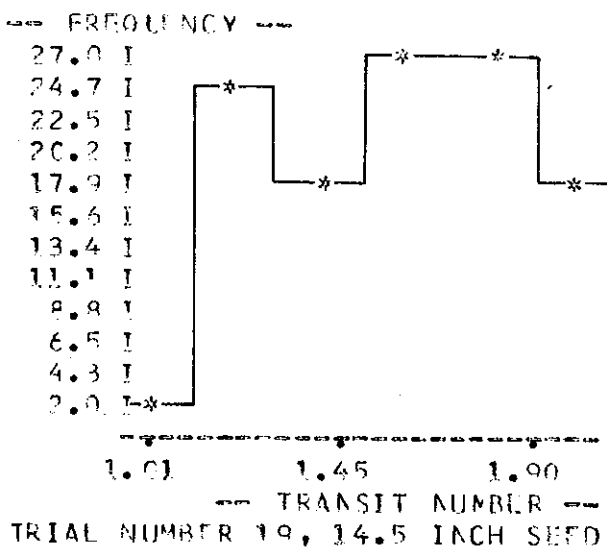
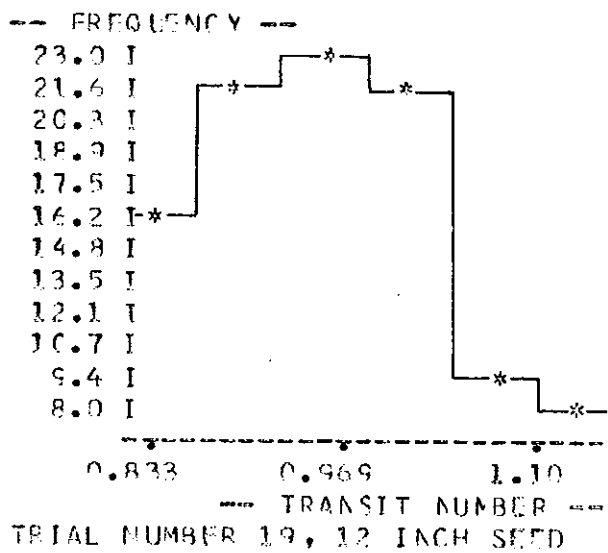
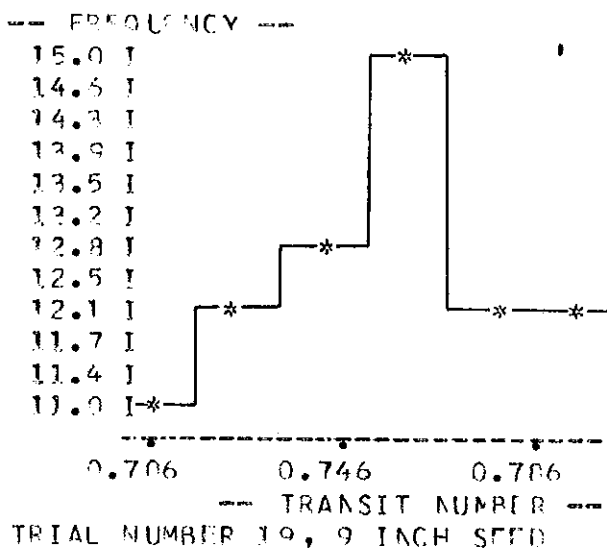
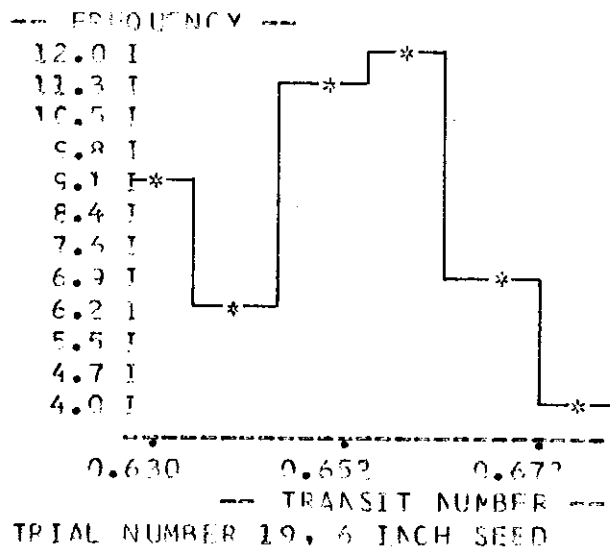
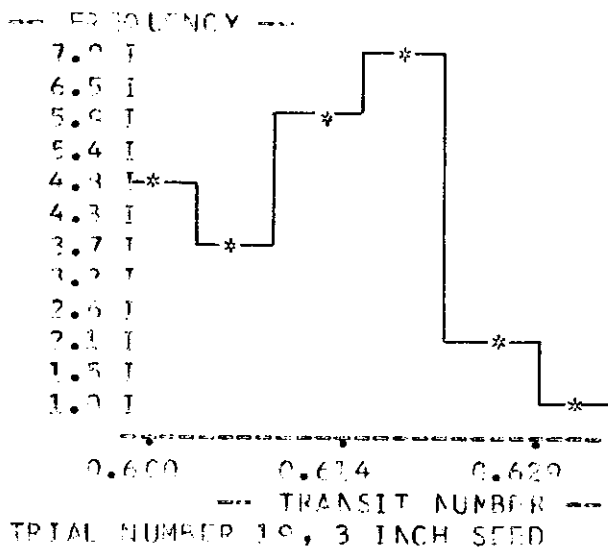

FIGURE 22

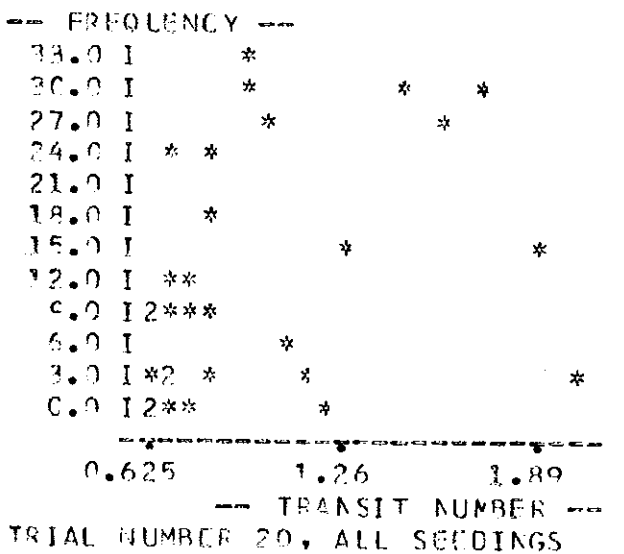
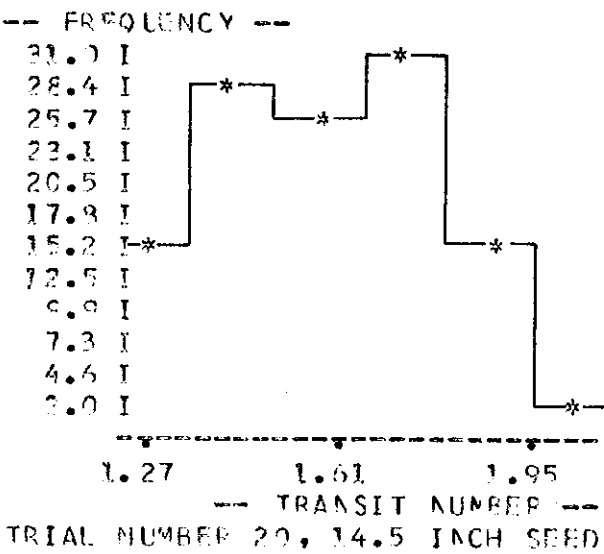
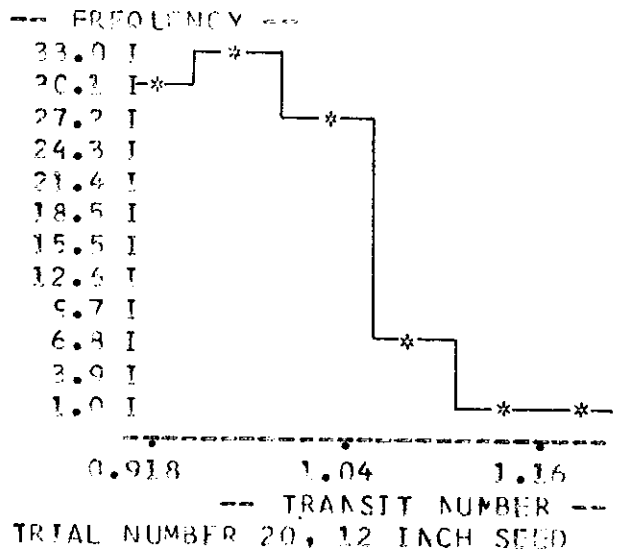
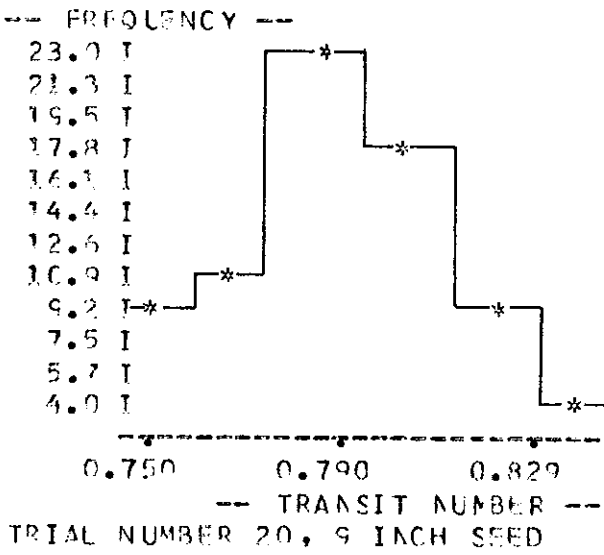
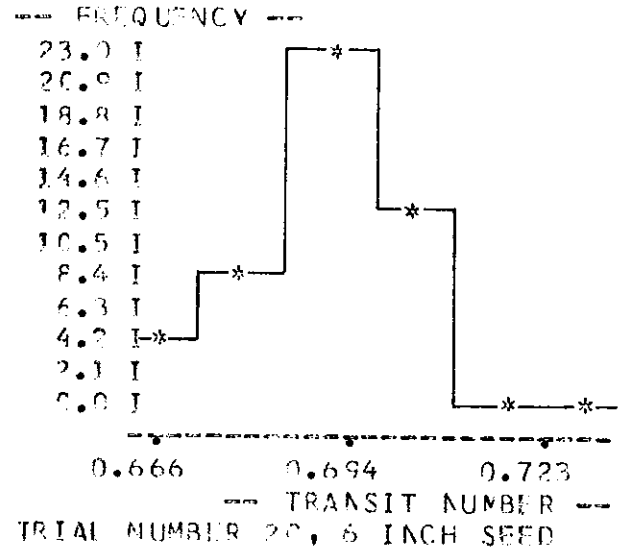
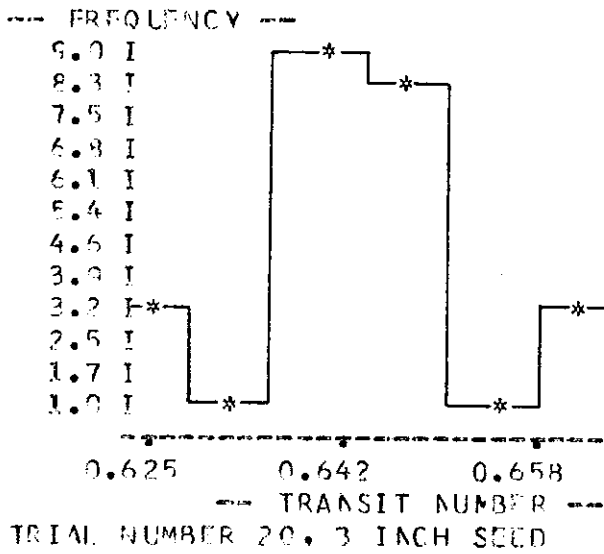

FIGURE 23

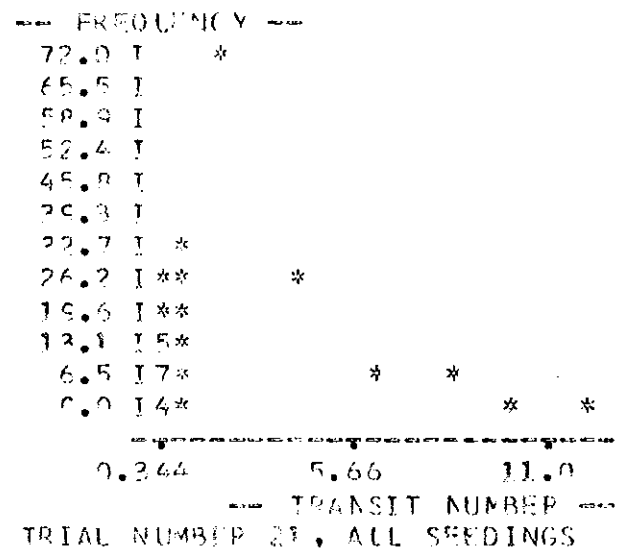
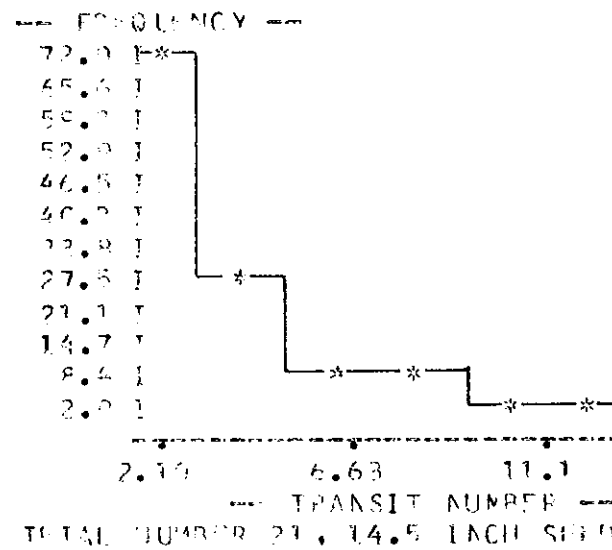
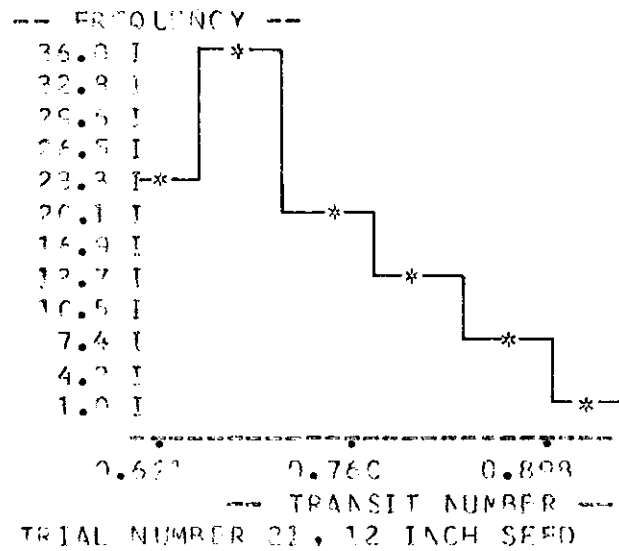
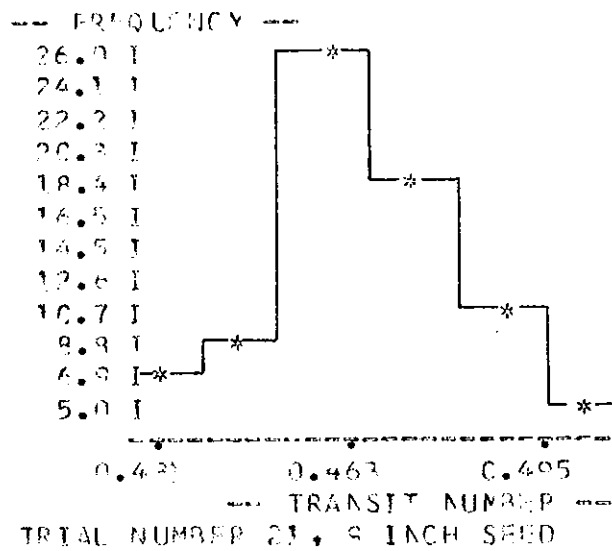
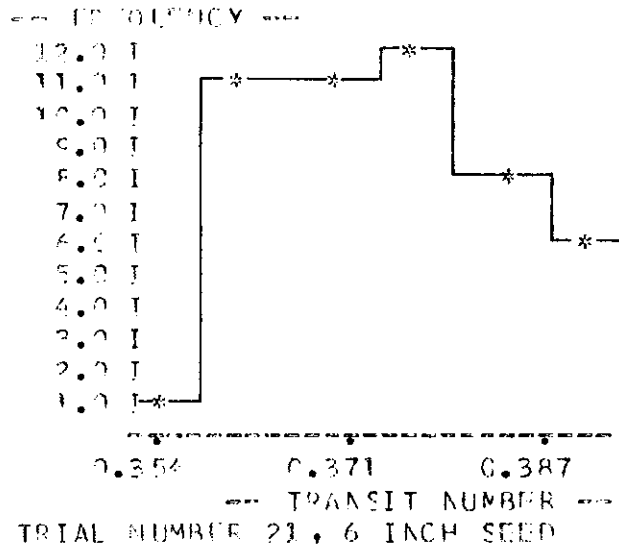
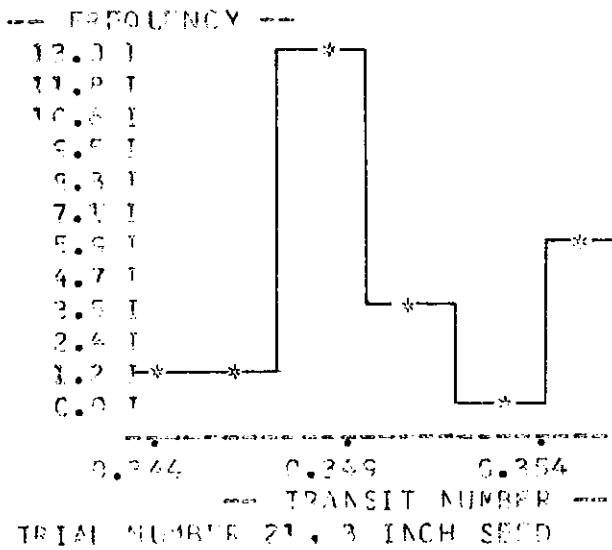

FIGURE 24

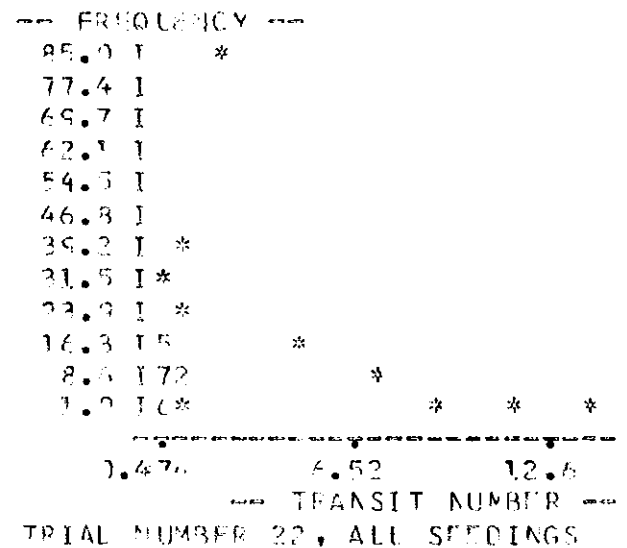
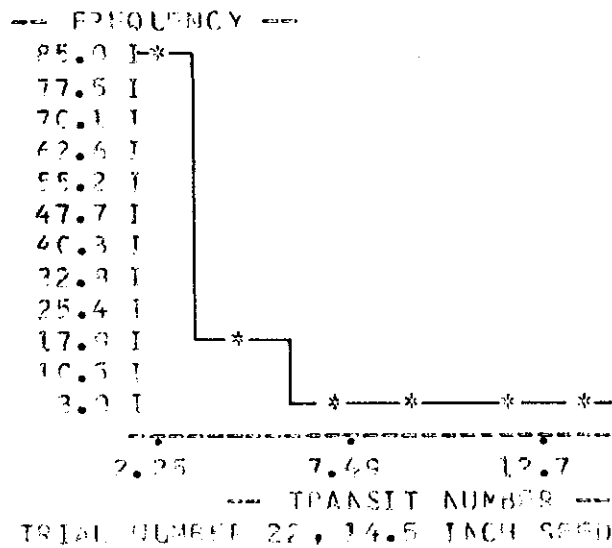
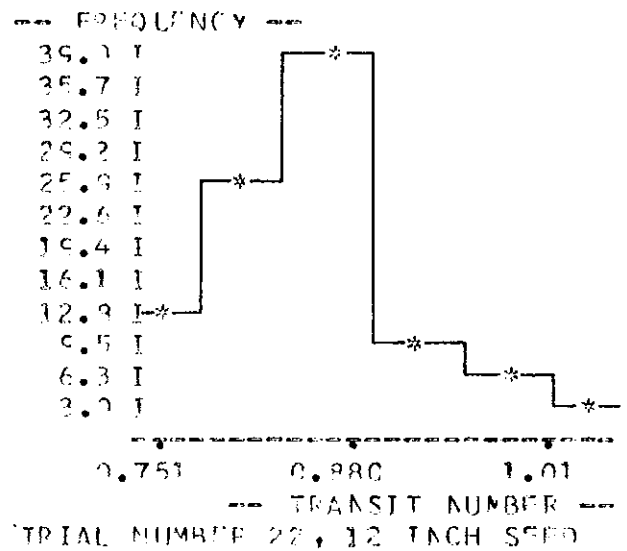
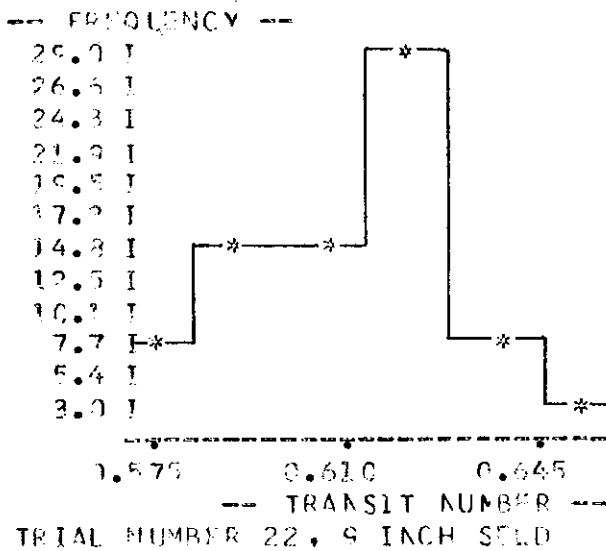
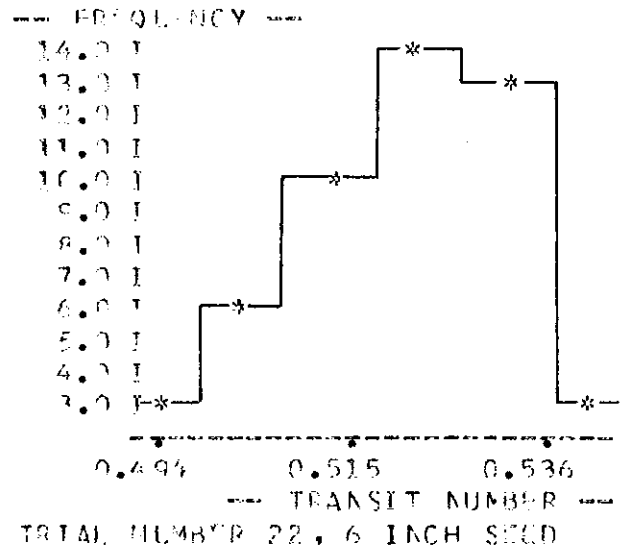
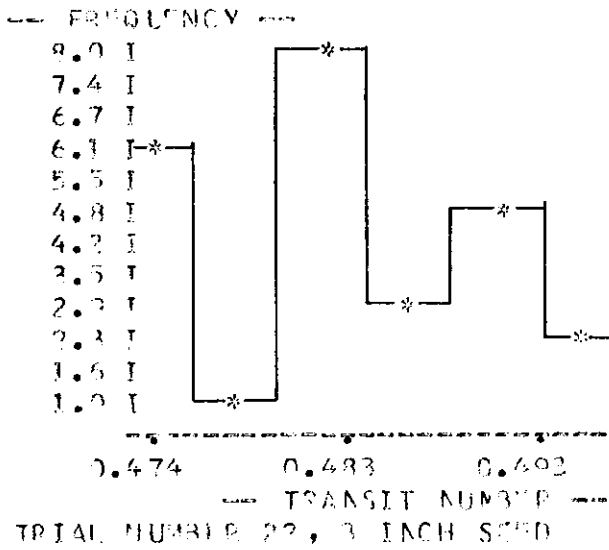
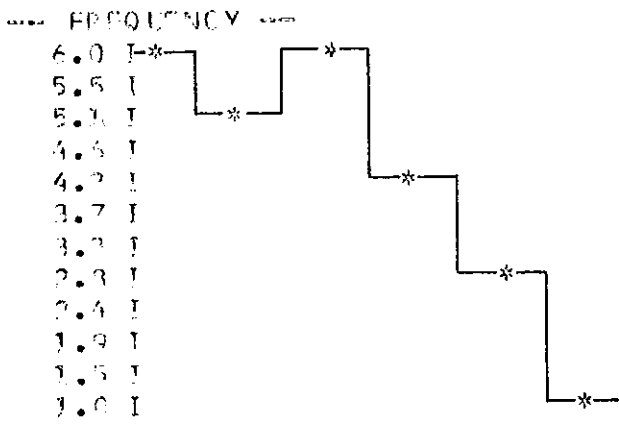
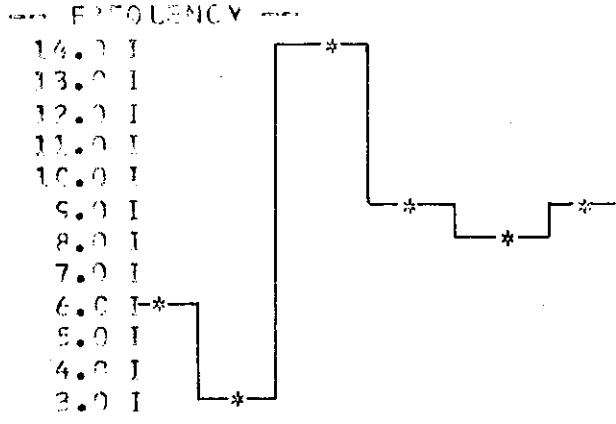

FIGURE 25



0.854 0.865 0.877  
 --- TRANSIT NUMBER ---  
 TRIAL NUMBER 23, 3 INCH SEED



0.855 0.872 0.889  
 --- TRANSIT NUMBER ---  
 TRIAL NUMBER 23, 6 INCH SEED

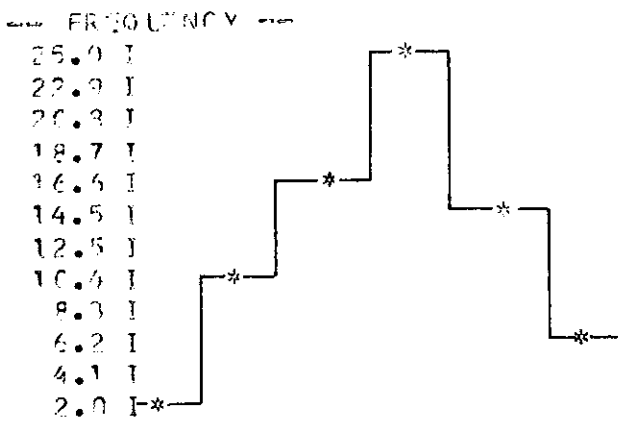

0.880 0.913 0.946  
 --- TRANSIT NUMBER ---  
 TRIAL NUMBER 23, 9 INCH SEED

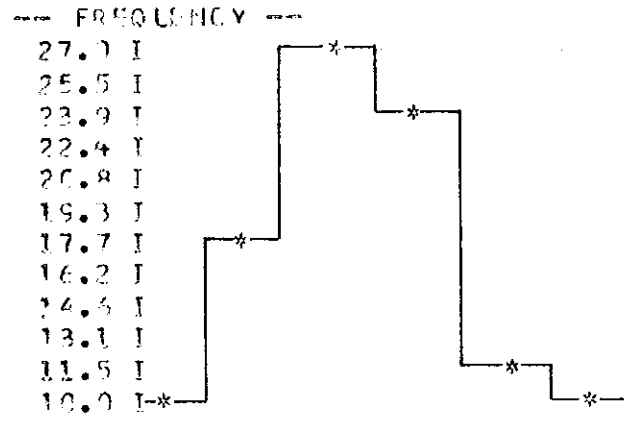

0.966 0.997 1.03  
 --- TRANSIT NUMBER ---  
 TRIAL NUMBER 23, 12 INCH SEED

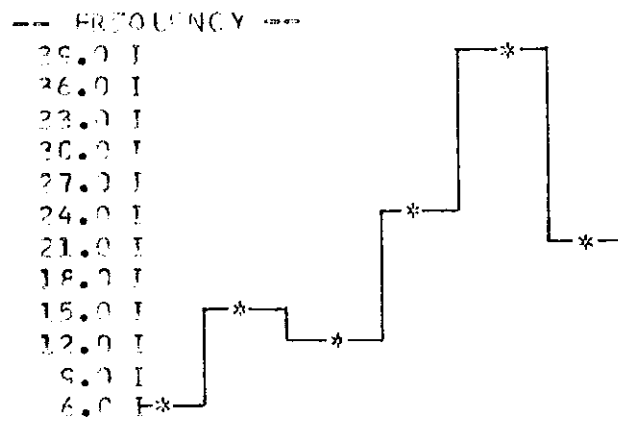

1.00 1.14 1.20  
 --- TRANSIT NUMBER ---  
 TRIAL NUMBER 23, 14.5 INCH SEED

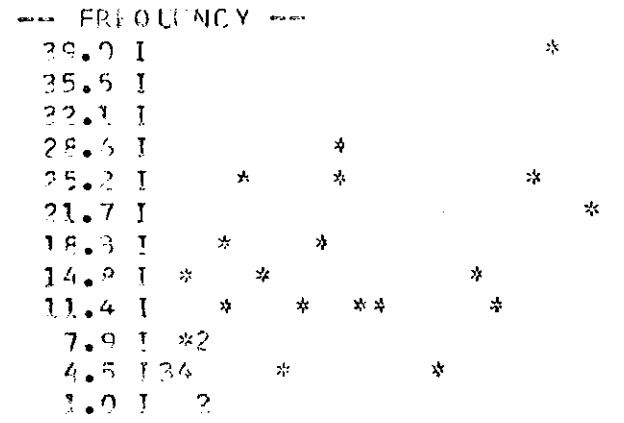

0.854 1.00 1.19  
 --- TRANSIT NUMBER ---  
 TRIAL NUMBER 23, ALL SEEDLINGS

FIGURE 26

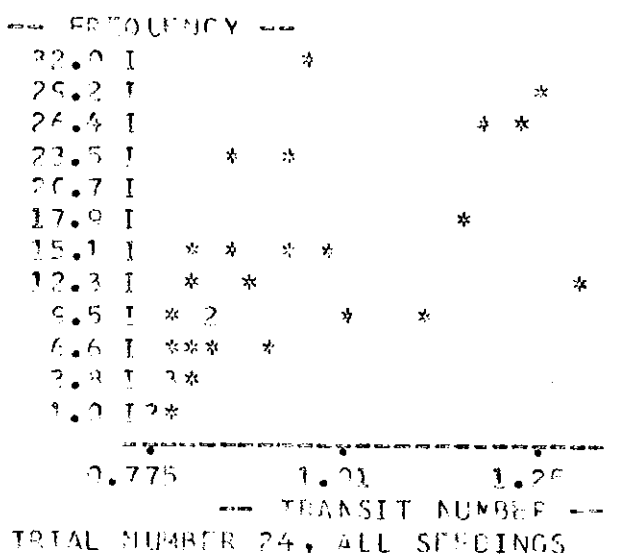
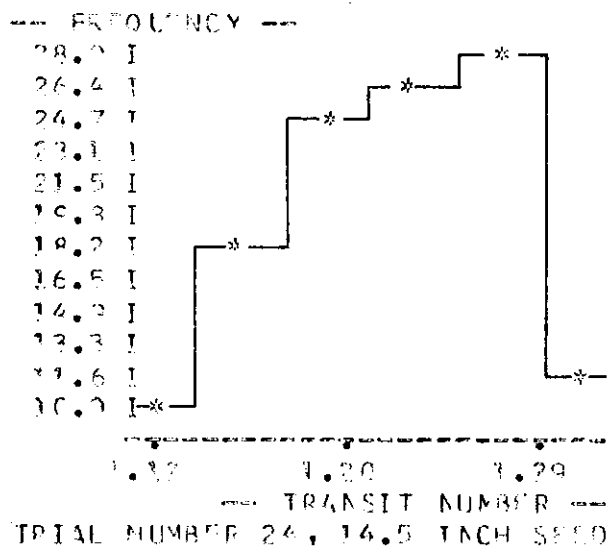
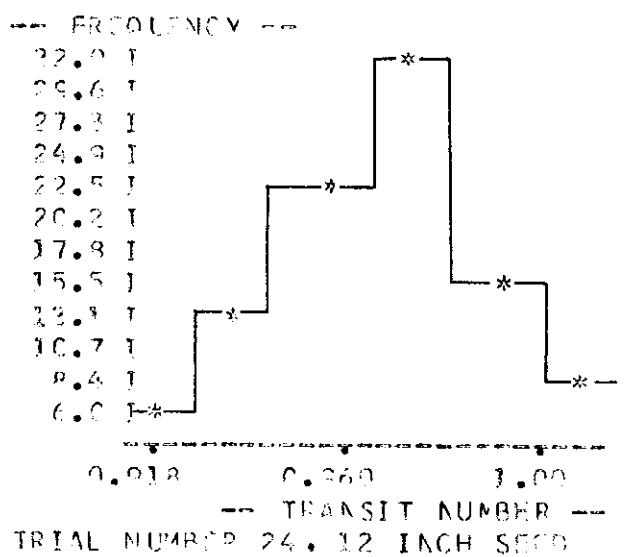
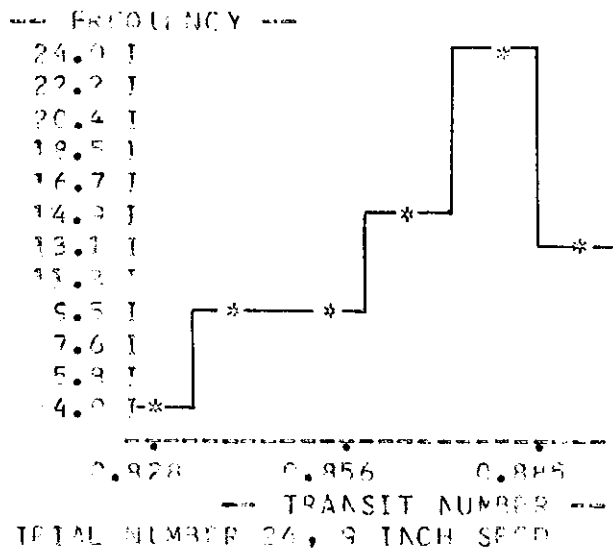
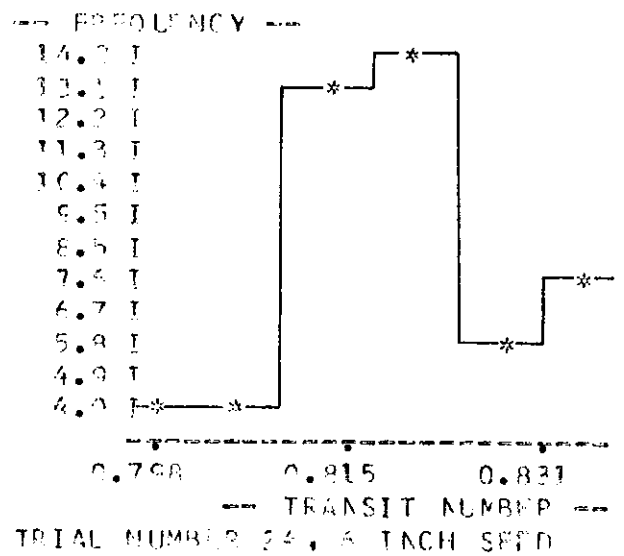
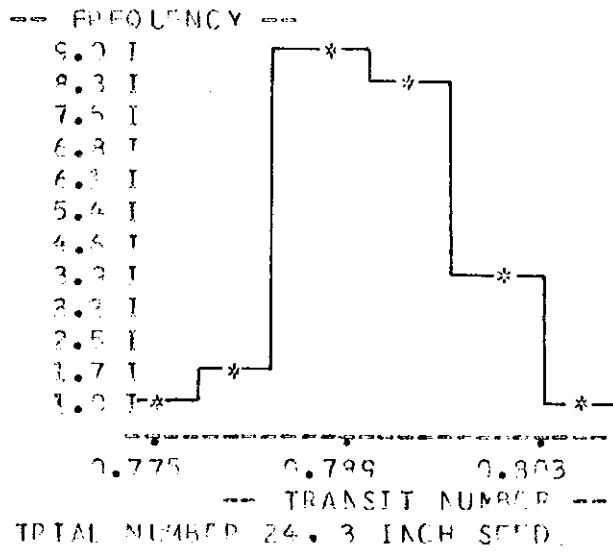

FIGURE 27.

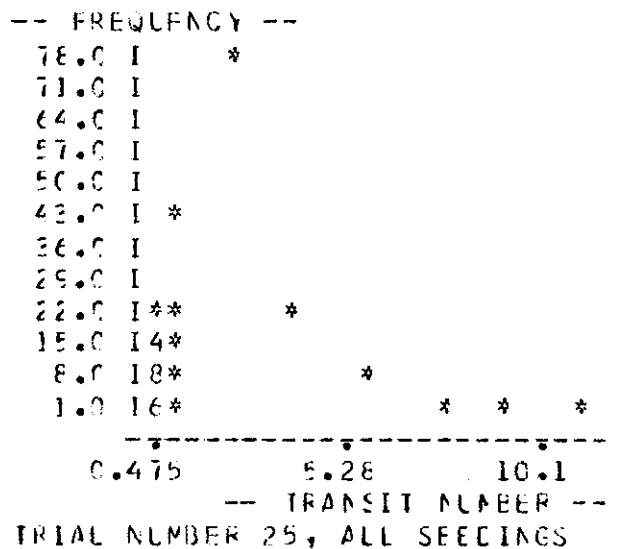
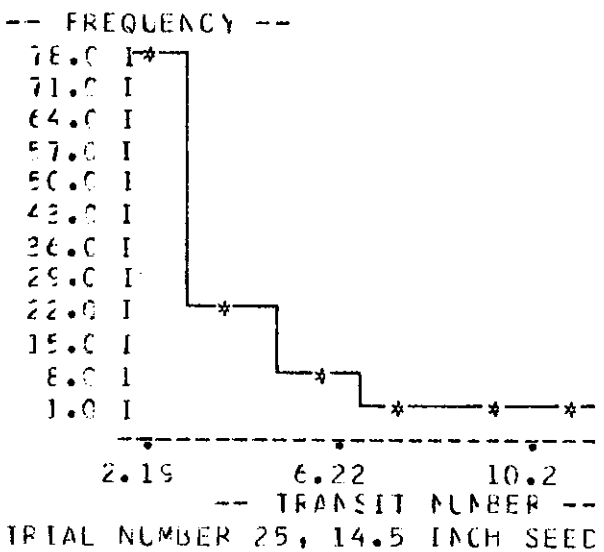
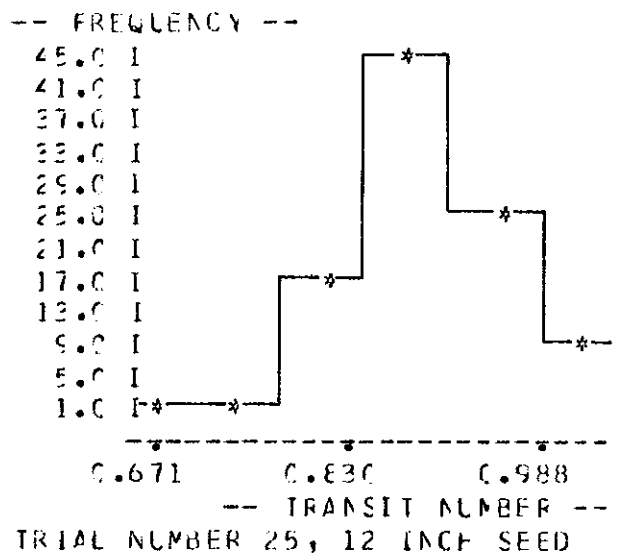
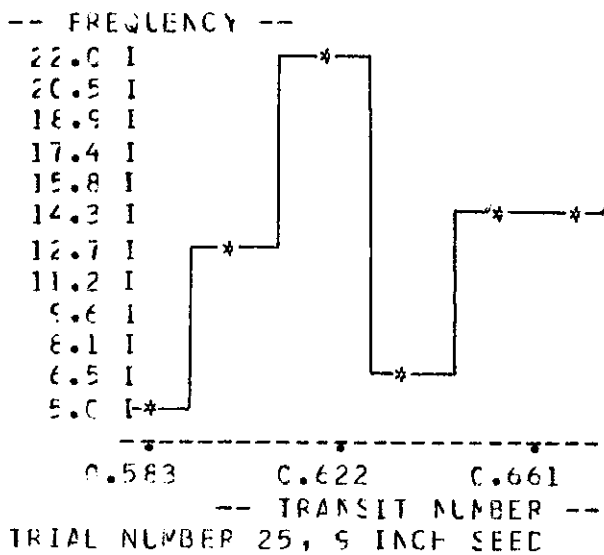
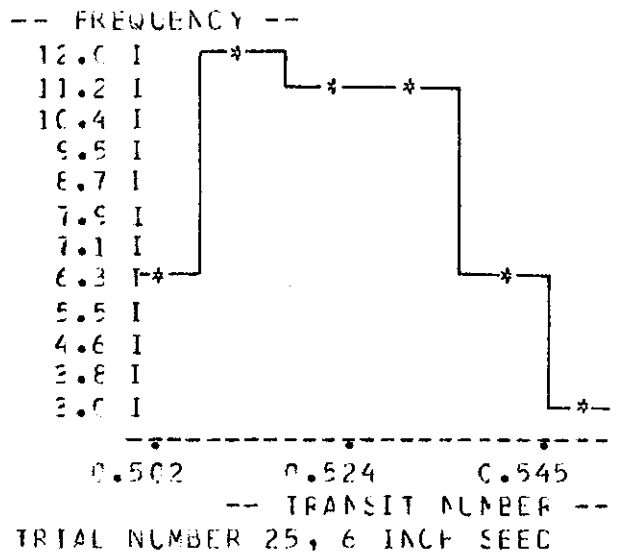
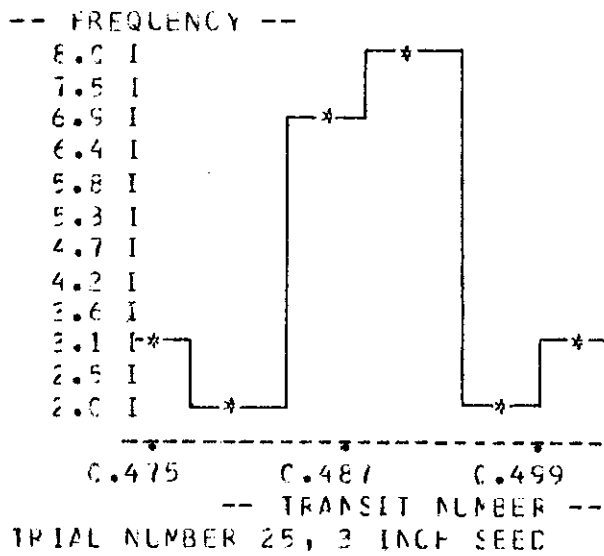

FIGURE 28

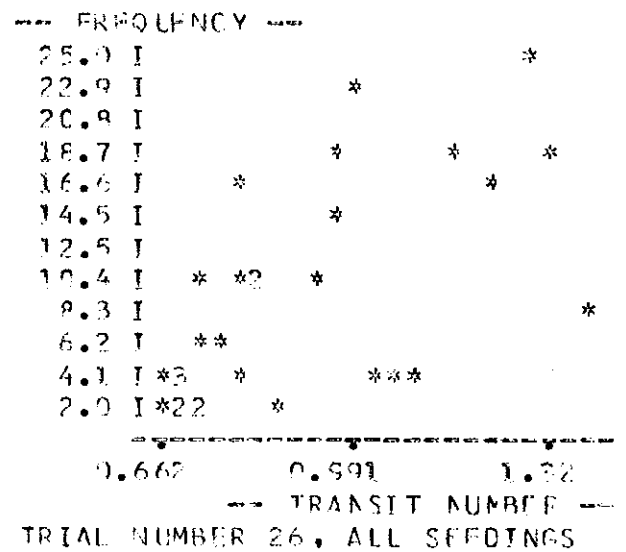
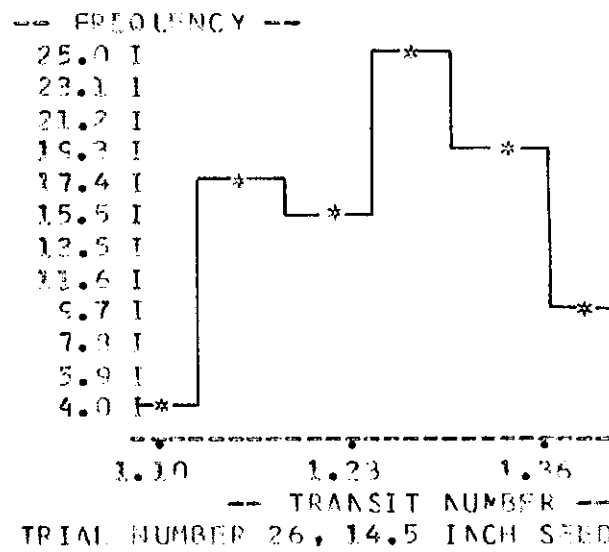
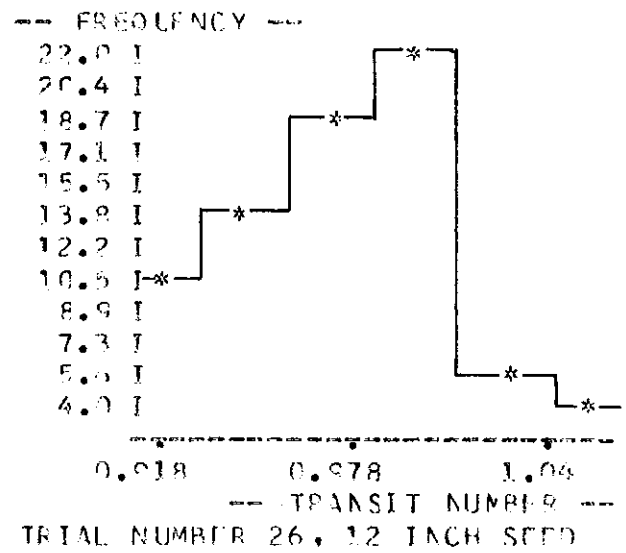
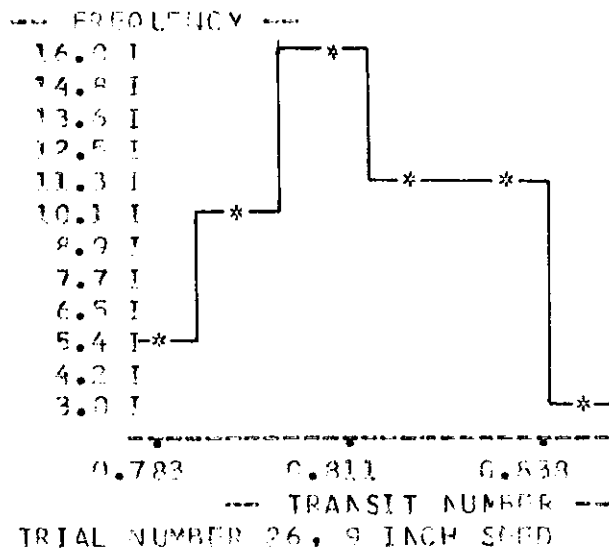
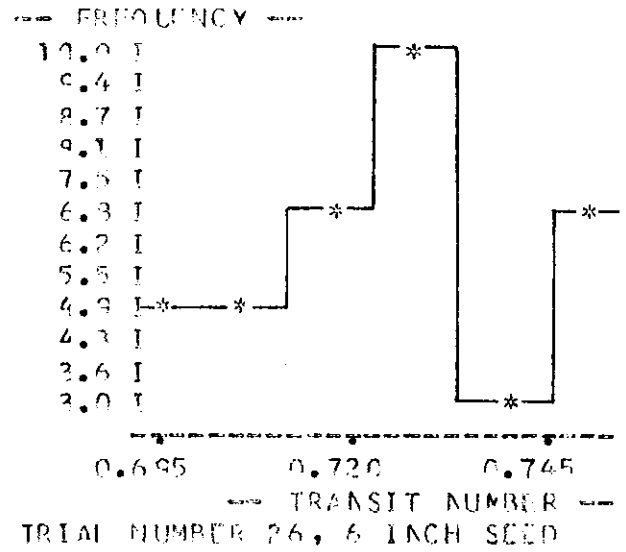
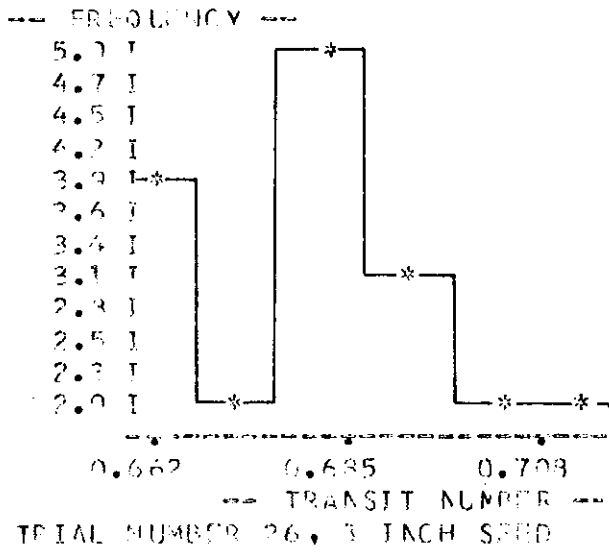

FIGURE 29

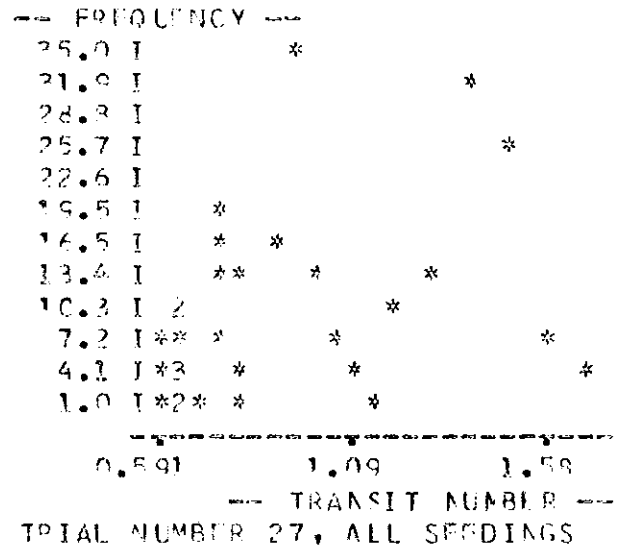
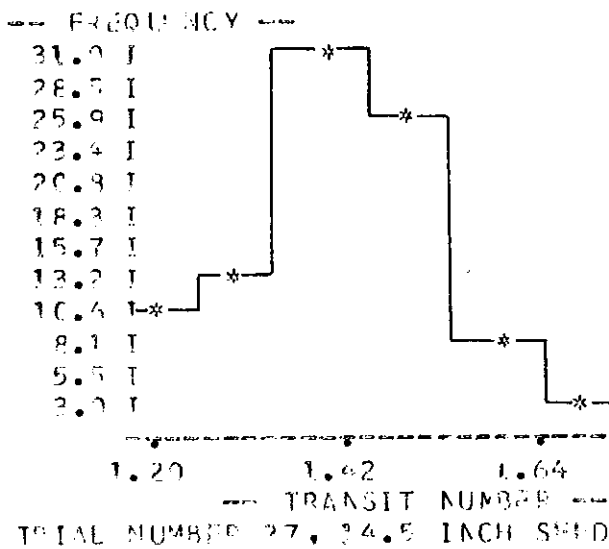
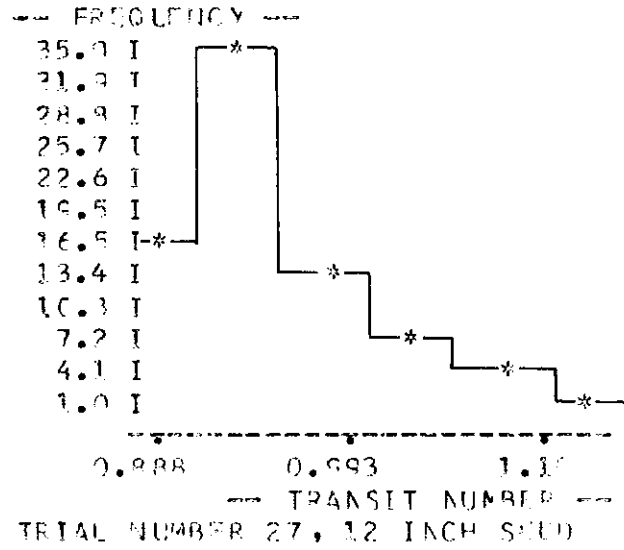
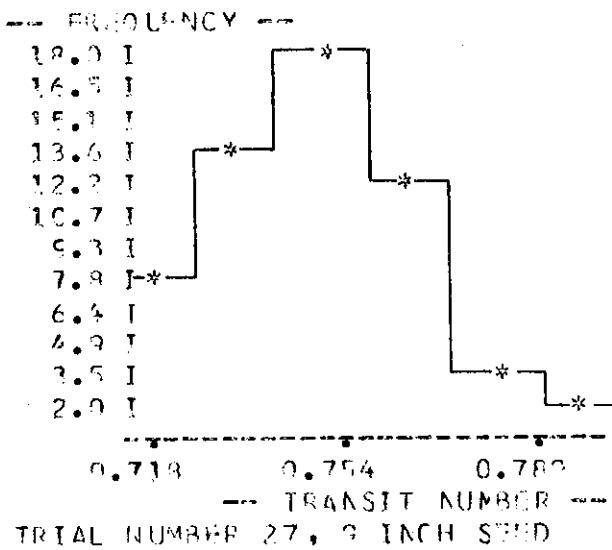
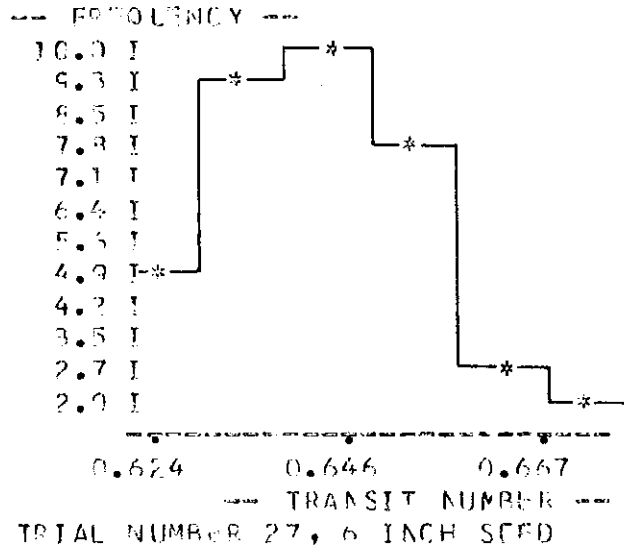
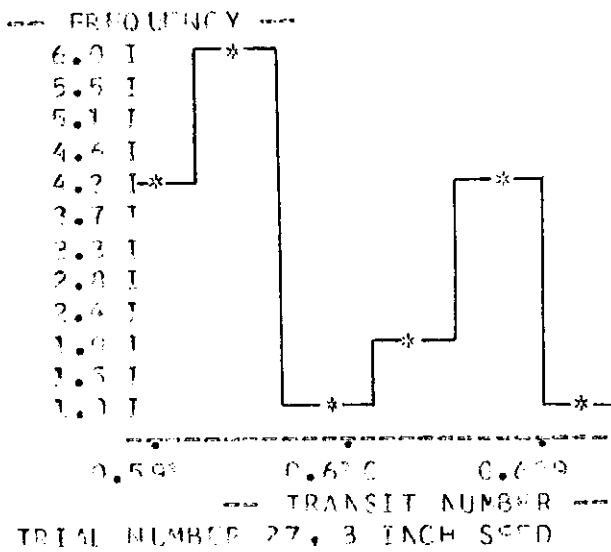

FIGURE 30

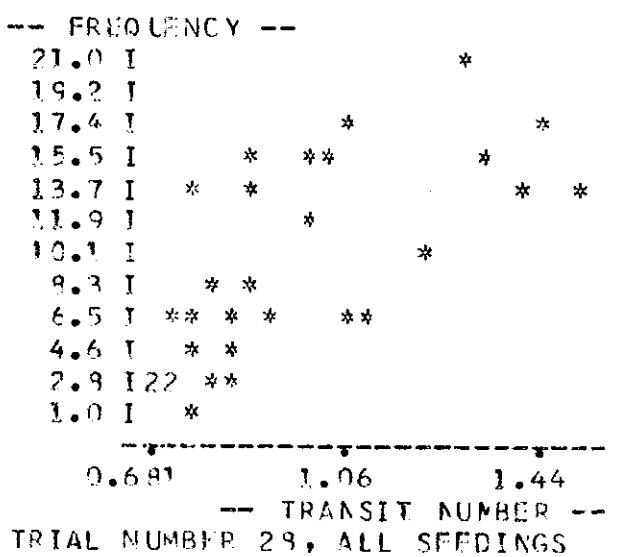
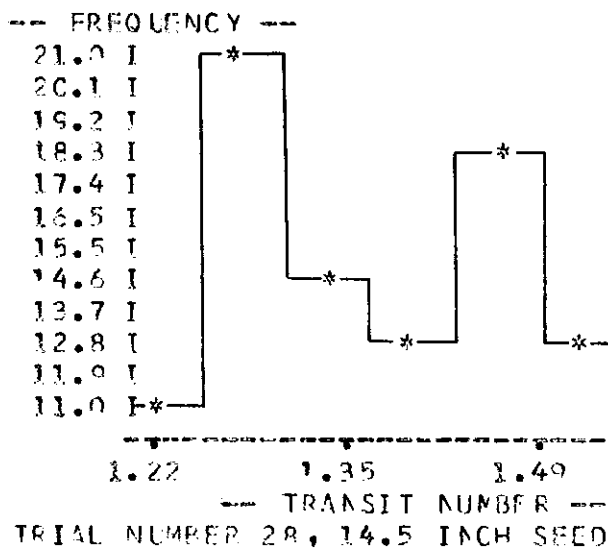
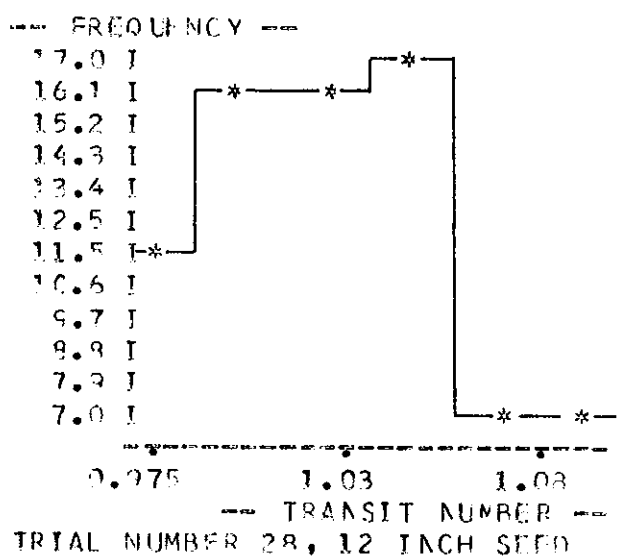
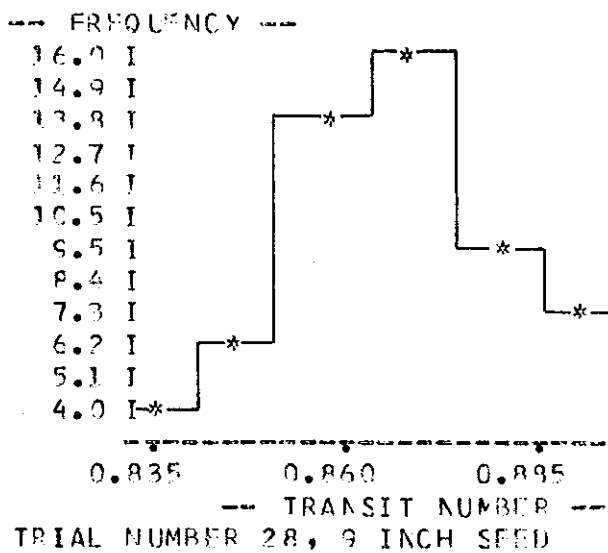
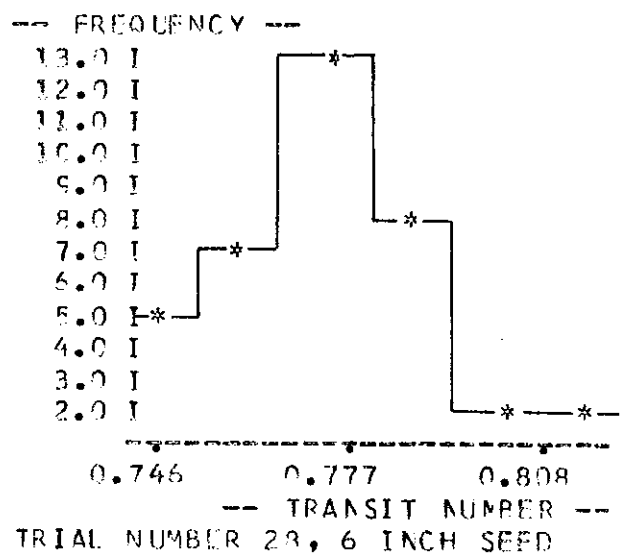
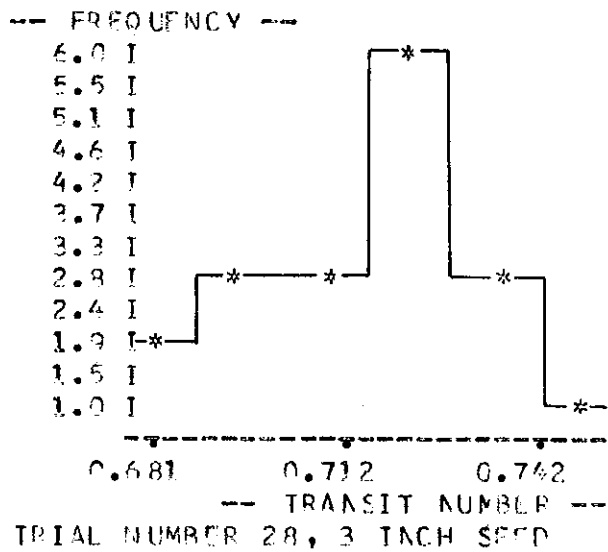

FIGURE 31

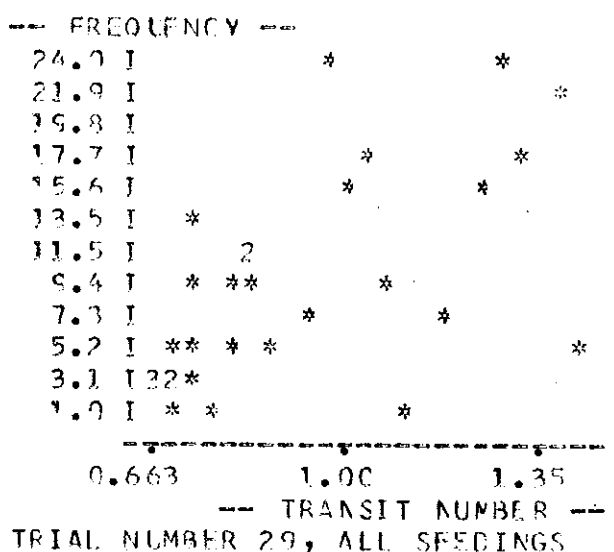
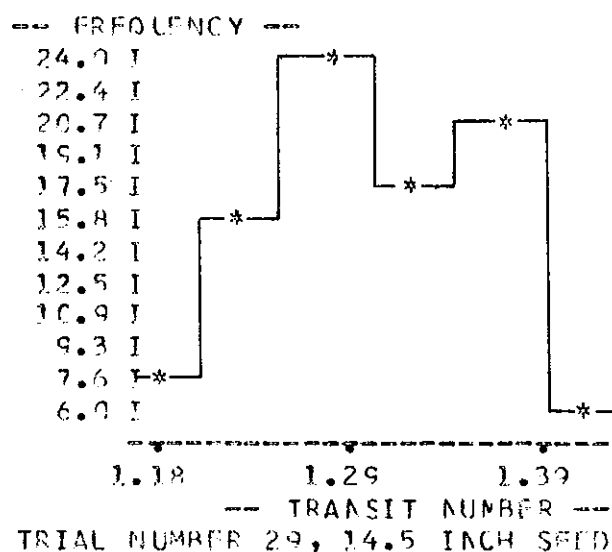
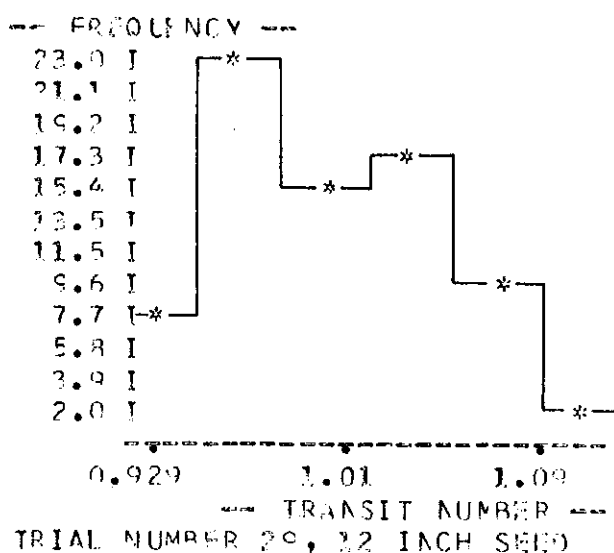
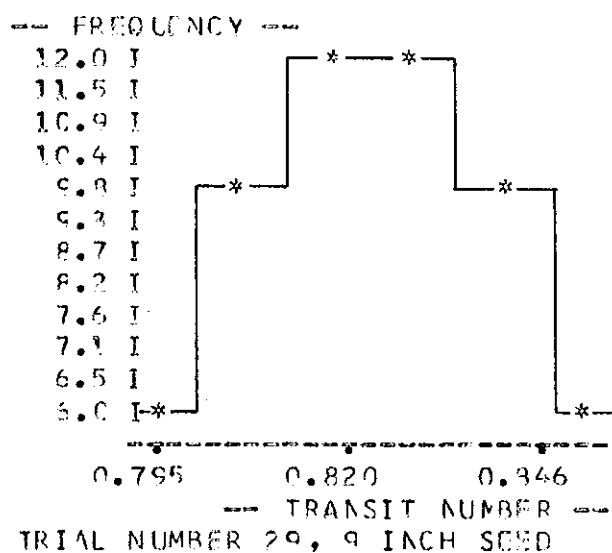
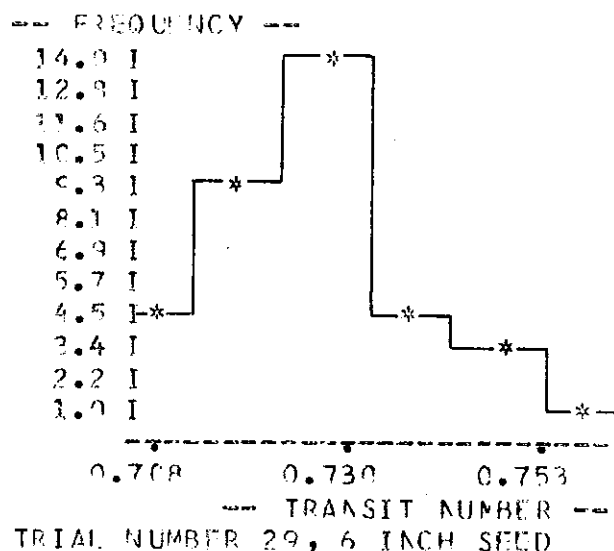
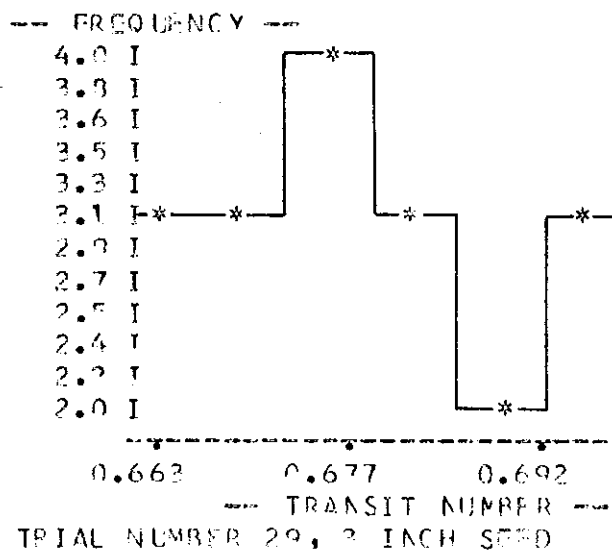

FIGURE 32

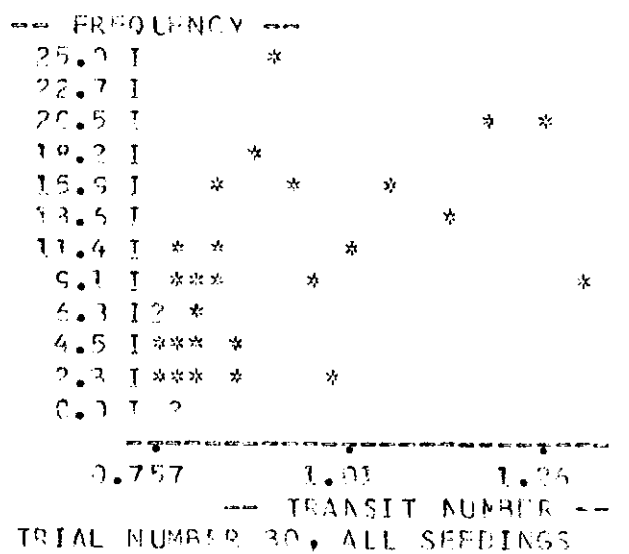
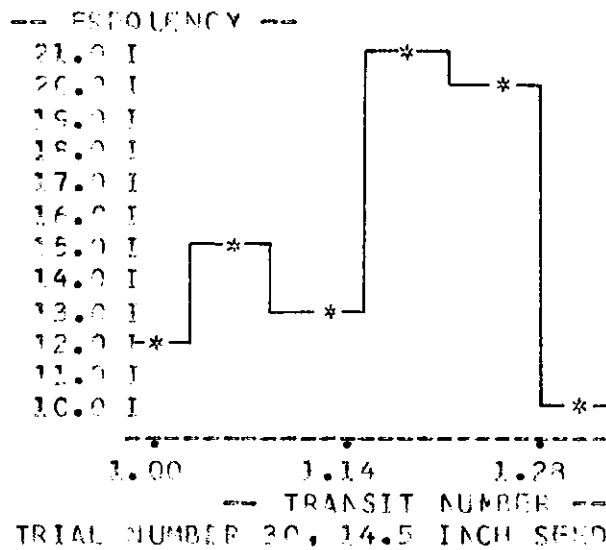
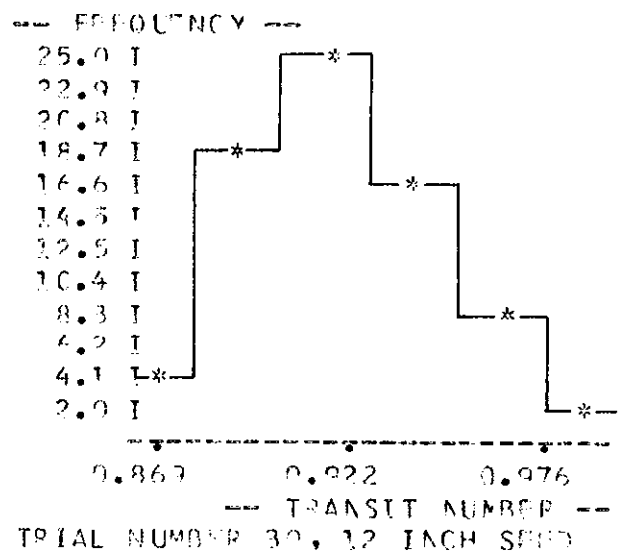
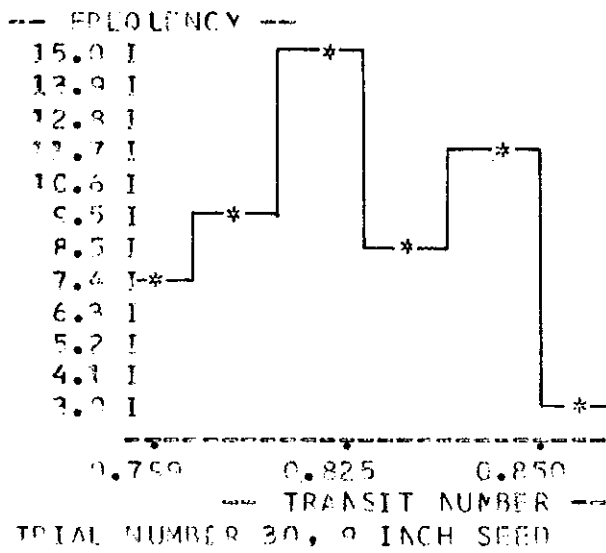
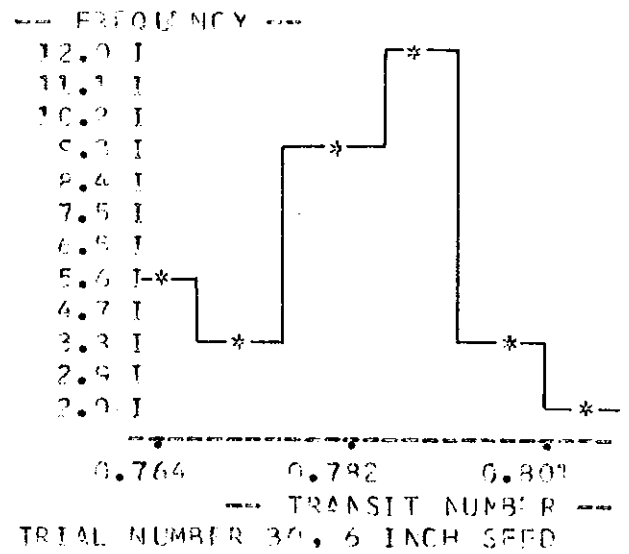
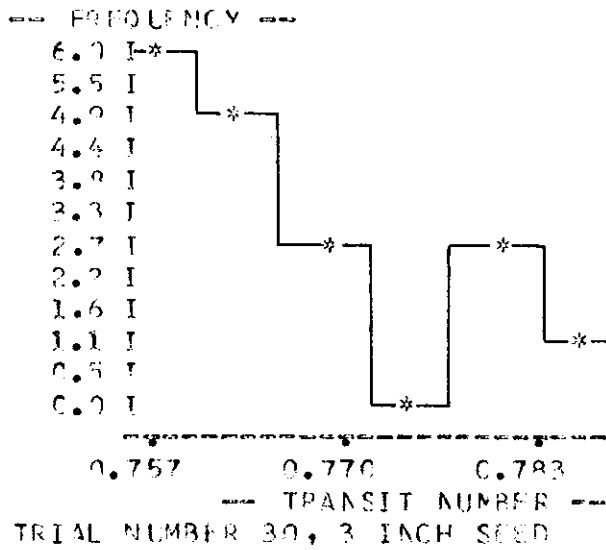

FIGURE 33

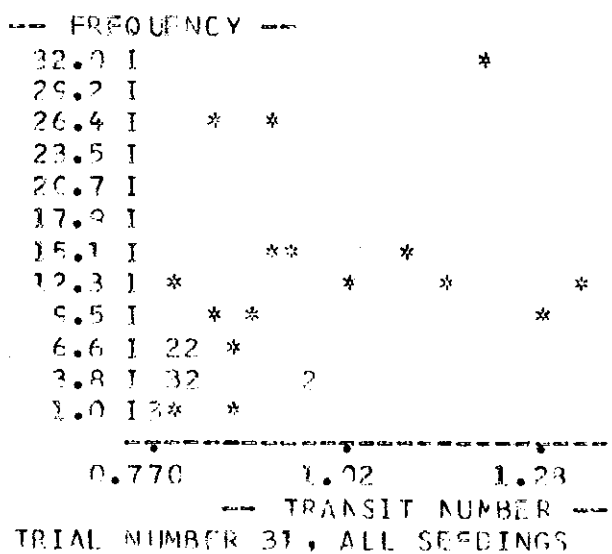
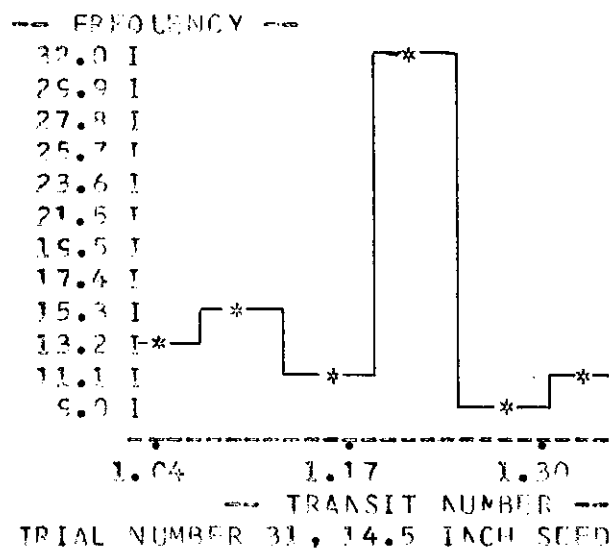
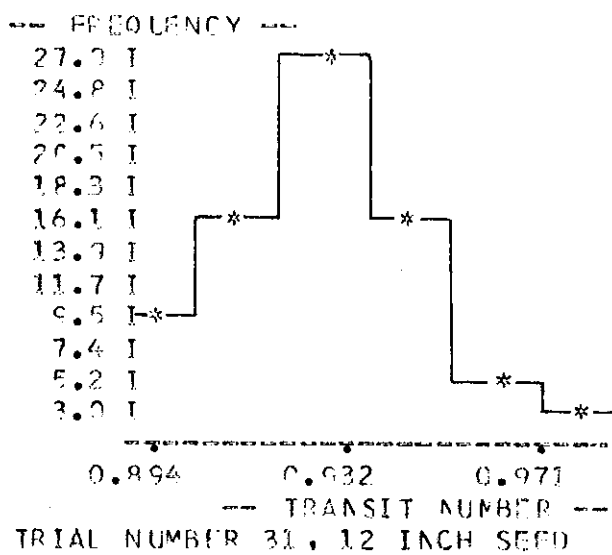
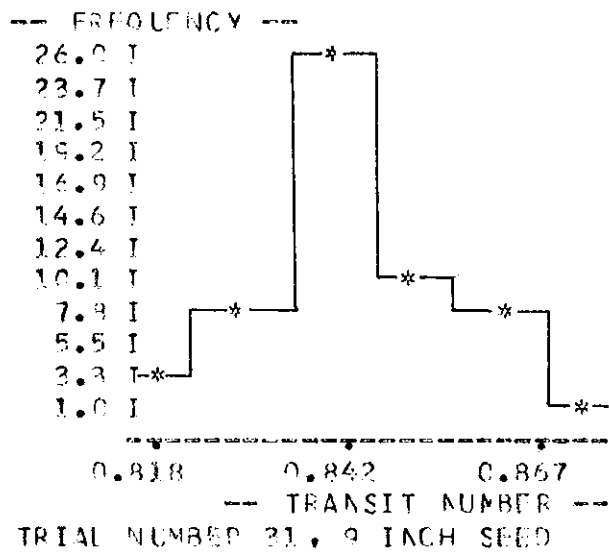
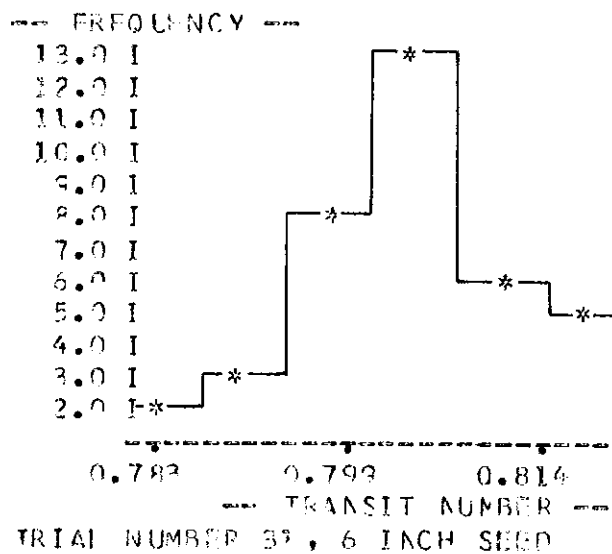
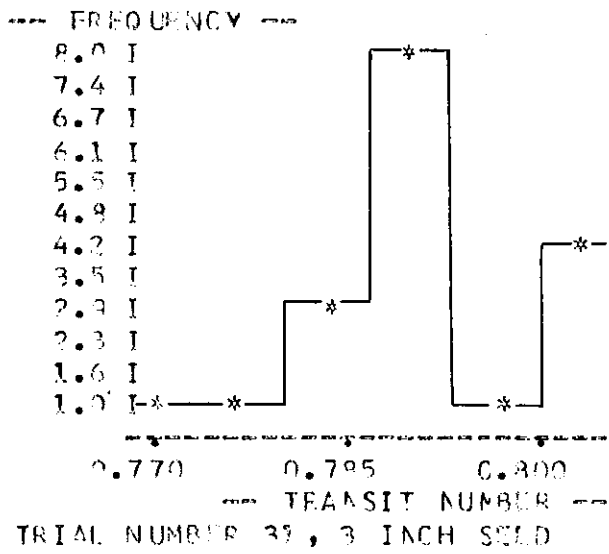

FIGURE 34

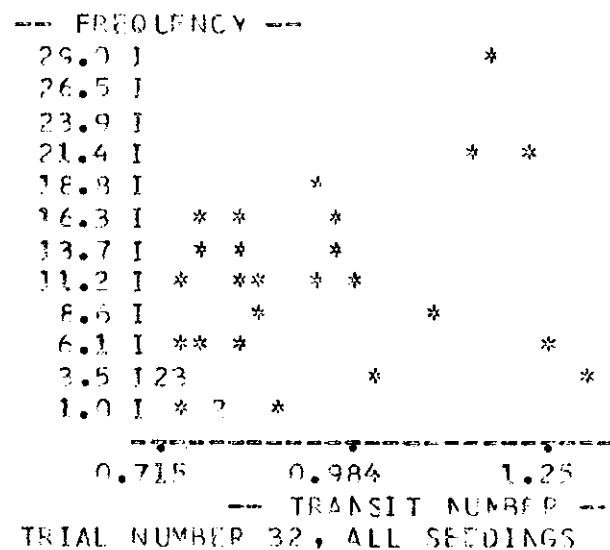
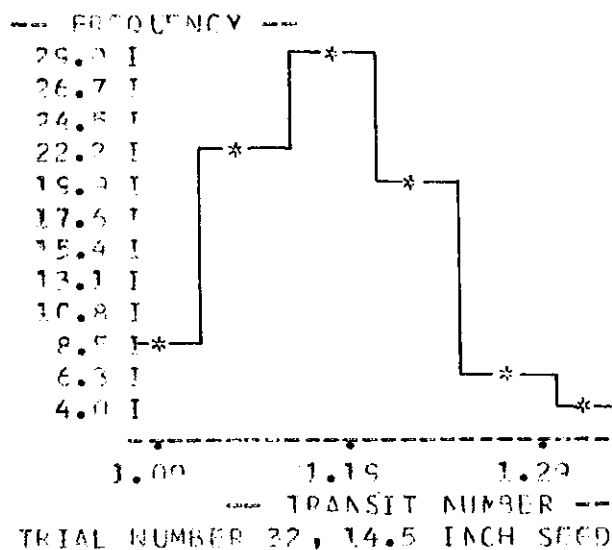
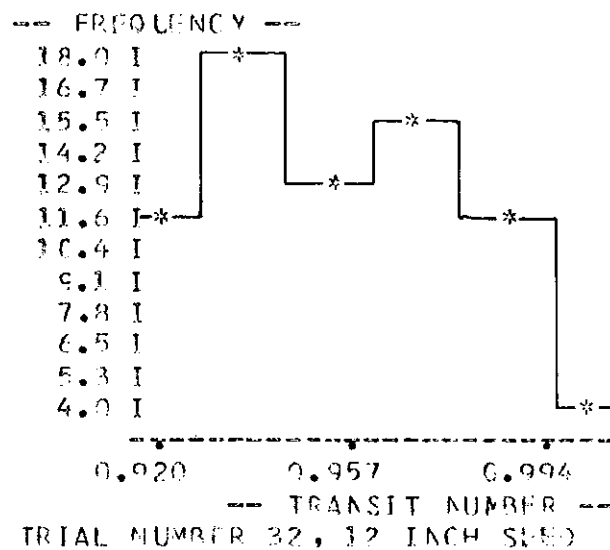
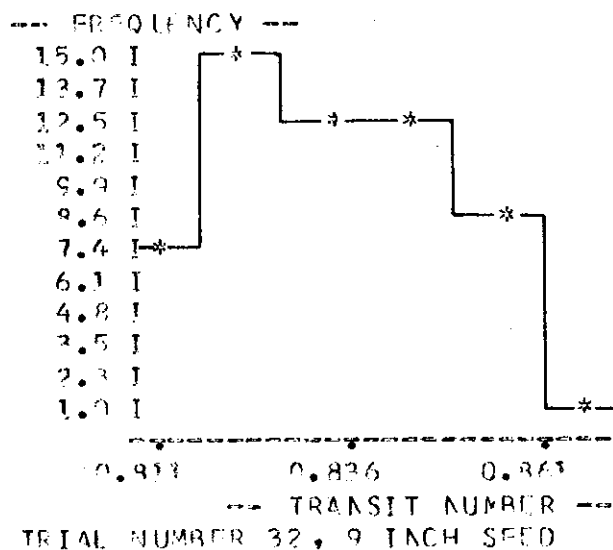
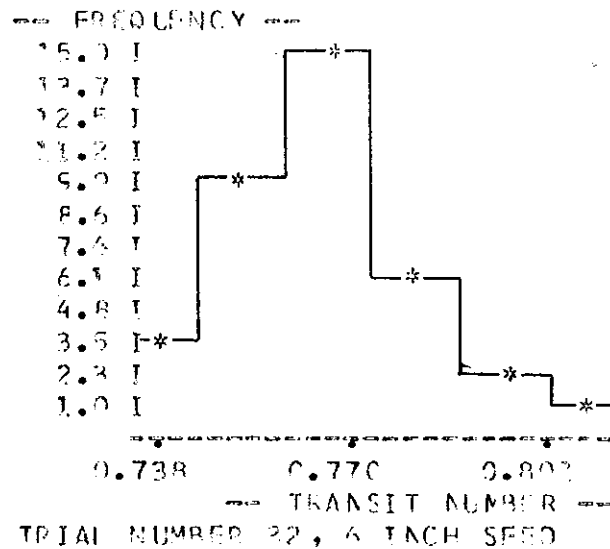
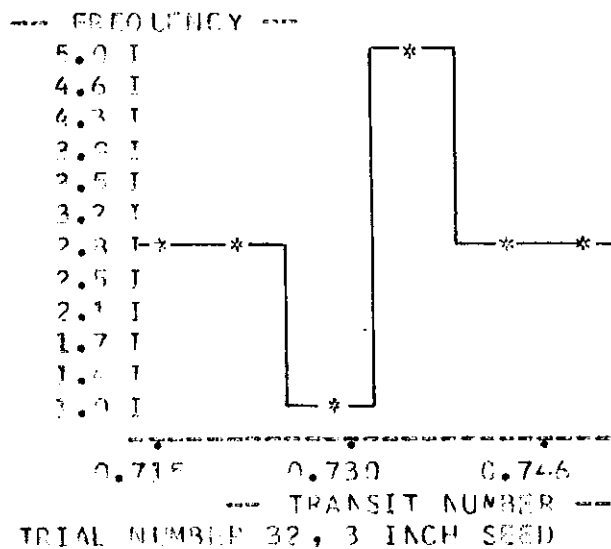

FIGURE 35

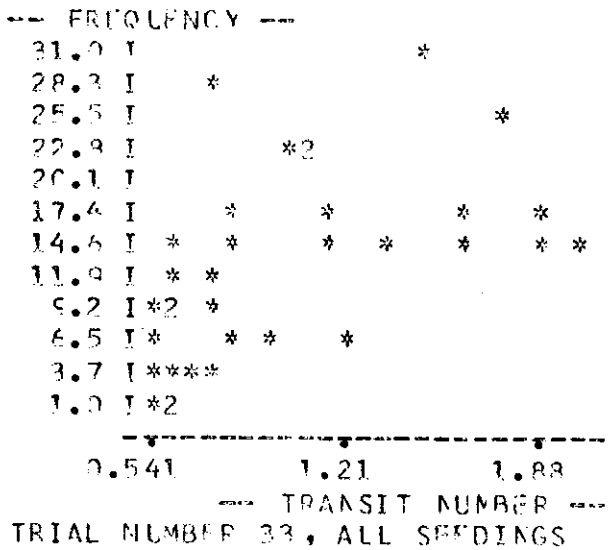
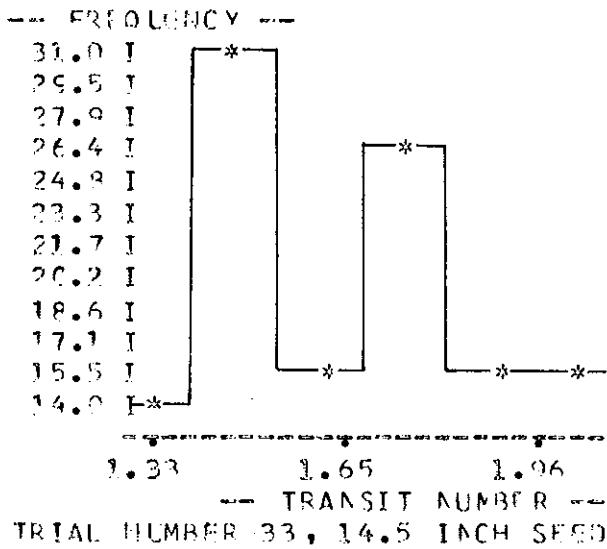
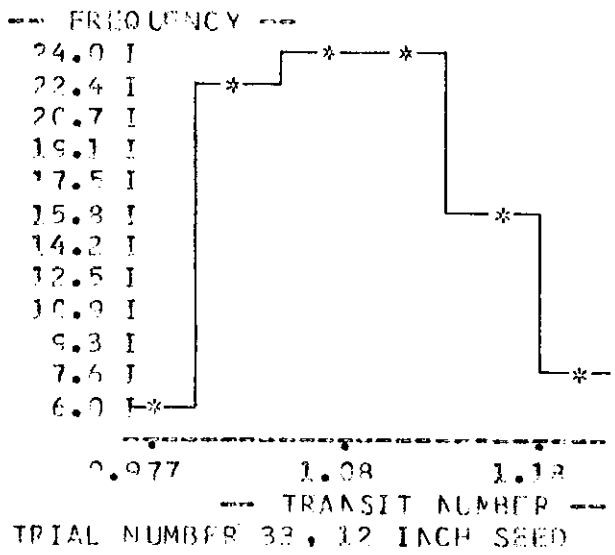
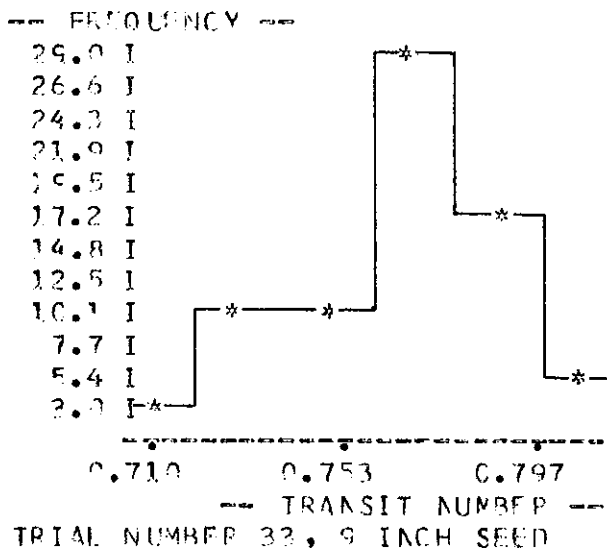
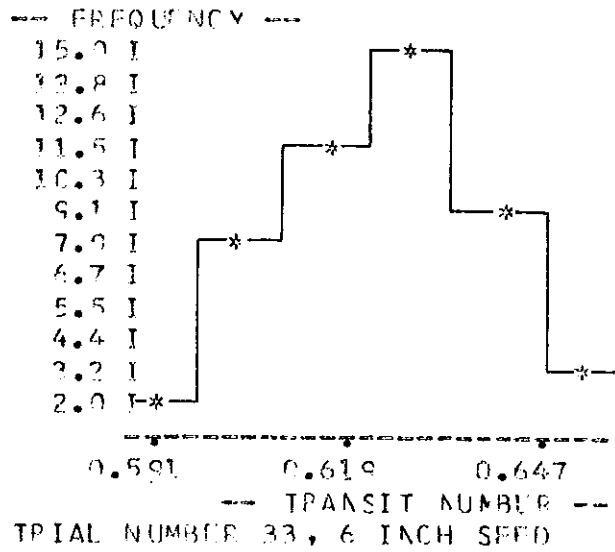
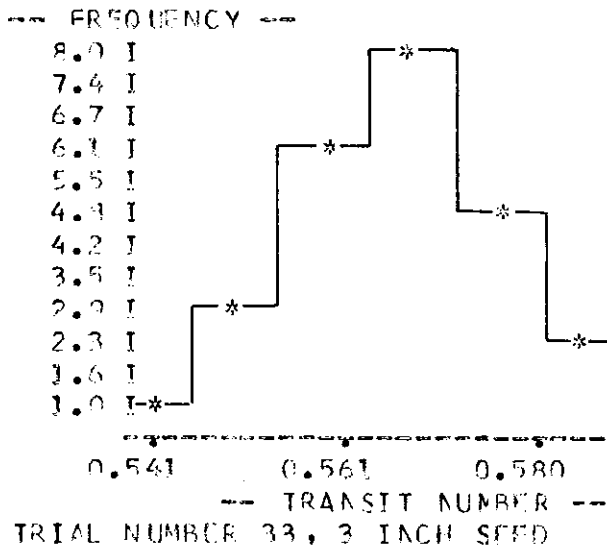

FIGURE 36

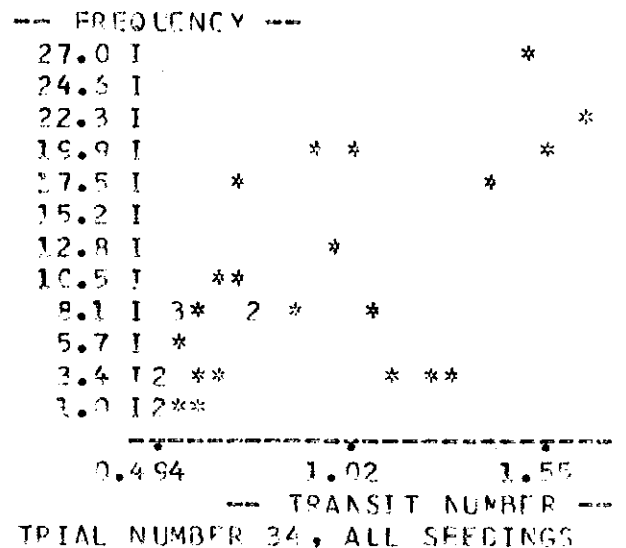
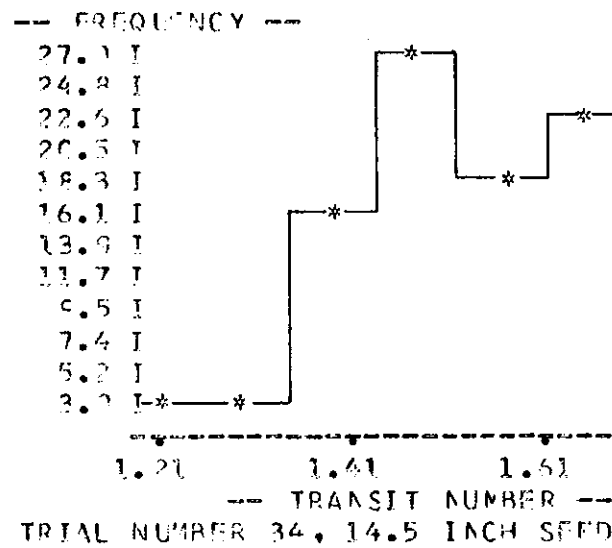
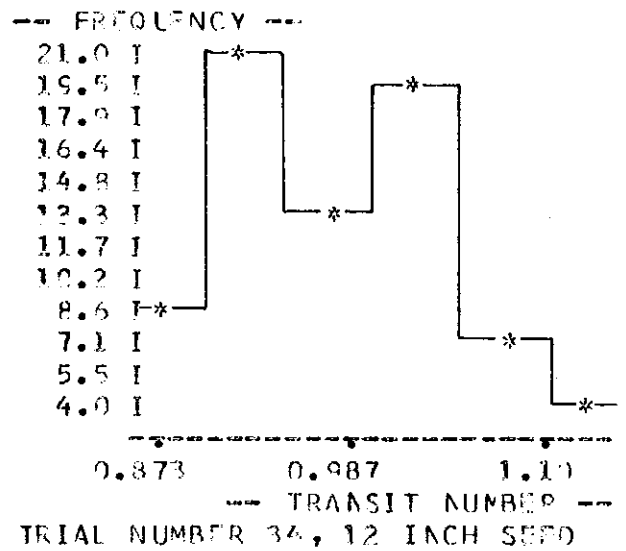
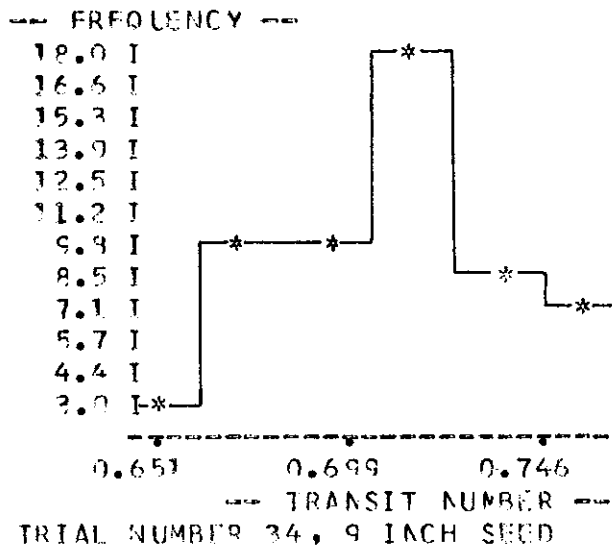
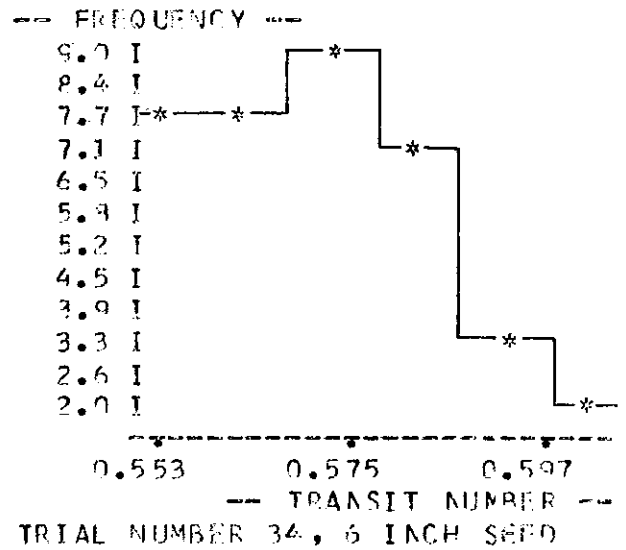
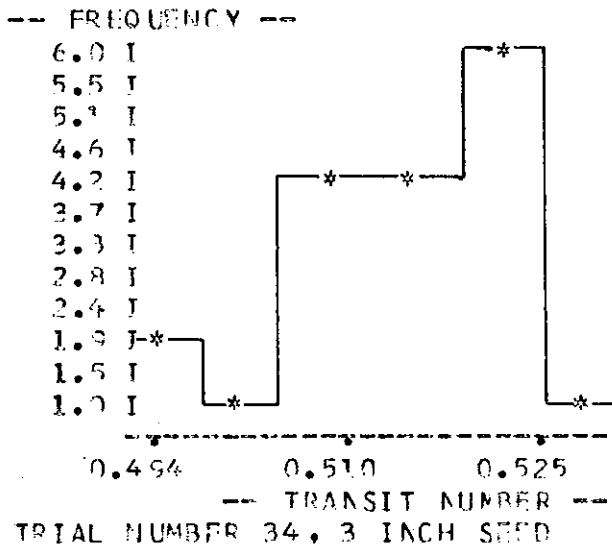

FIGURE 37

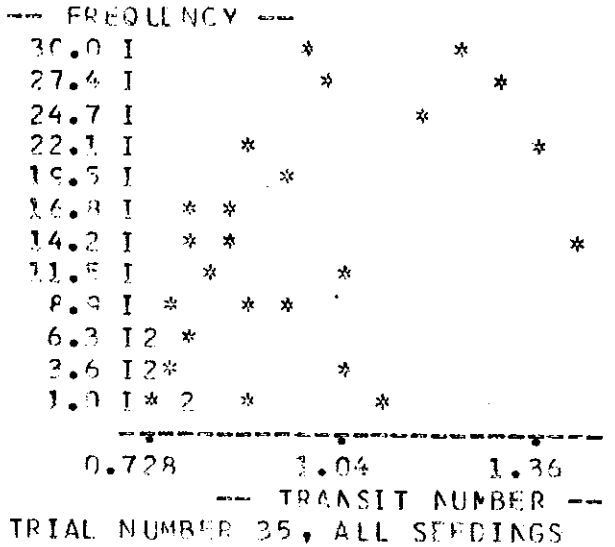
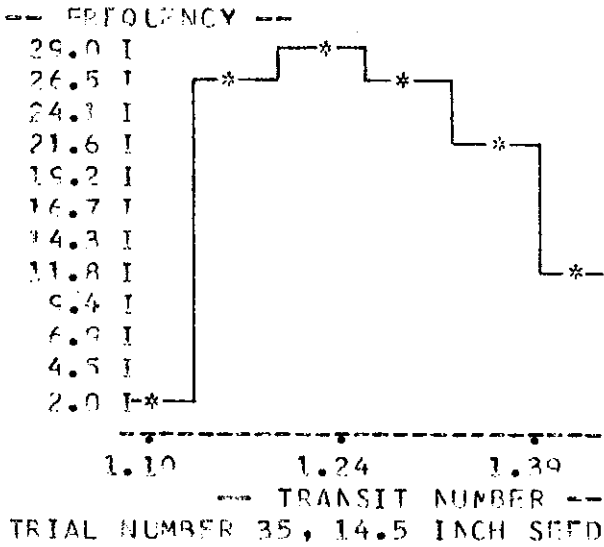
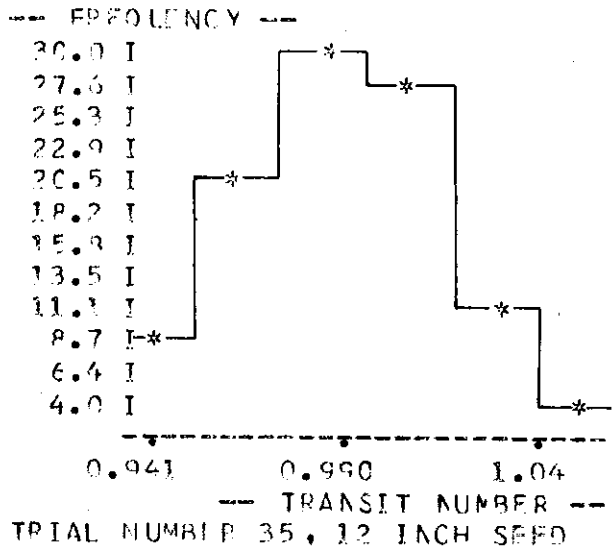
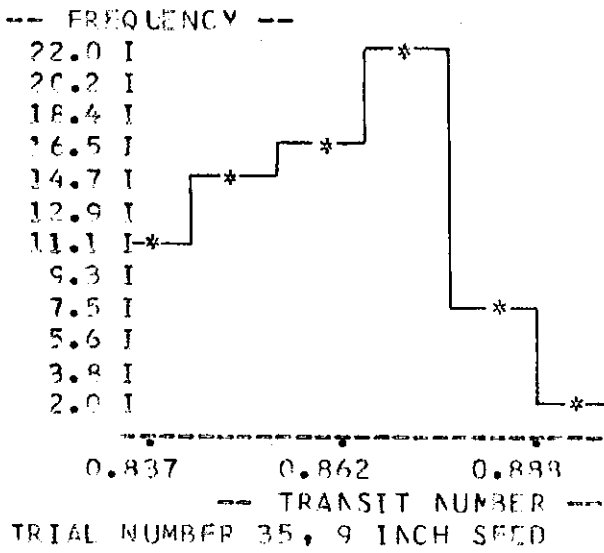
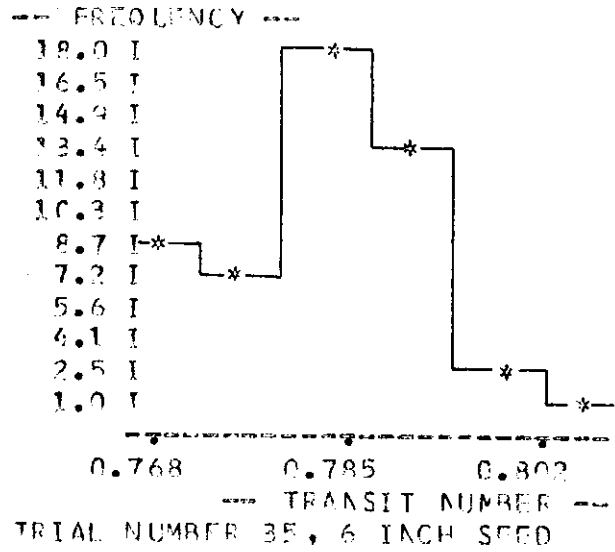
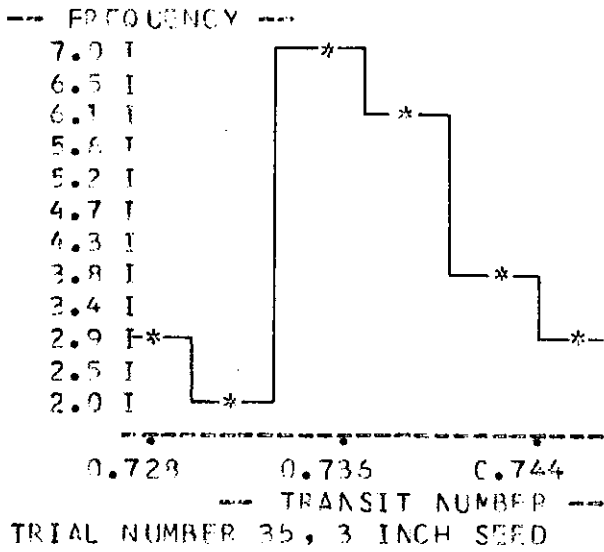

FIGURE 38

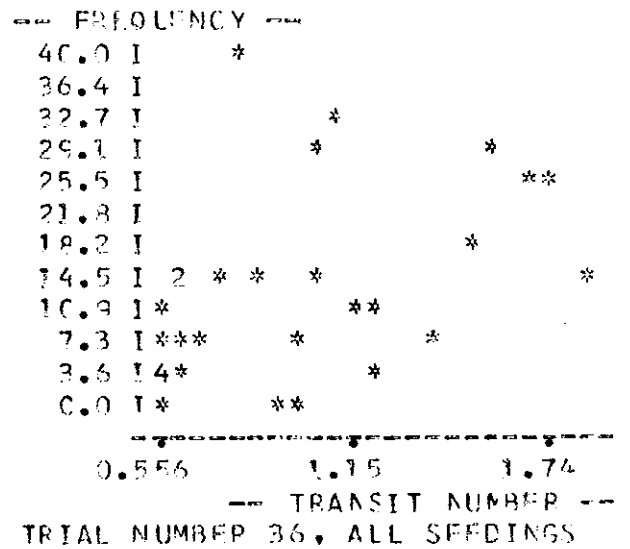
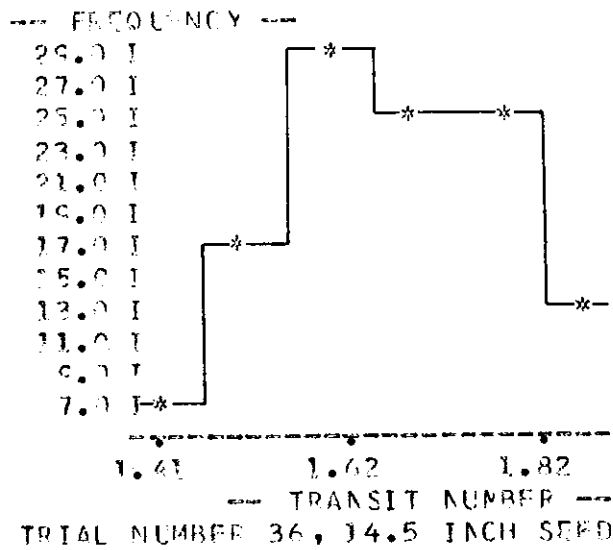
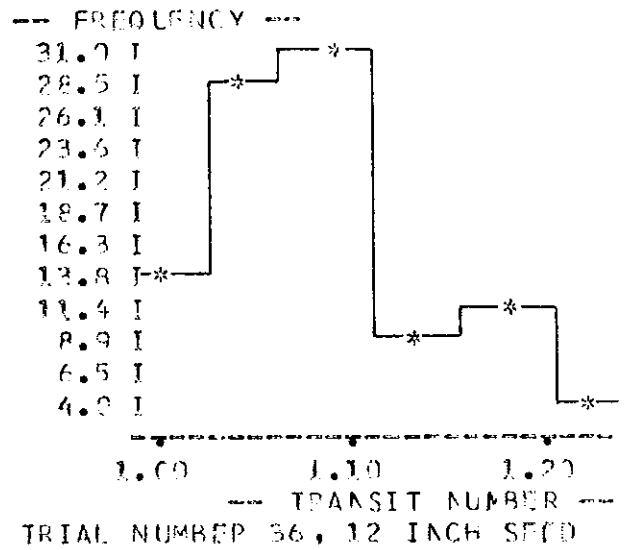
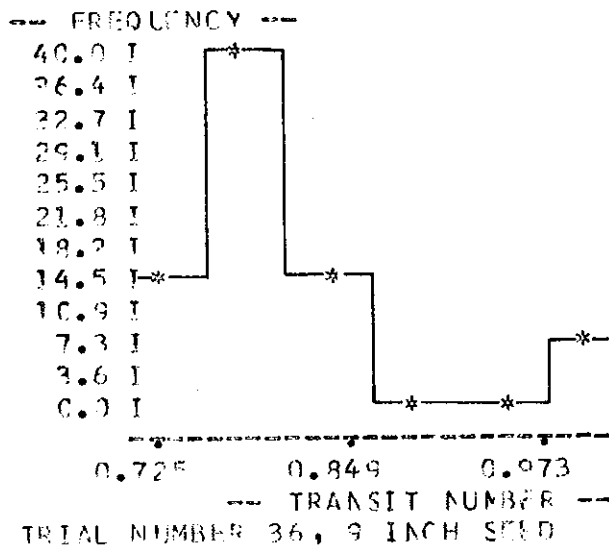
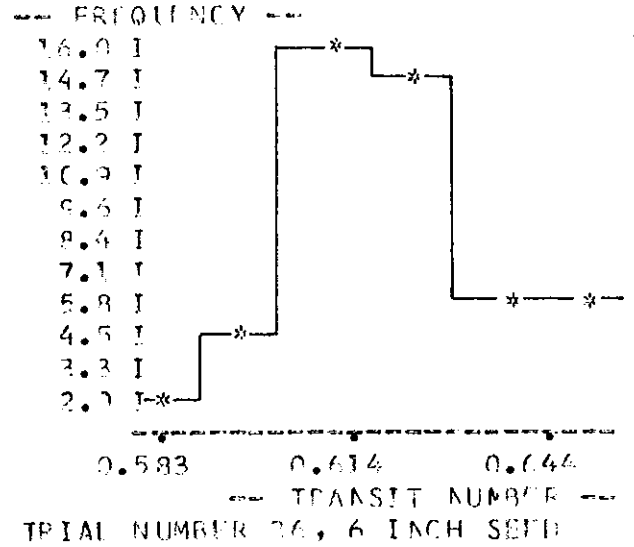
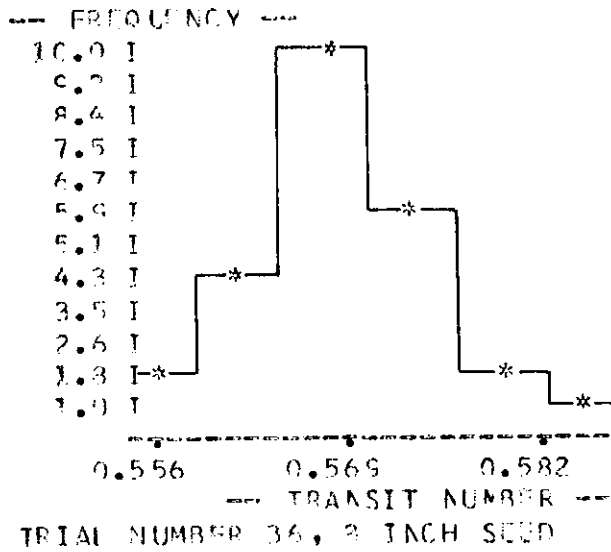

FIGURE 39

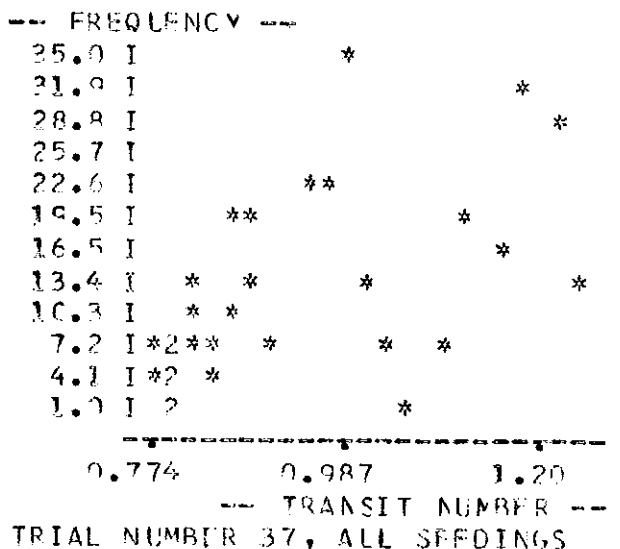
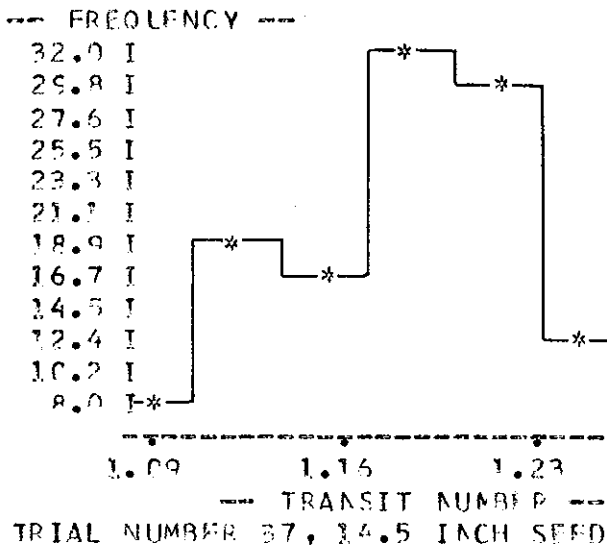
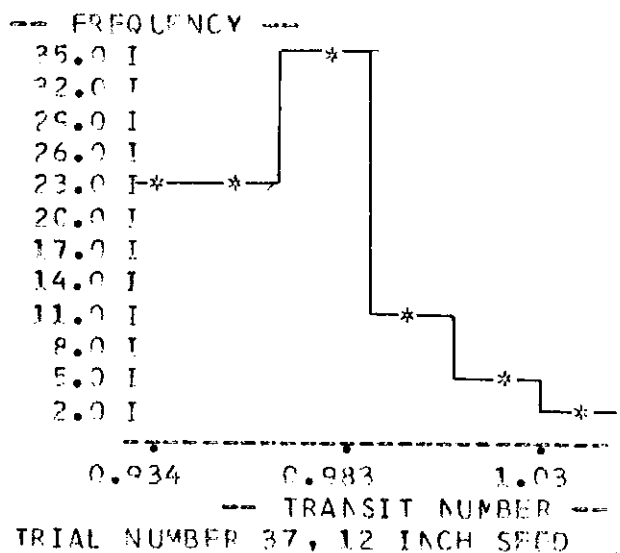
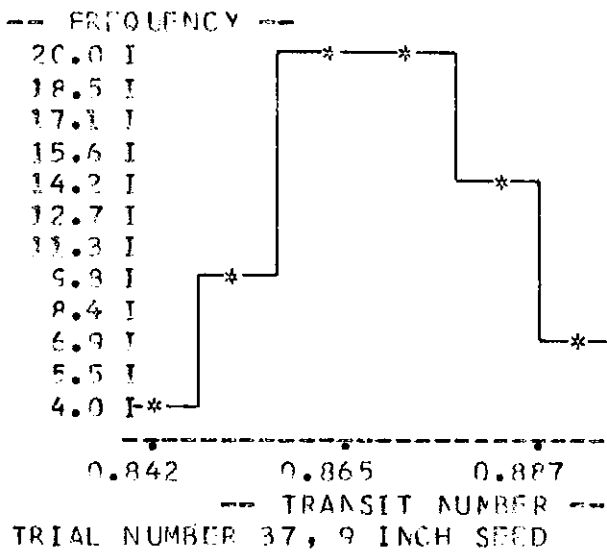
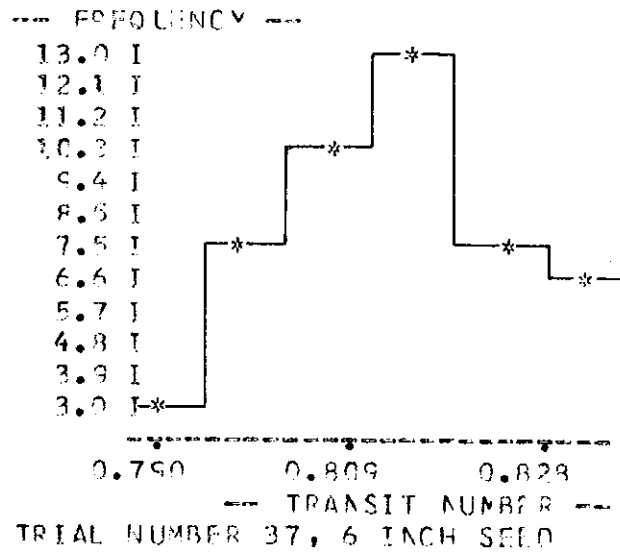
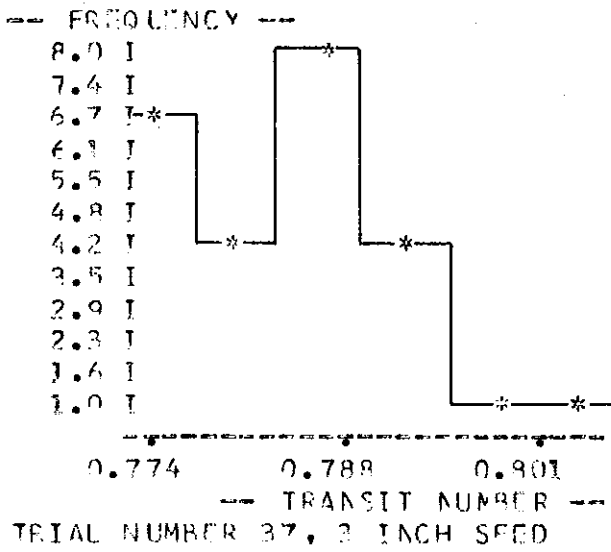

FIGURE 40

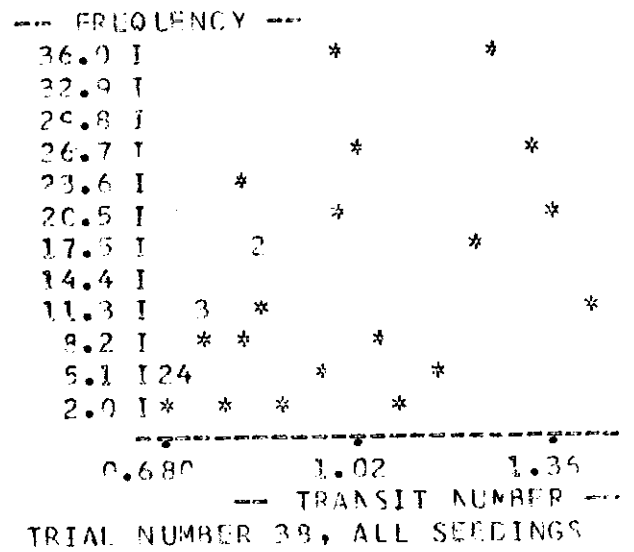
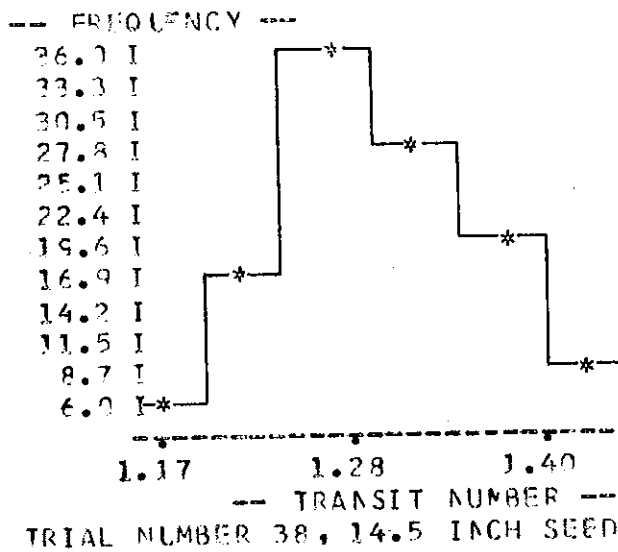
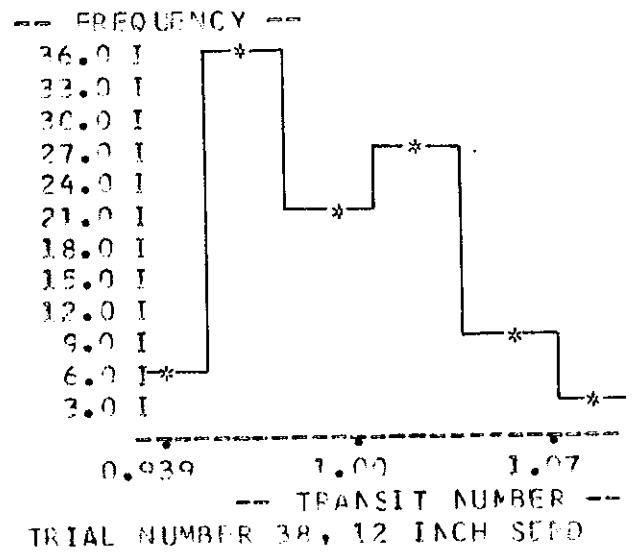
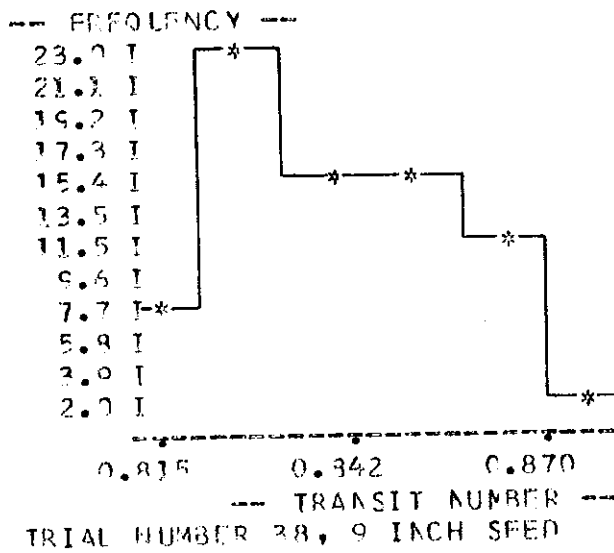
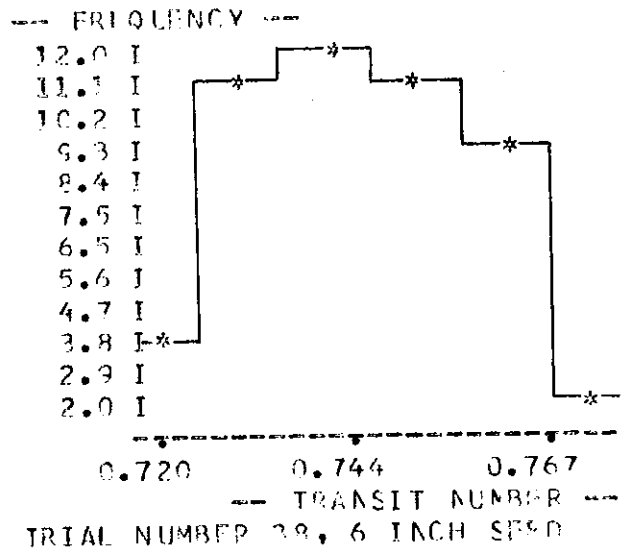
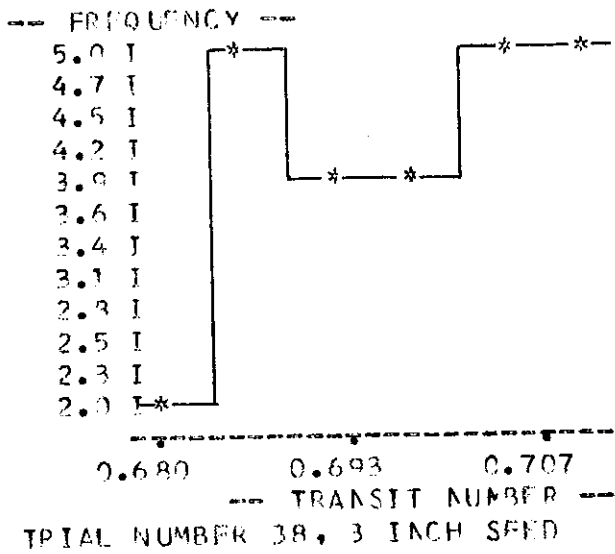
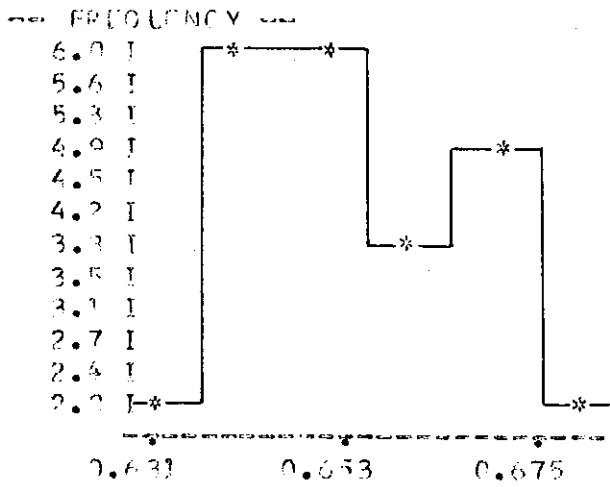
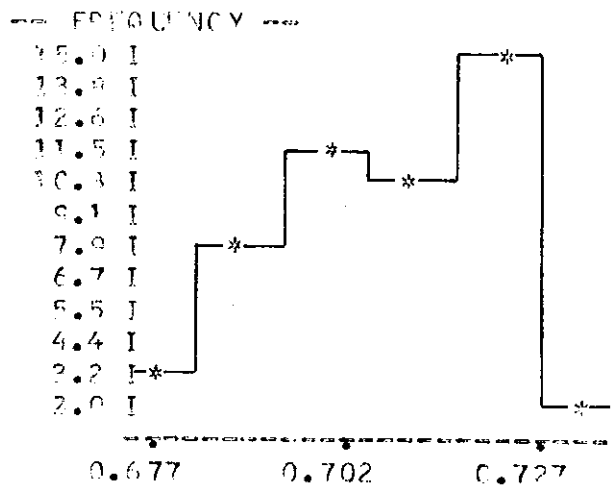

FIGURE 41



TRIAL NUMBER 39, 3 INCH SEED



TRIAL NUMBER 39, 6 INCH SEED

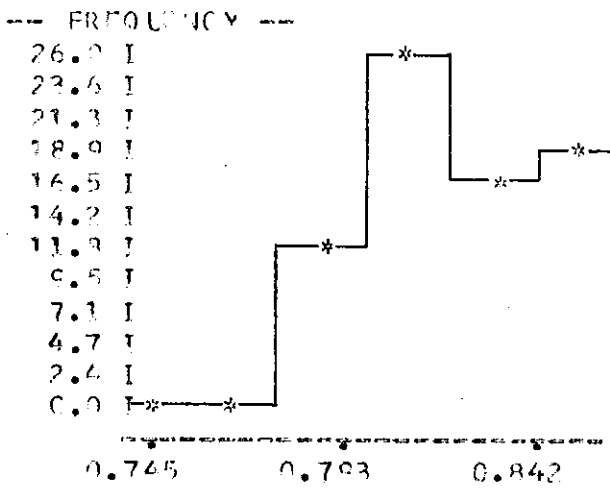

TRIAL NUMBER 39, 9 INCH SEED

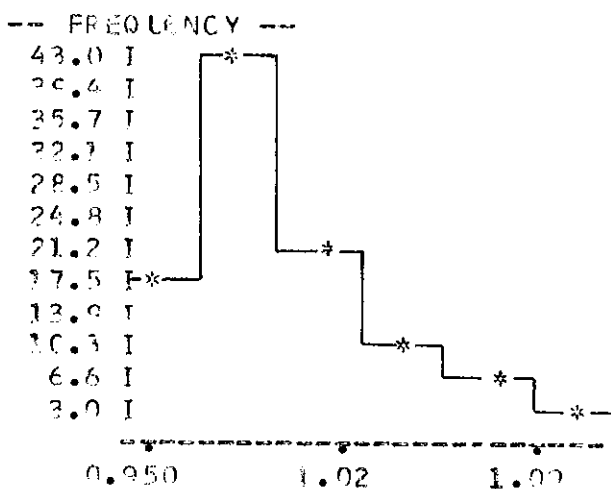

TRIAL NUMBER 39, 12 INCH SEED

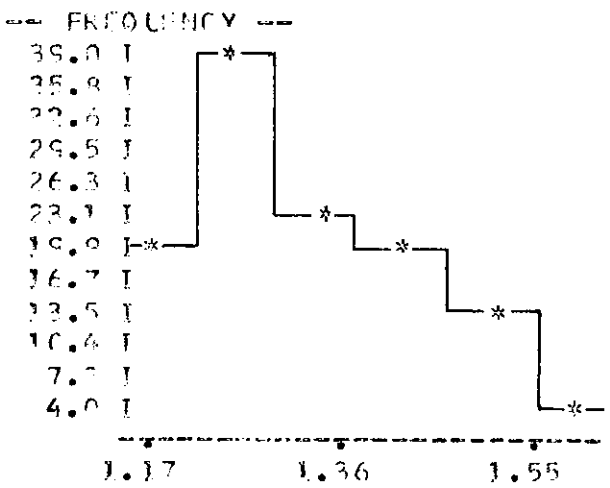

TRIAL NUMBER 39, 14.5 INCH SEED

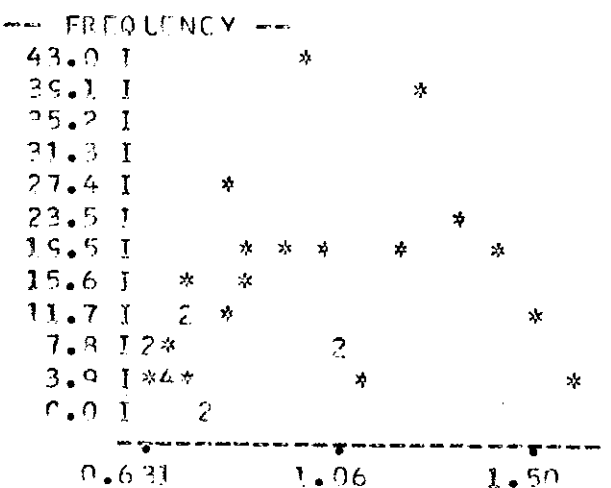

TRIAL NUMBER 39, ALL SEEDINGS

FIGURE 42

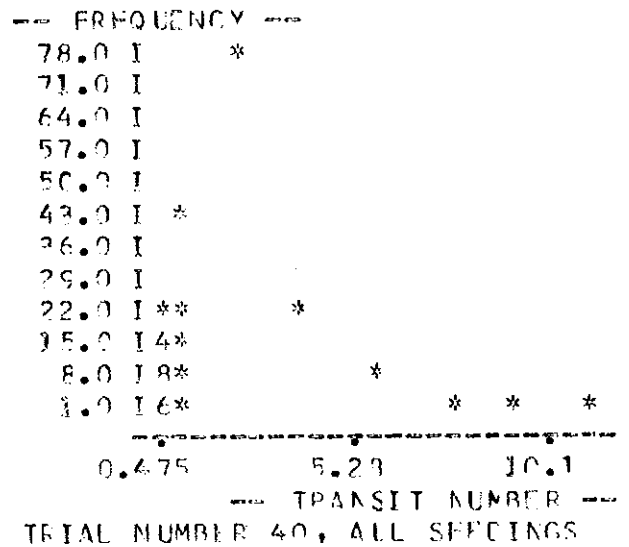
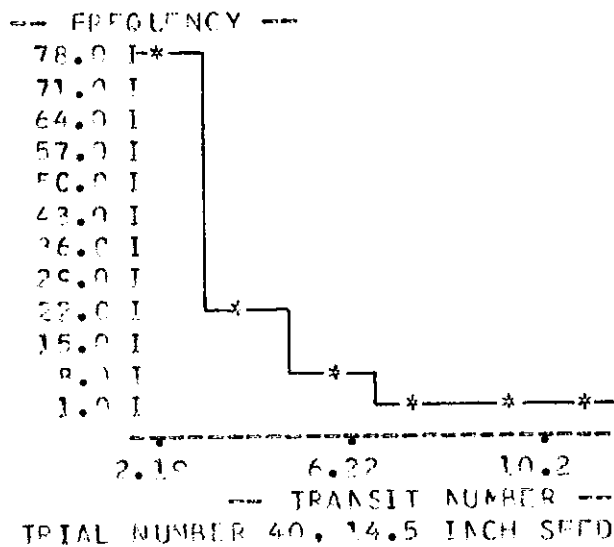
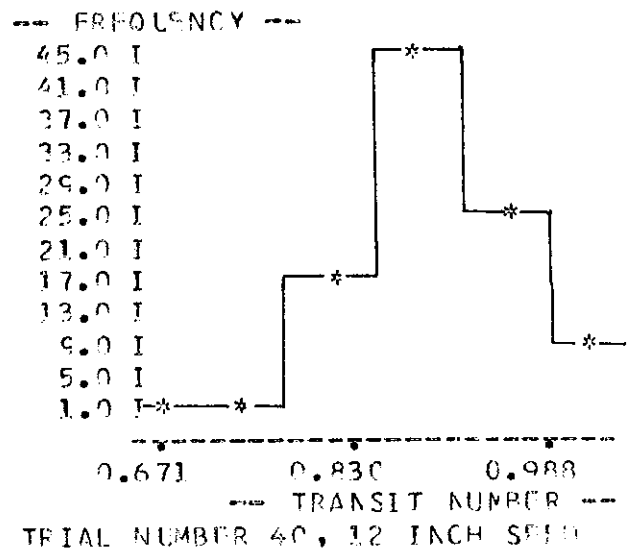
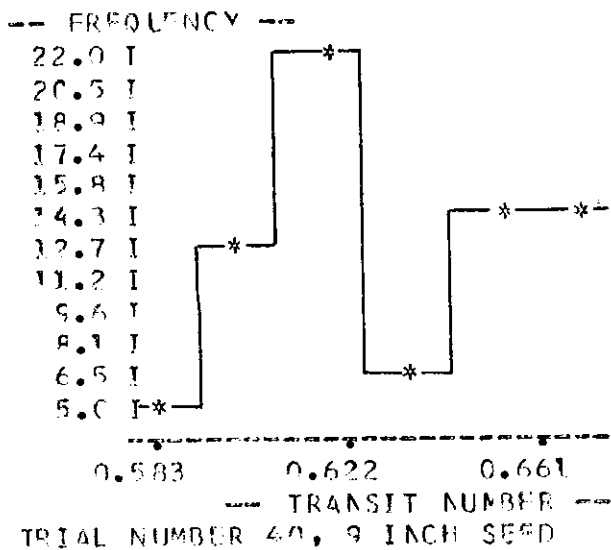
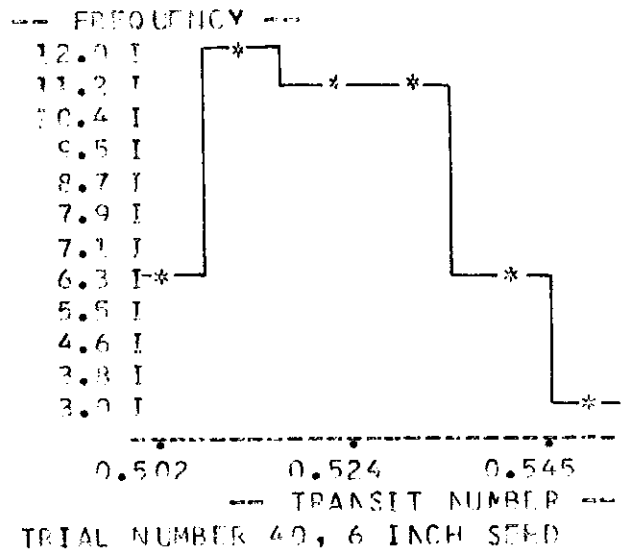
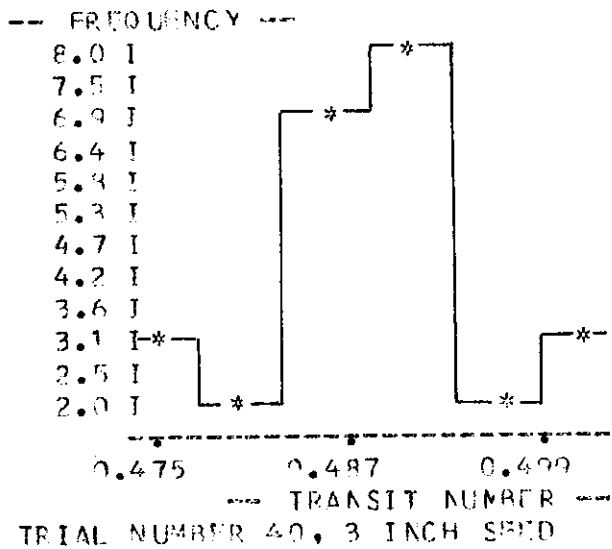

FIGURE 43

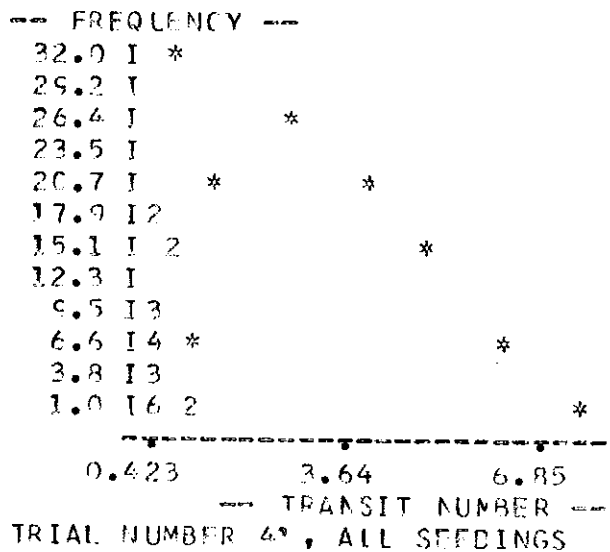
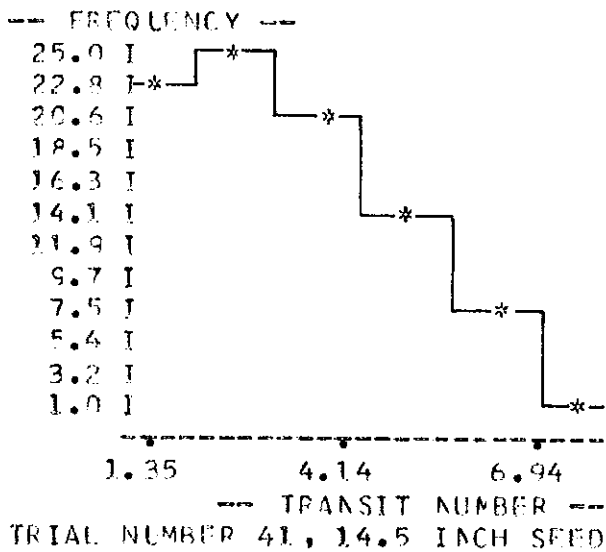
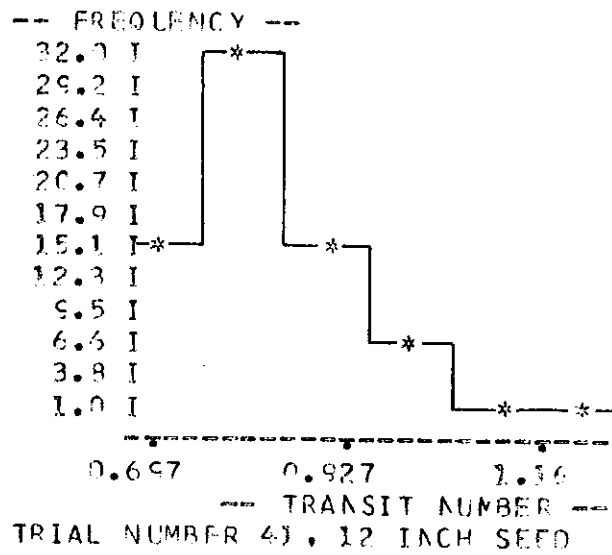
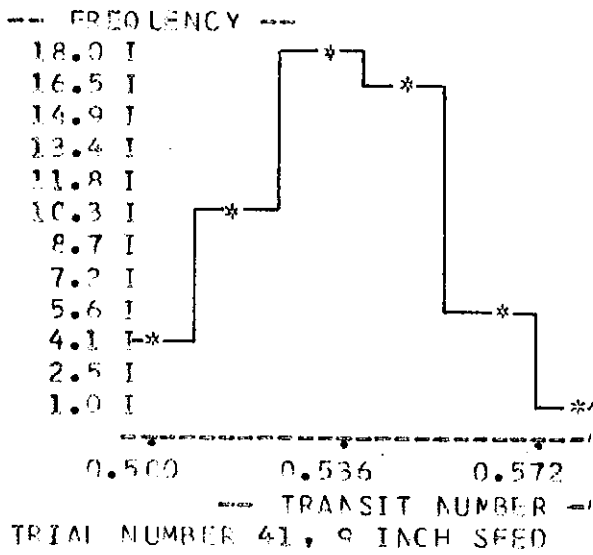
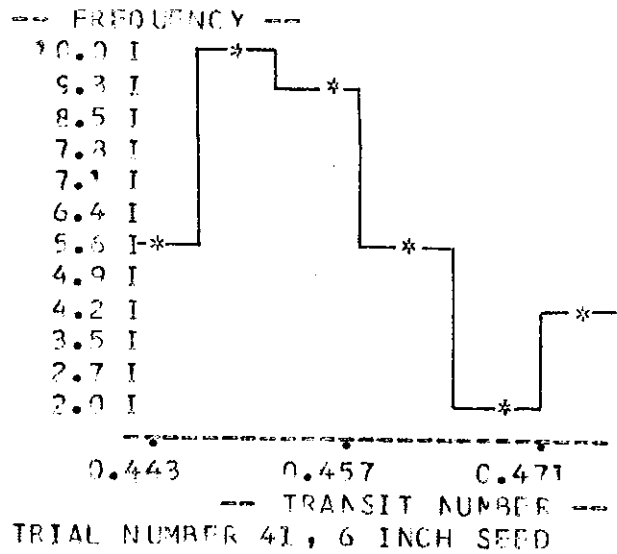
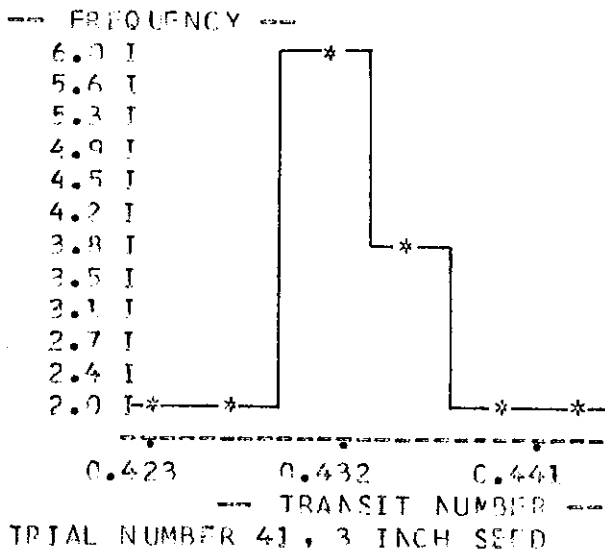

FIGURE 44

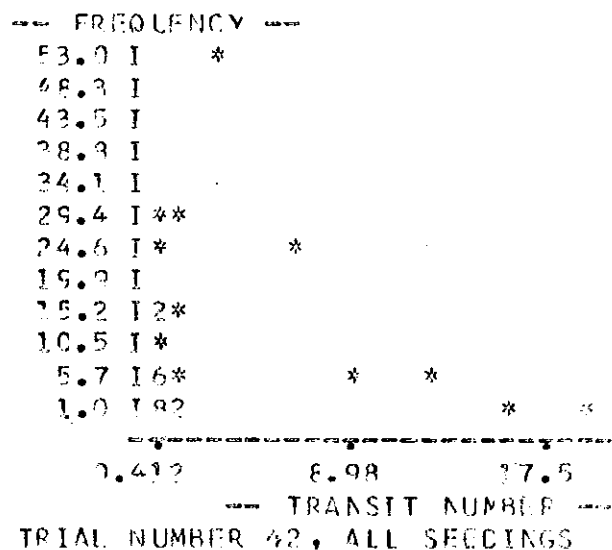
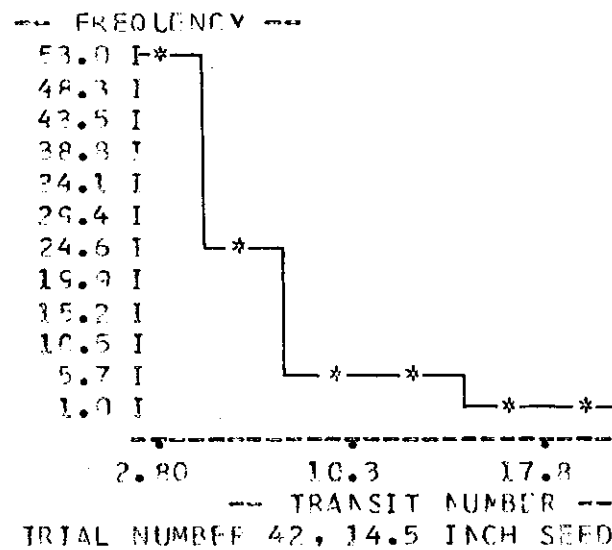
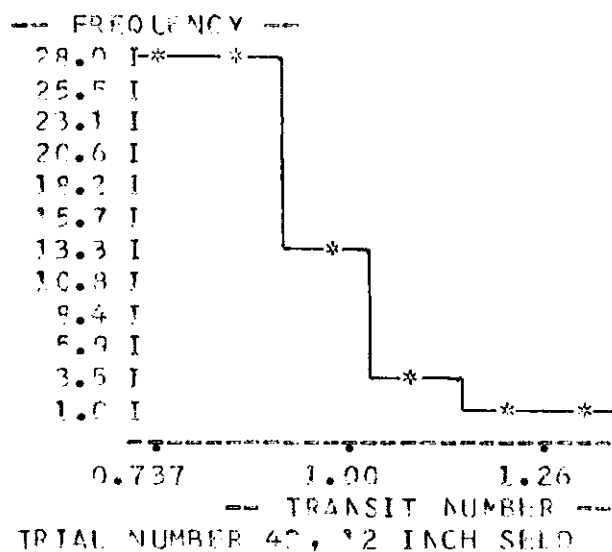
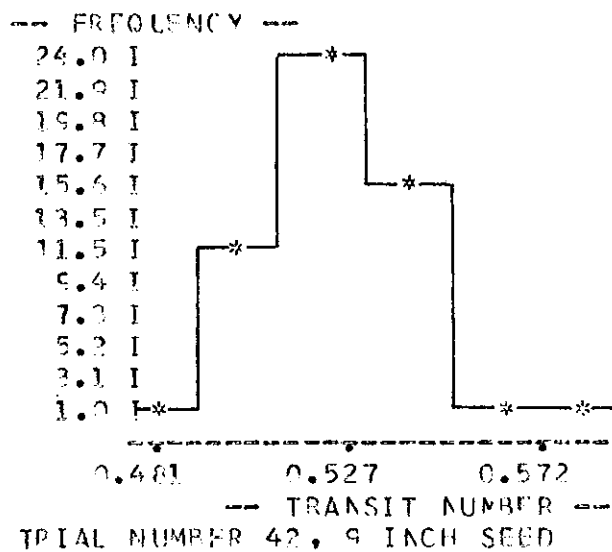
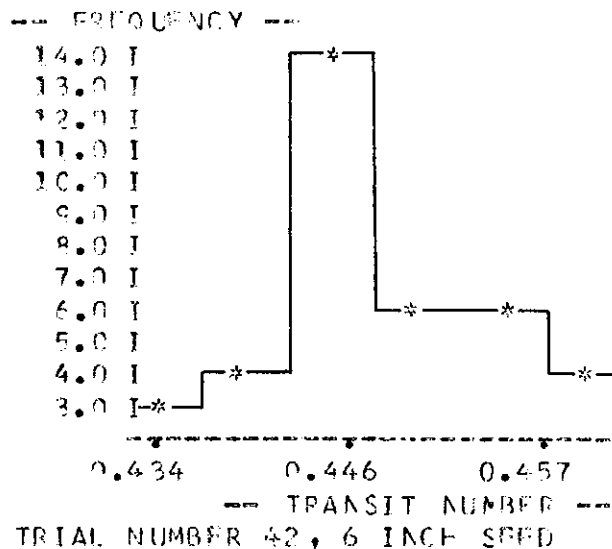
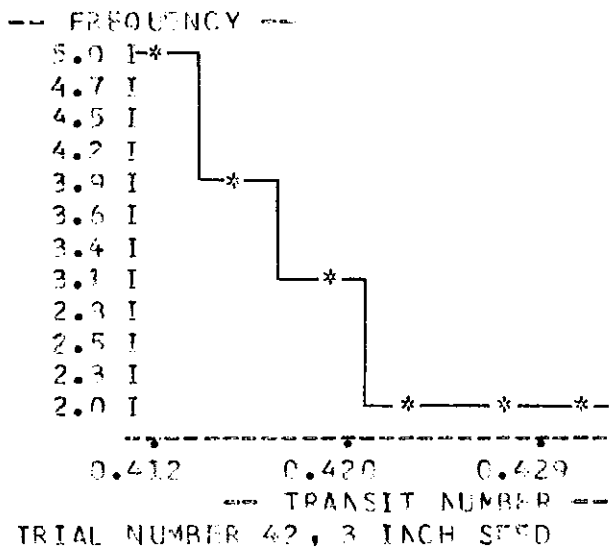

FIGURE 45

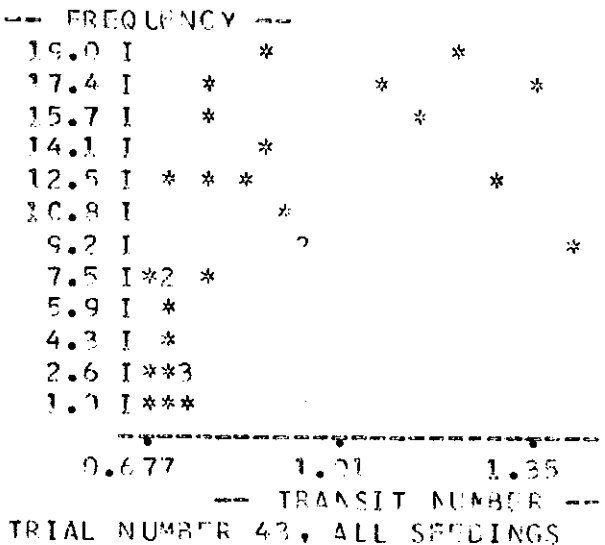
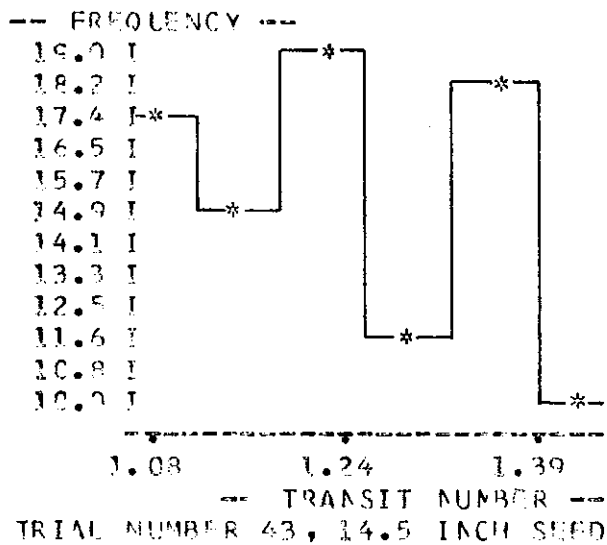
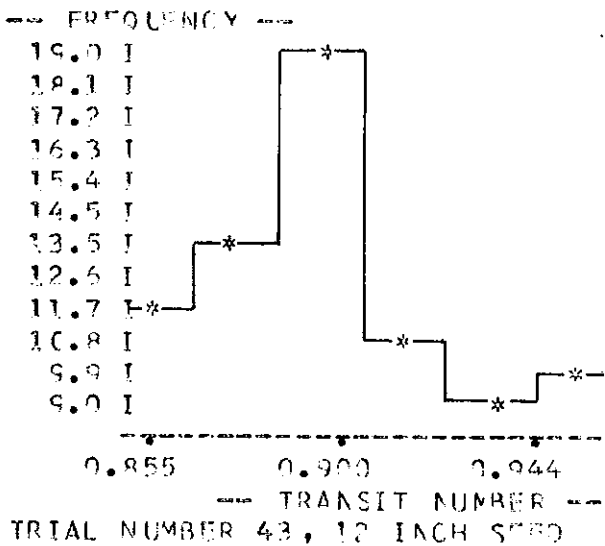
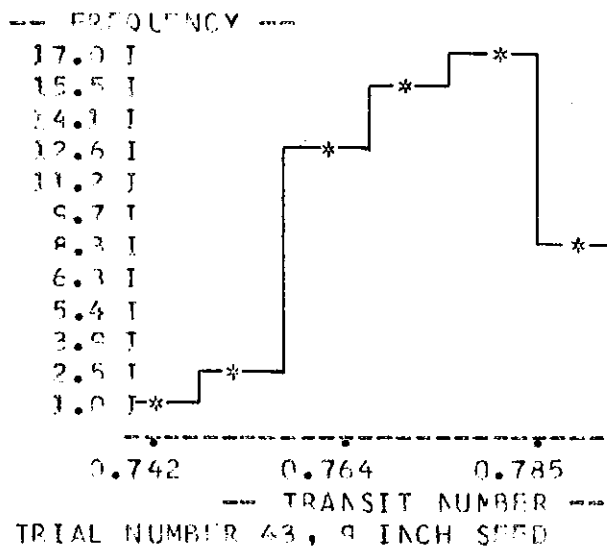
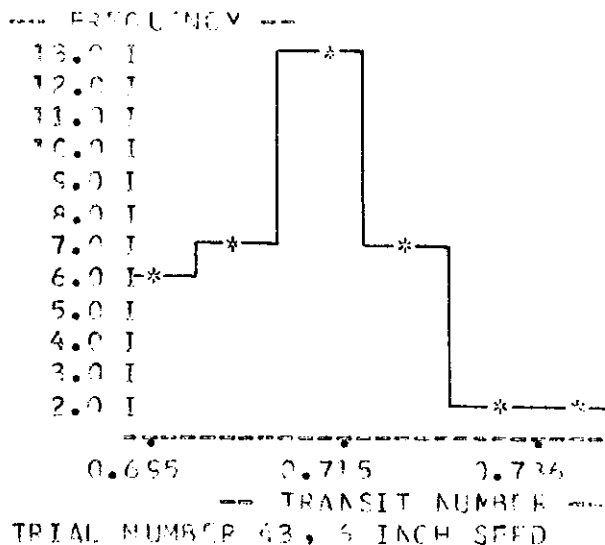
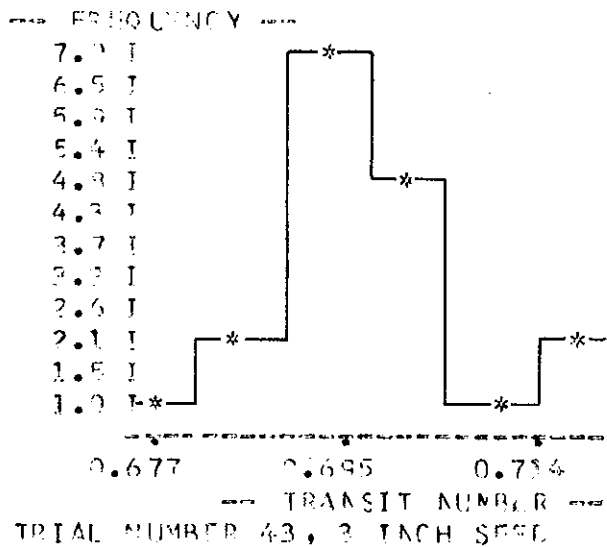

FIGURE 46

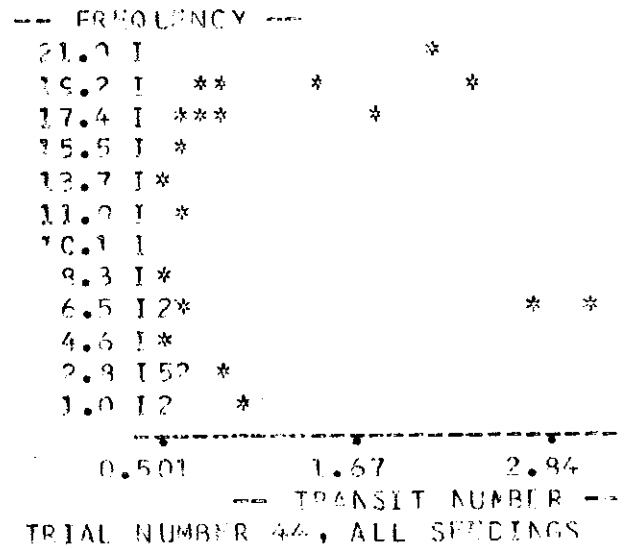
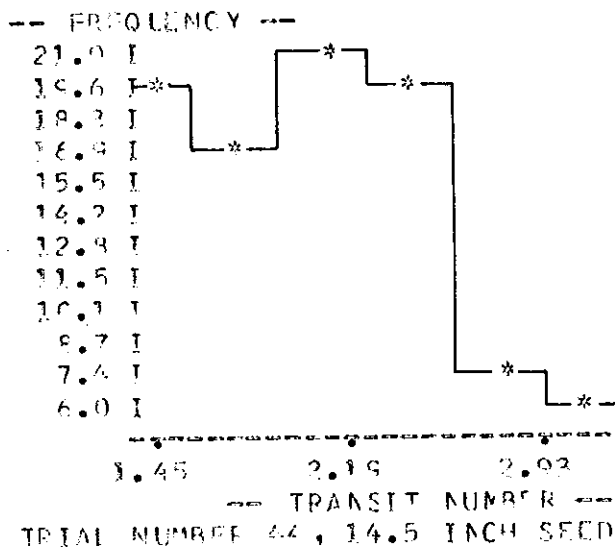
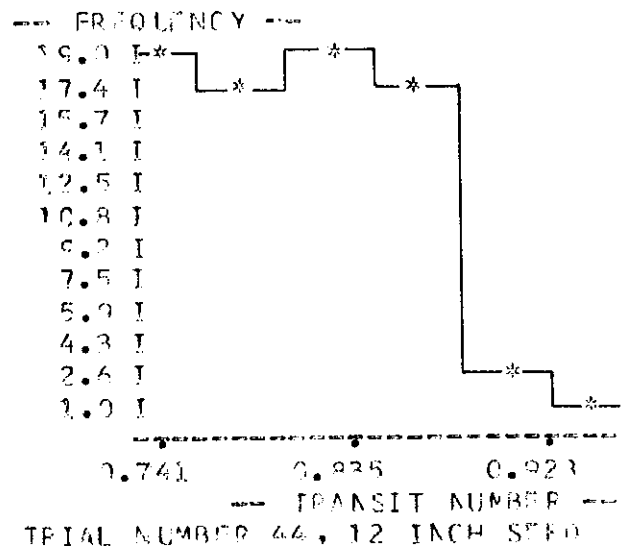
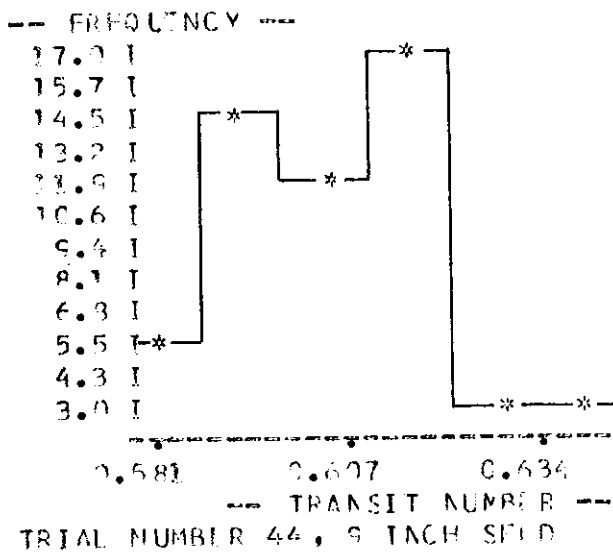
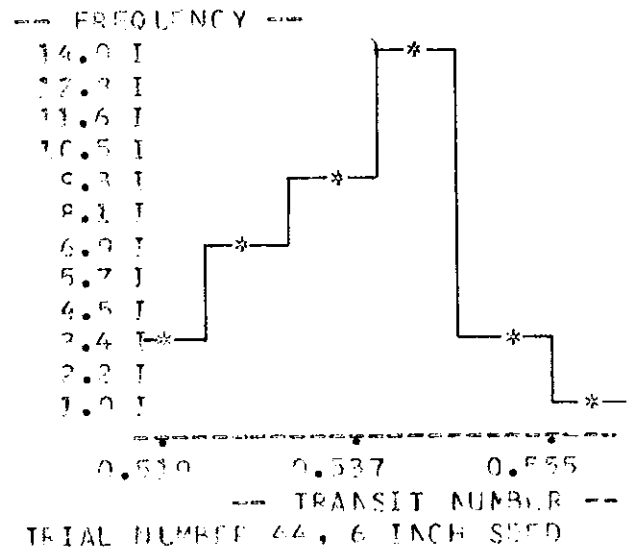
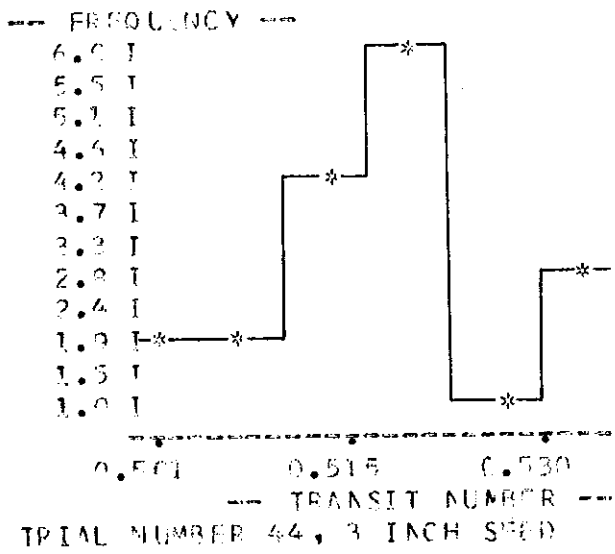
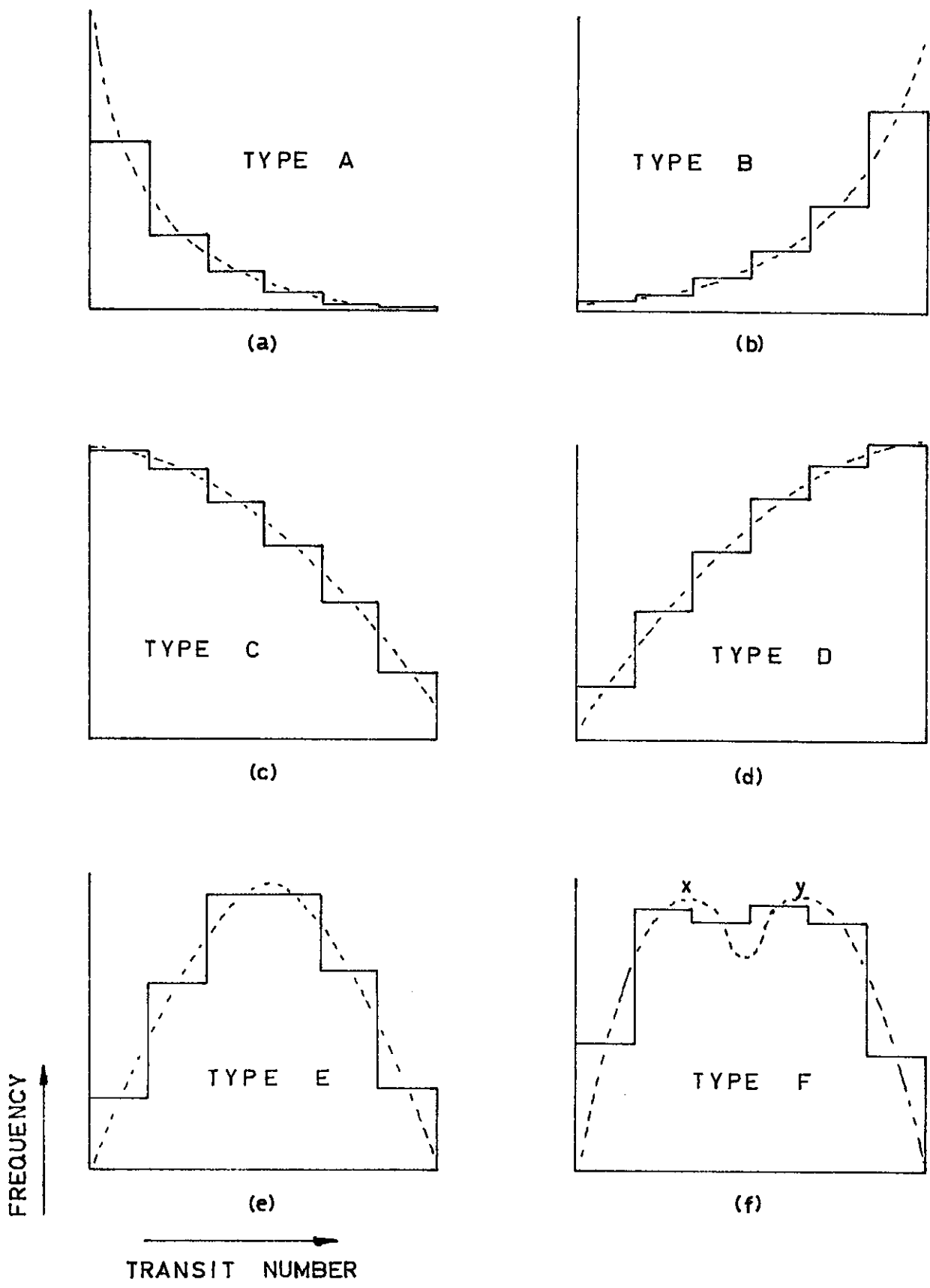

FIGURE 47



**FIGURE 48. TRANSIT NUMBER SPECTRAL TYPES**

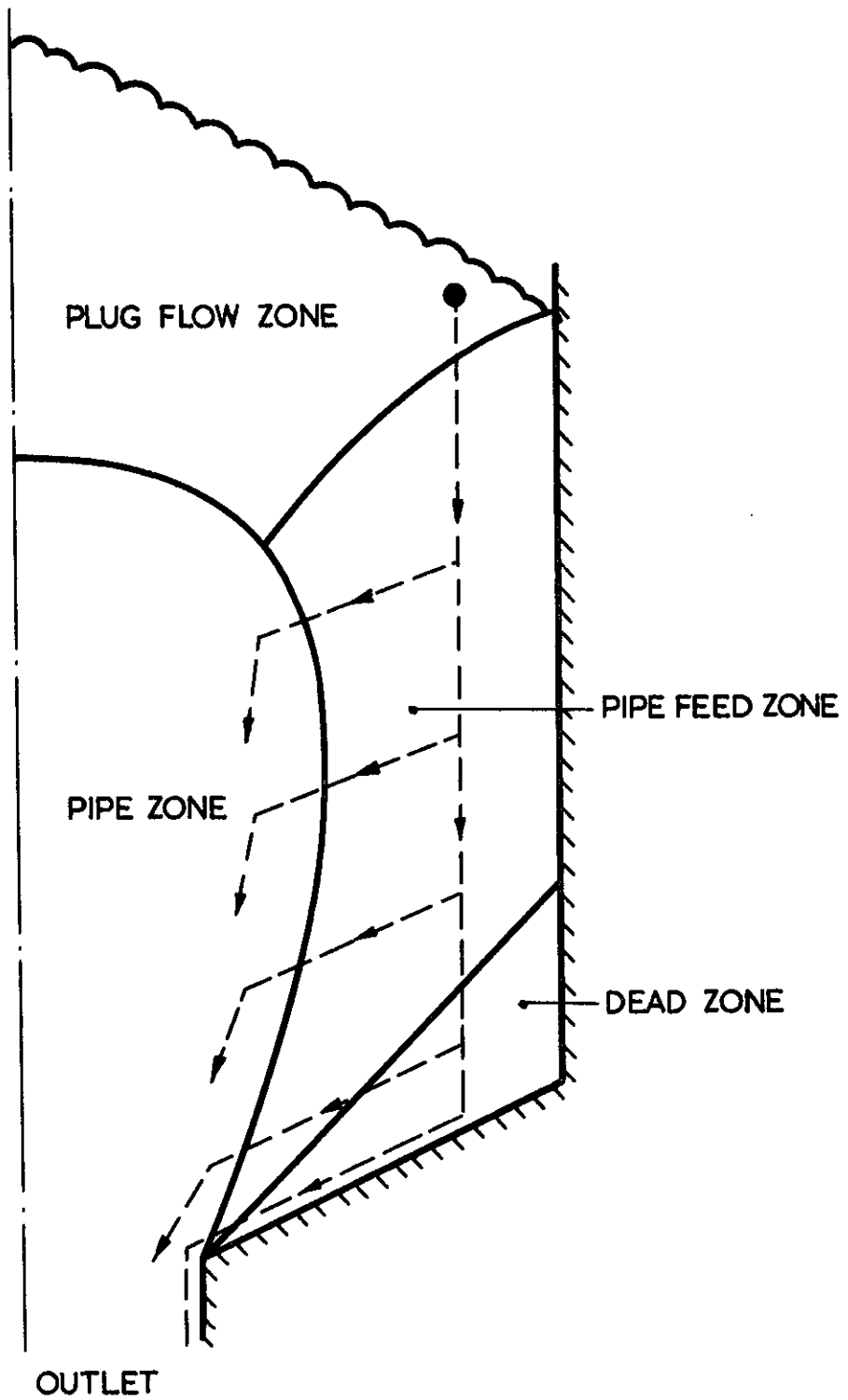

FIGURE 49. ASSUMED PEBBLE PATHS IN WALL REGION AND FLOW ZONES

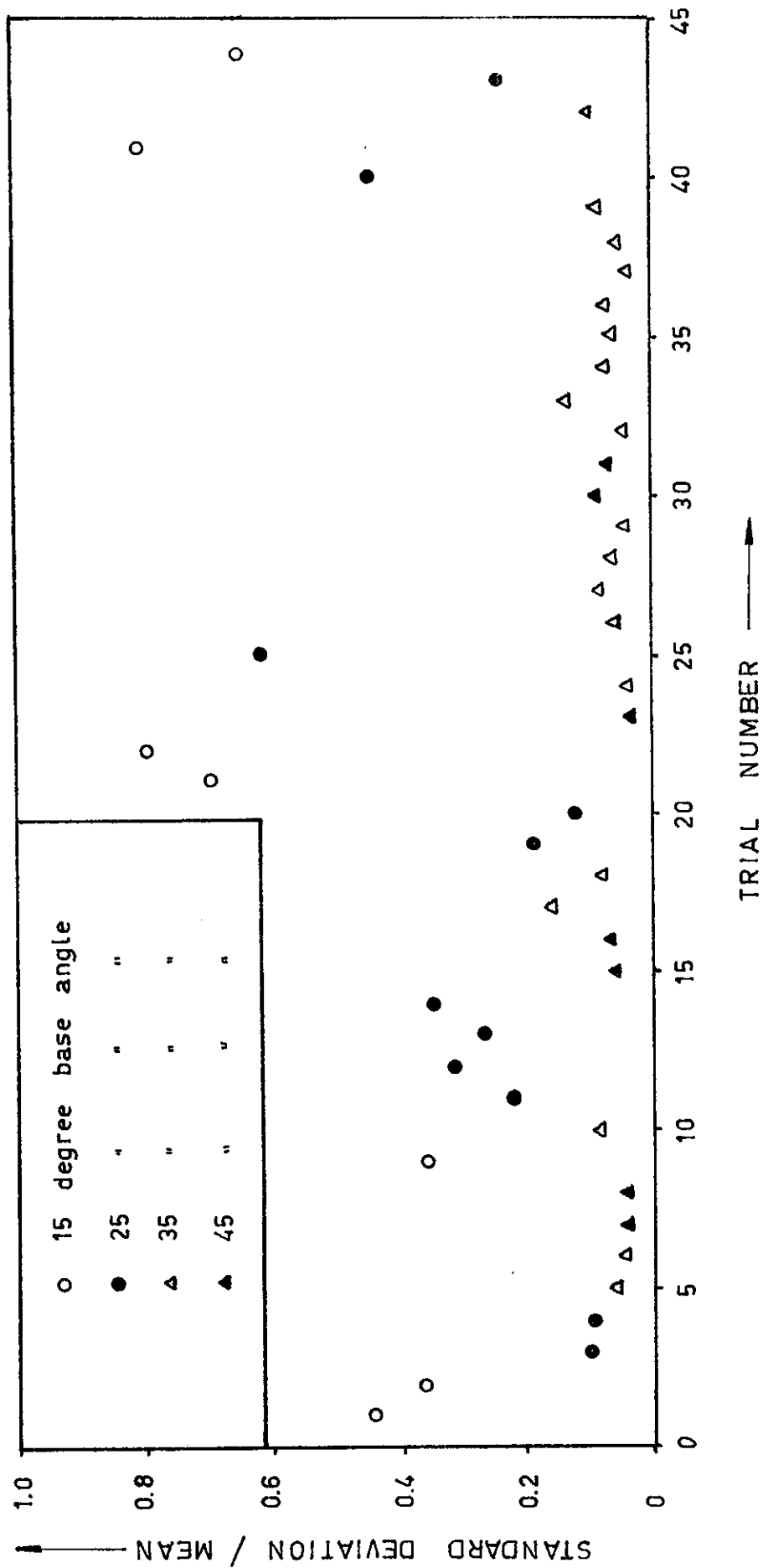
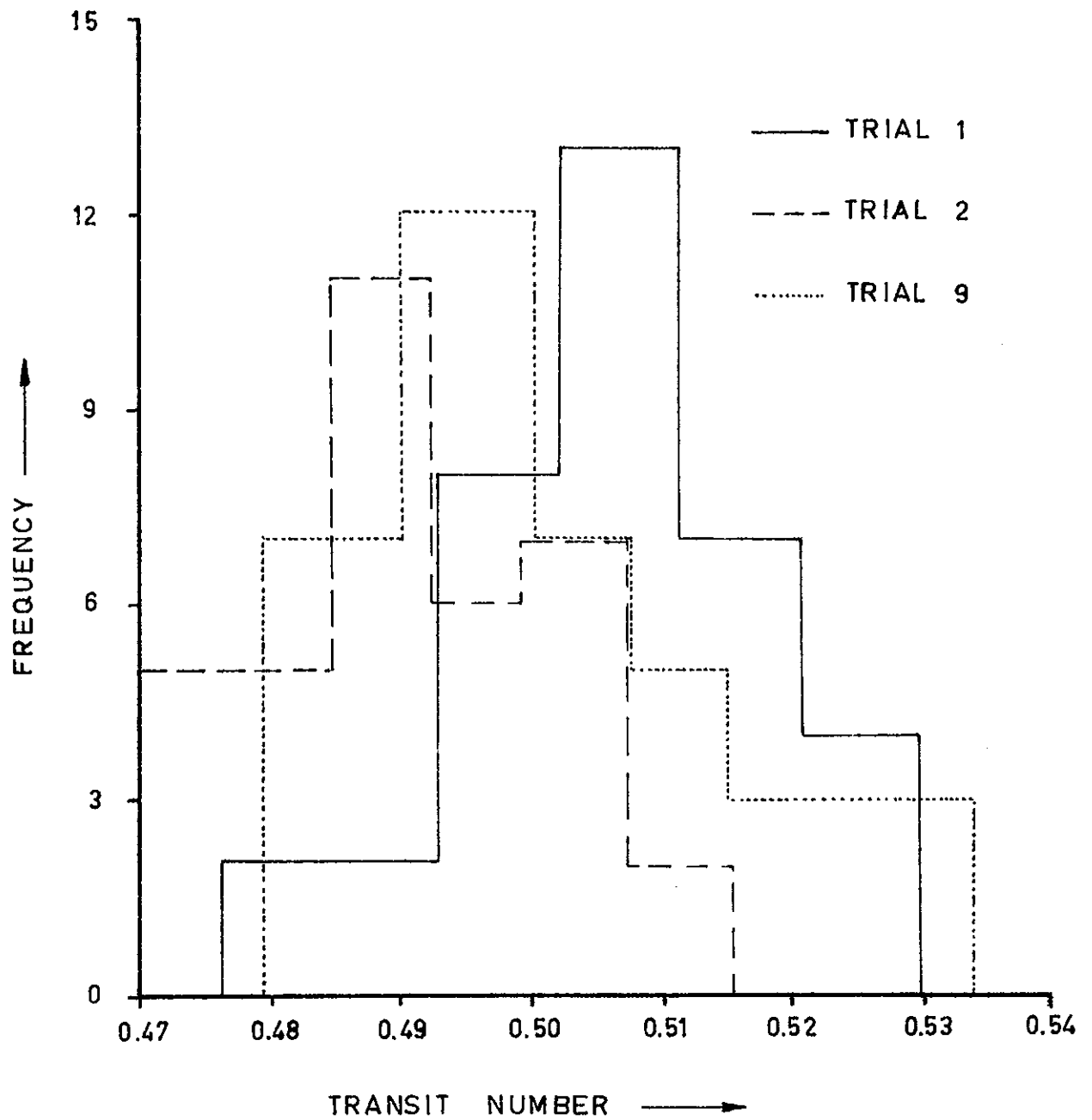
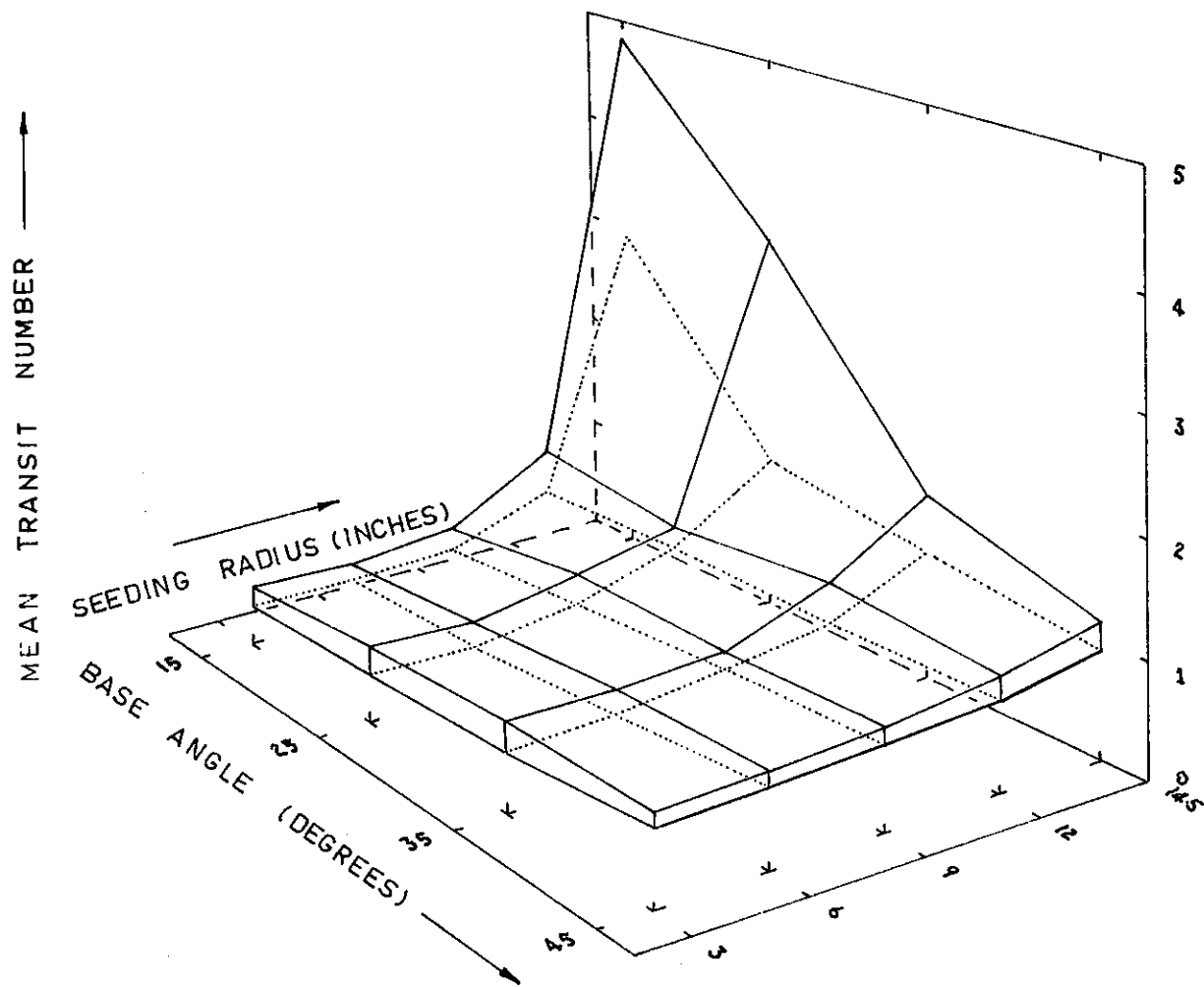

FIGURE 50. STANDARD DEVIATION VERSUS MEAN RATIO FOR ALL TRIALS AT 14.5 INCH SEEDING RADIUS



**FIGURE 51. TRANSIT NUMBER SPECTRA FOR TRIALS 1, 2 AND 9 AT 6 INCH SEEDING RADIUS**



**FIGURE 52. RANGE OF TRANSIT NUMBER SPECTRAL MEANS FOR VARYING BASE ANGLE AND SEEDING RADIUS**

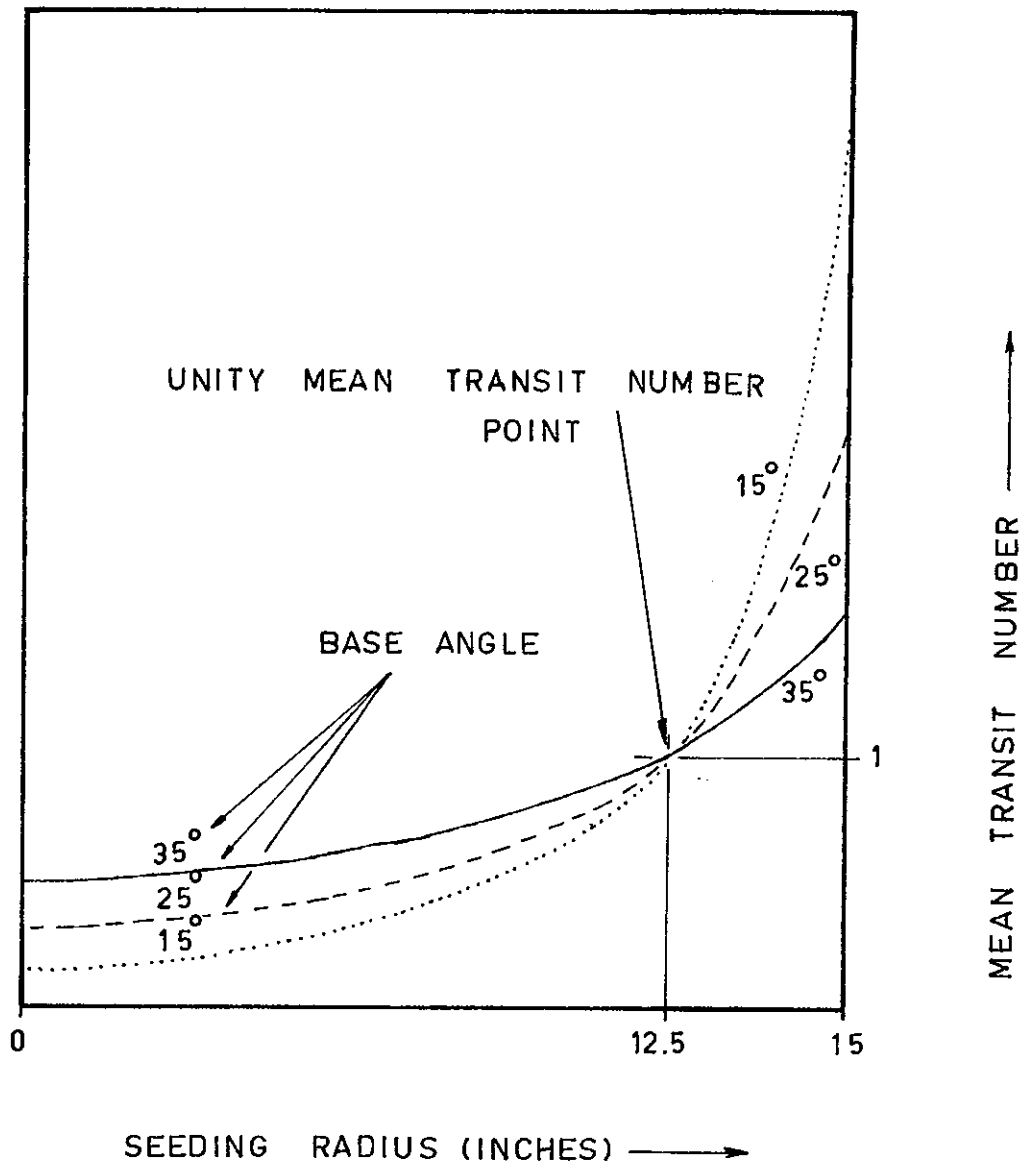

**FIGURE 53. DIAGRAMMATIC EFFECT ON MEAN TRANSIT NUMBER OF CHANGE IN BASE ANGLE**

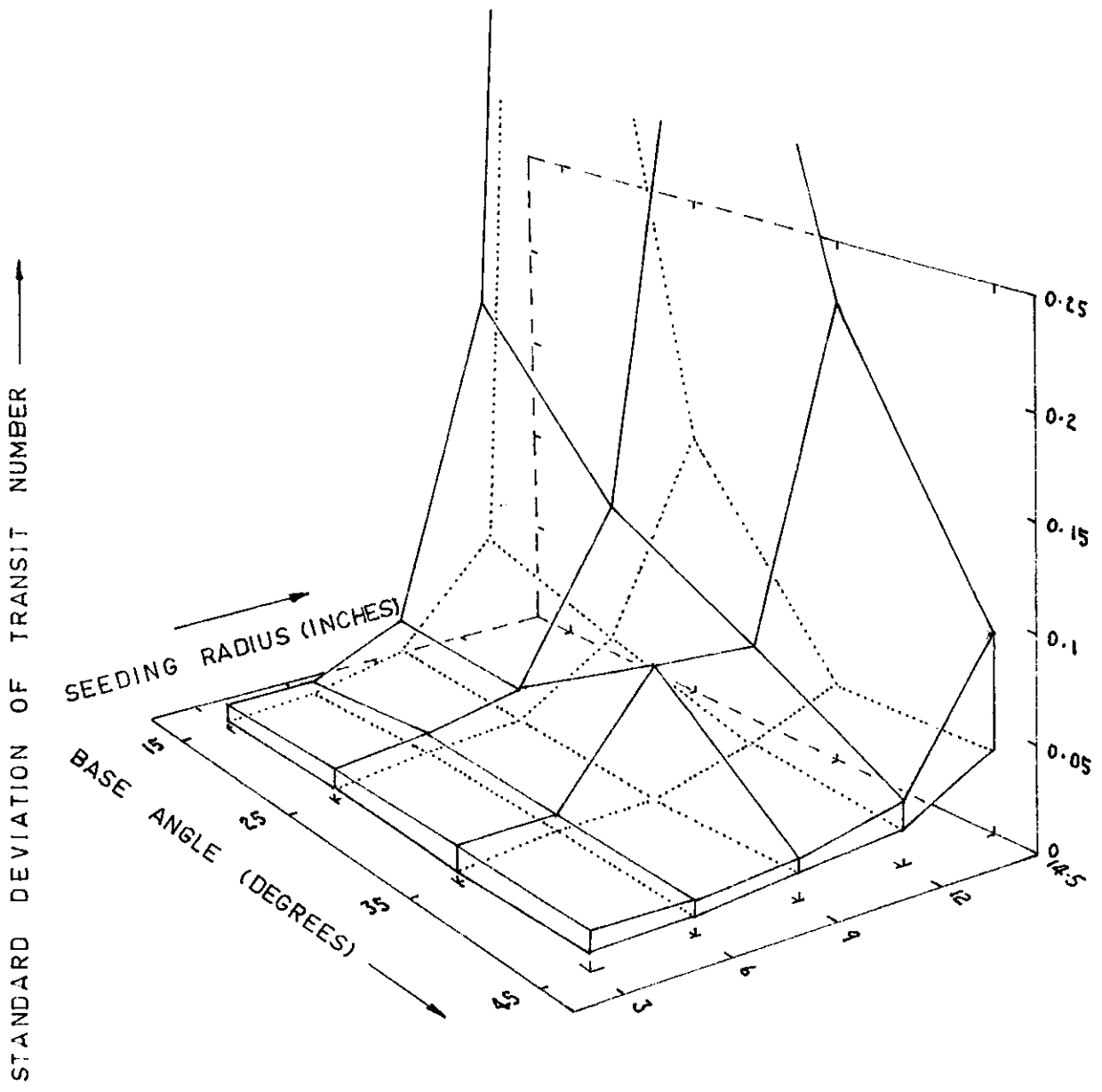

**FIGURE 54. RANGE OF TRANSIT NUMBER SPECTRAL STANDARD DEVIATIONS FOR VARYING BASE ANGLE AND SEEDING RADIUS**

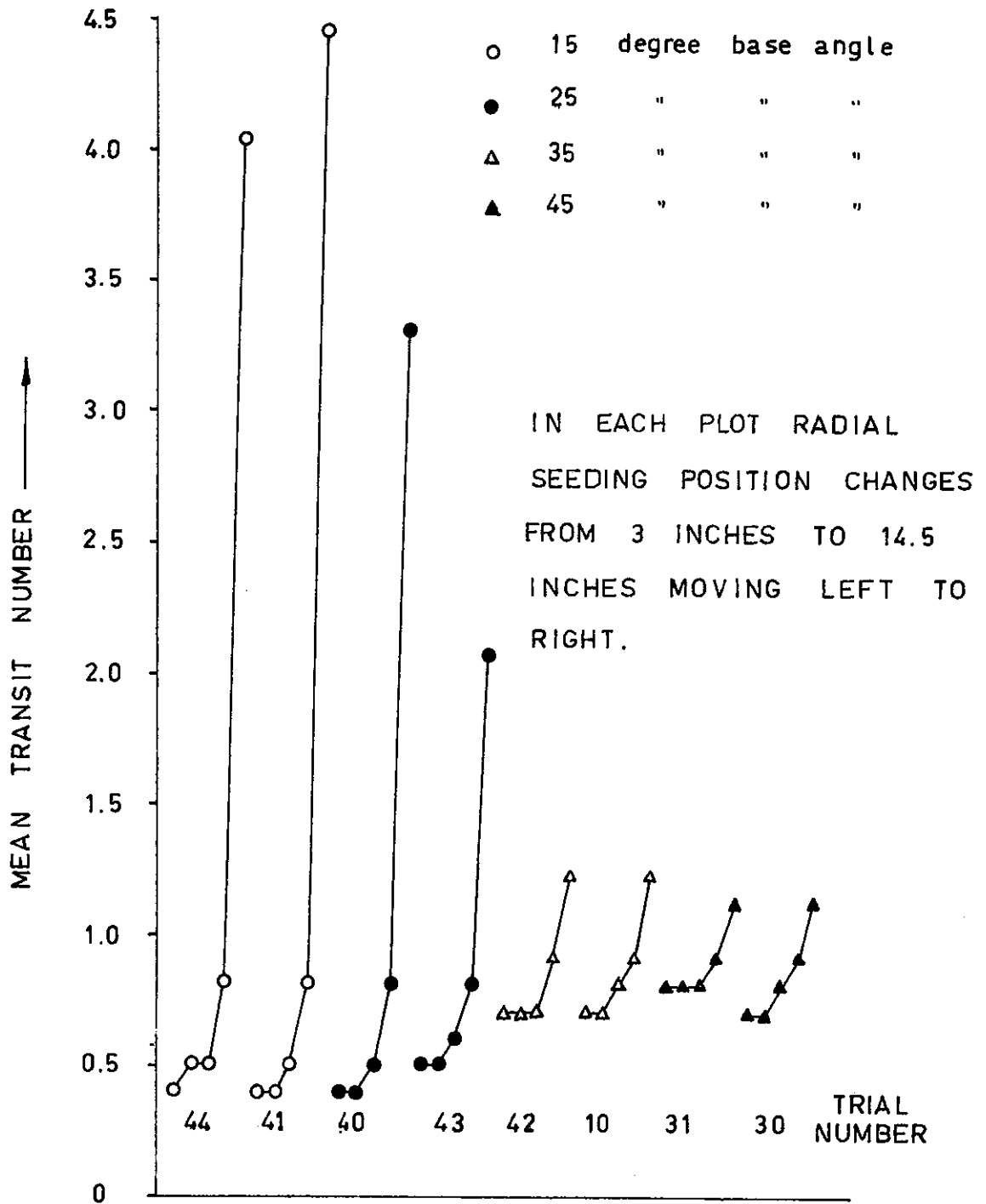

**FIGURE 55. SPECTRAL MEANS AT ALL RADII FOR BASE ANGLE COMPARISON**

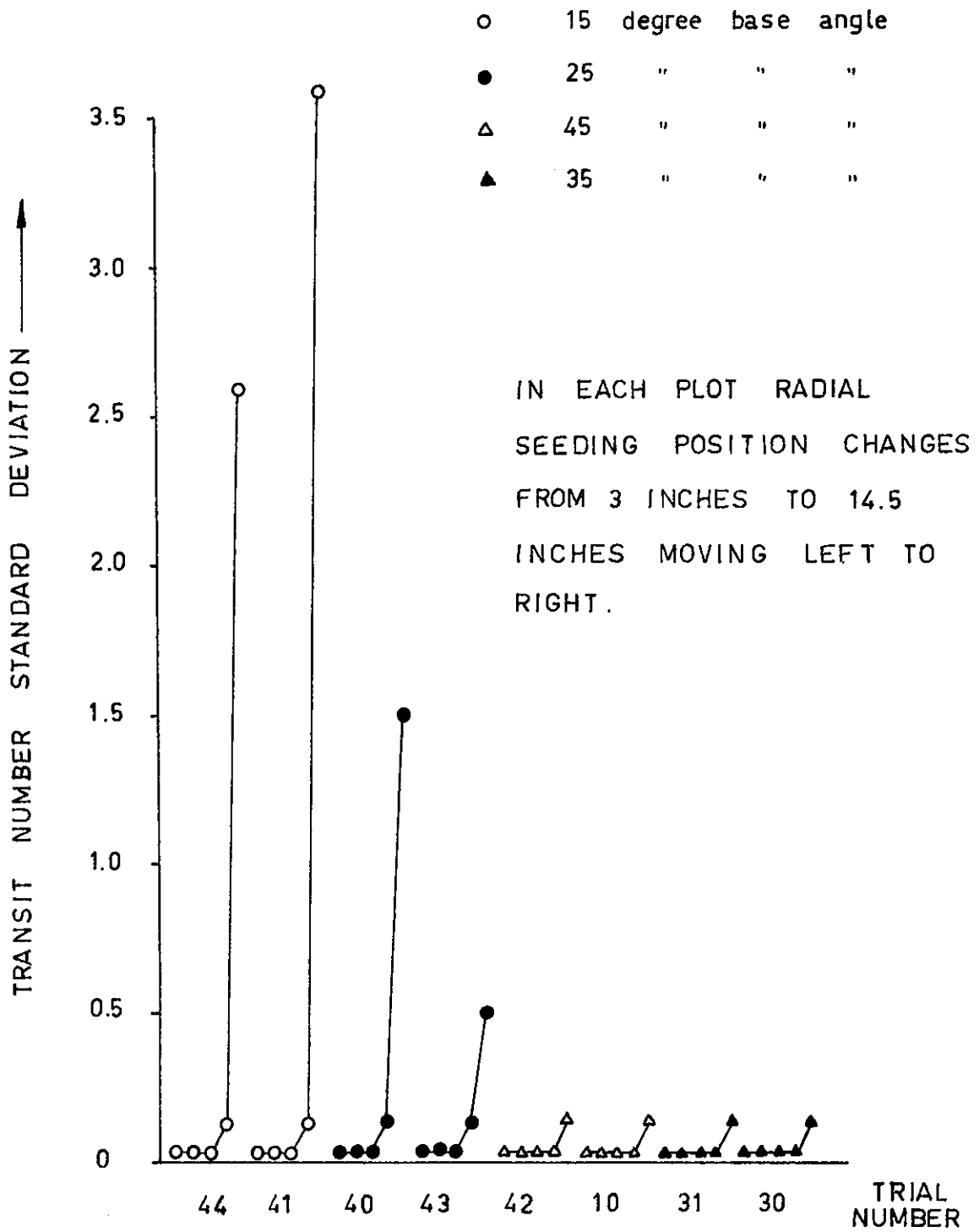

**FIGURE 56. SPECTRAL STANDARD DEVIATIONS AT ALL RADII FOR BASE ANGLE COMPARISON**

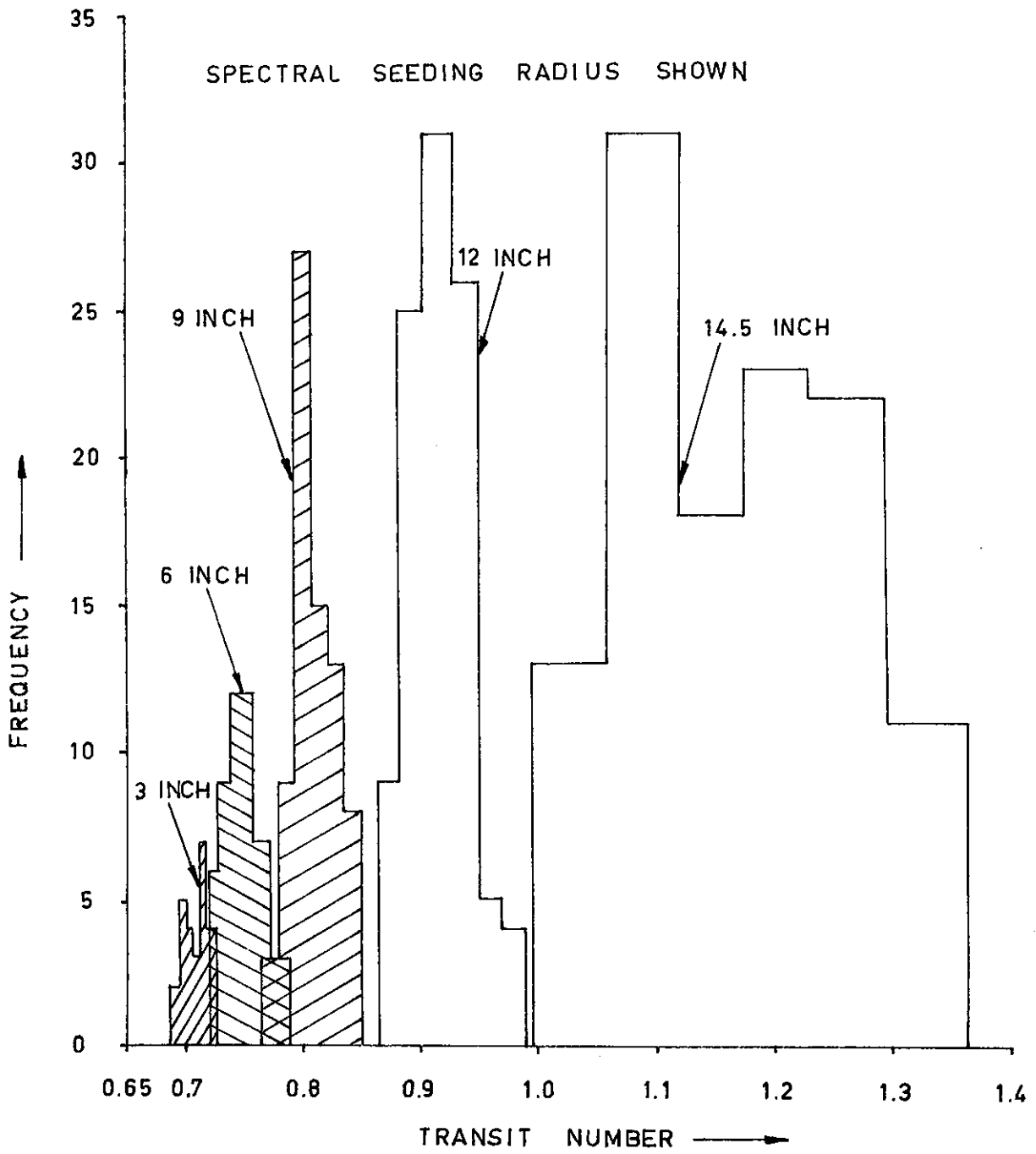

**FIGURE 57. TRANSIT NUMBER SPECTRA FOR TRIAL NUMBER 18  
AT ALL SEEDING RADII**

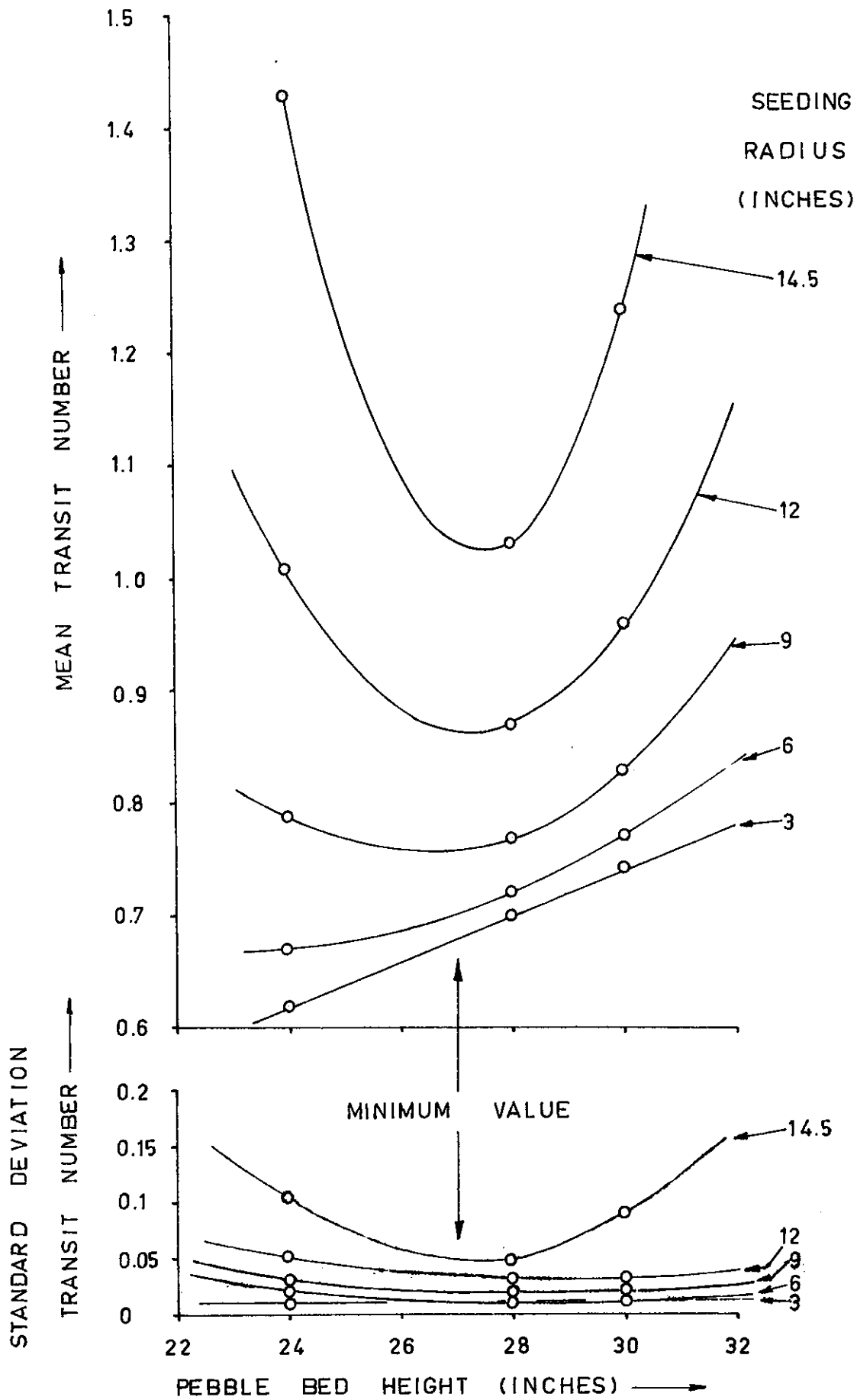

**FIGURE 58. AVERAGE OF MEAN AND STANDARD DEVIATION OF TRANSIT NUMBERS VERSUS PEBBLE BED HEIGHT**